

MF7/MF7D

- Flat type available
- Can be used for wall-mount

Note. When the weight per carrier exceeds 7 kg, special parameters are applicable.

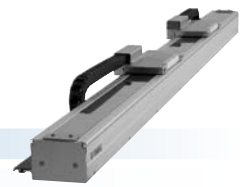

Ordering method

Single carriage model

MF7

Model MF7: Incremental MF7A: Semi-absolute ^{Note 1}	Cable carrier entry location RH: Horizontal, right LH: Horizontal, left FRH: Horizontal, right (Flat) FLH: Horizontal, left (Flat) RW: Wall mount, right LW: Wall mount, left	Optional cable carrier for users^{Note 2} No entry: None S: S type M: M type L: L type	Origin position change Horizontal No entry: L side (Standard) Z: R side No entry: R side (Standard) Z: L side	Grease type No entry: Standard GC: Clean	Stroke^{Note 3} Horizontal 100 to 4000 (100mm pitch) 5L: 5m 10L: 10m 3K/5K/10K (Flexible cable) ^{Note 5} Wall 100 to 2000 (100mm pitch)	Cable length^{Note 4} 3L: 3.5m 5L: 5m 10L: 10m 3K/5K/10K (Flexible cable) ^{Note 5}	TSP Positioner^{Note 6} TS-P	Driver: Power-supply voltage / Power capacity 110: 100V/200W 210: 200V/200W	LCD monitor No entry: None L: With LCD	I/O selection NP: NPN PN: PNP CC: CC-Link DN: DeviceNet™ EP: EtherNet/IP™ GW: No I/O board ^{Note 7}
---	--	---	---	---	--	--	--	--	---	---

SR1-P 10

Controller	Driver: Power capacity 10: 200W	Usable for CE No entry: Standard E: CE marking	I/O selection N: NPN P: PNP CC: CC-Link DN: DeviceNet™ EP: EtherNet/IP™ PB: PROFIBUS
-------------------	---	---	---

RDV-P 2 10 - RBR1

Driver	Power-supply voltage 2: AC200V	Driver: Power capacity 10: 200W or less	Regenerative unit
---------------	--	---	--------------------------

- Note 1. When RDV-P is selected, the semi-absolute specifications cannot be selected.
 Note 2. For models with a 2,100mm or longer stroke, optional L type cable carriers can only be used. Flat type cannot be selected for L type.
 Note 3. Maximum stroke for flat type is 2000mm.
 Note 4. The robot cable is standard cable (3L/5L/10L), but can be changed to flexible cable. See P.692 for details on robot cable.
 Note 5. If a flexible cable is needed for the SR1-P, TS-P, or RDV-P, then select 3K/5K/10K.
 Note 6. These controllers can be mounted on DIN rails. See P.600 for details.
 Note 7. Select this selection when using the gateway function.
 Note. It is possible to provide the model without a cable carrier. To find information on wiring (cable terminals) within the cable carrier see P.703.

Double carriage model

MF7D

Model MF7D: Incremental MF7AD: Semi-absolute ^{Note 1}	Installing direction H: Horizontal installation FH: Horizontal installation (Flat) W: Wall mount installation	Optional cable carrier for users^{Note 2} No entry: None S: S type M: M type L: L type	Grease type No entry: Standard GC: Clean	Stroke^{Note 3} Horizontal 100 to 3800 (100mm pitch) 5L: 5m 10L: 10m 3K/5K/10K (Flexible cable) ^{Note 5} Wall 100 to 1800 (100mm pitch)	Cable length 3L: 3.5m 5L: 5m 10L: 10m 3K/5K/10K (Flexible cable) ^{Note 5}	Controller RCX320 SR1-P (2 units) TS-P (2 units) TS-P (2 units)
---	---	---	---	--	---	--

Note. Specify various controller setting items.

Specifications

Model	MF7	MF7D
Driving method	Steel cored linear motor with falt magnet	
Repeatability (μm)	+/-5	
Scale (μm)	Magnetic type: resolution of 1	
Maximum speed^{Note 2} (mm/sec)	2500	
Rated thrust (N)	37	
Maximum payload (kg)	Horizontal 10 ^{Note 1}	7
Stroke (mm)	Horizontal	100 to 4000 (100mm pitch) / 100 to 3800 (100mm pitch)
	Wall mount	100 to 2000 (100mm pitch) / 100 to 1800 (100mm pitch)
Linear guide	4 rows of circular arc grooves × 1 rail	
Maximum cross-section outside dimensions (mm)	W85 × H80 (except the cable carrier section)	
Total length (mm)	Stroke+280	Stroke+480
Cable length (m)	Standard: 3.5 / Option: 5.10	

Note. A vertical model (with brake) is not available with the PHASER series. Note. The basic specifications of semi-absolute model are the same as those of the incremental model.

Note 1. Payload per carrier. When the weight exceeds 7 kg, special parameters are applicable. Please consult our sales office or sales representative.

Note 2. Table of maximum speed

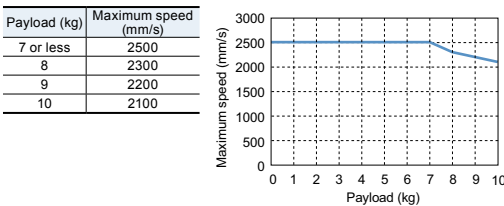

Allowable overhang

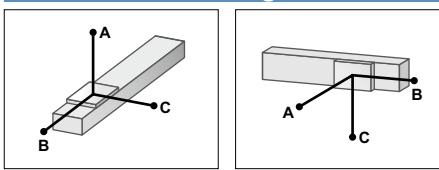

Horizontal installation (Unit: mm)

	A	B	C
1kg	3000	3000	680
3kg	3000	1350	215
5kg	2900	830	125
7kg	2400	580	85
9kg	2200	460	60
10kg	2100	410	55

Wall installation (Unit: mm)

	A	B	C
1kg	700	3000	3000
3kg	195	1260	3000
5kg	90	630	2480
7kg	50	360	1680

Note. Distance from center of slider top to center of gravity of object being carried at a guide service life of 10,000 km.

Static loading moment

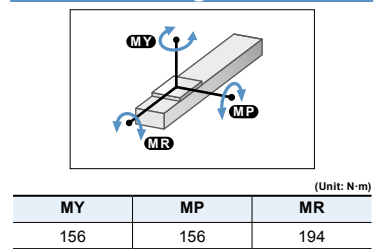

Controller

Controller	Operating method
SR1-P10	Programming / I/O point trace / Remote command / Operation using RS-232C communication
RCX320 RCX340	Operation using RS-232C communication
TS-P110	I/O point trace / Remote command
TS-P210	Remote command
RDV-P210-RBR1	Pulse train control

Cable carrier entry location

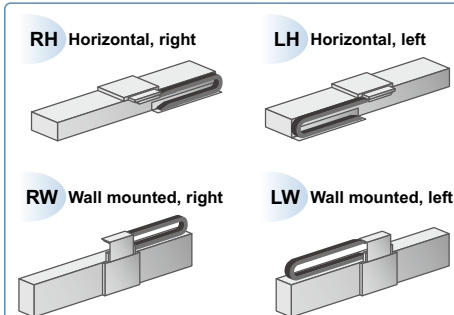

Note. Be sure to install in the direction as specified (in cable carrier take-out direction drawing and various specification drawings) individually. Installation in any other way will cause a failure. For requirement of installation in any way other than the above standard installation, please consult YAMAHA as a special arrangement will be available.

Optional cable carrier for users

S type **M type** **L type**

Cable and air tube guide
 S: φ8 flexible cable x 1, φ4 air tube x 1
 M: φ8 flexible cable x 2, φ6 air tube x 2
 L: φ8 flexible cable x 2, φ6 air tube x 3

□ Space for optional cable for users

MF7 single carriage horizontal mount model **RH**

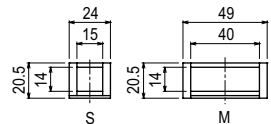
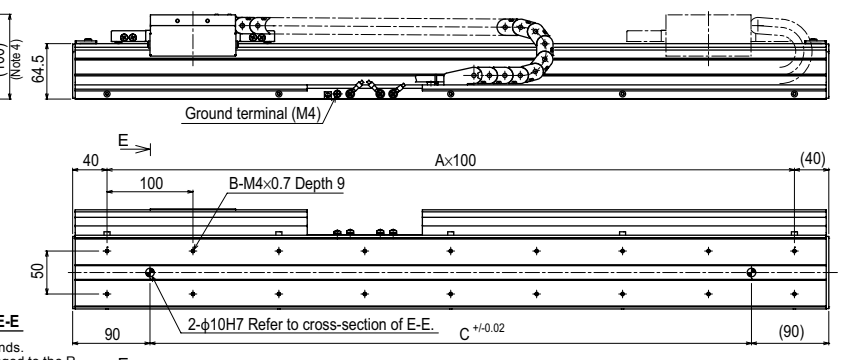
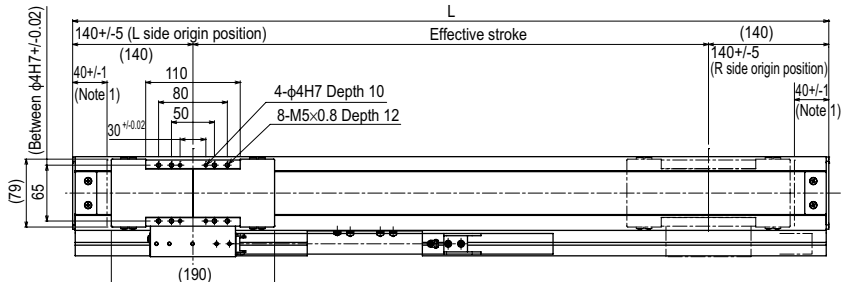
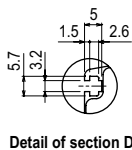
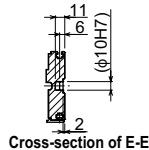
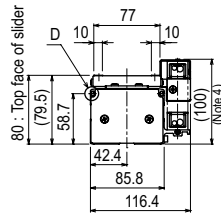
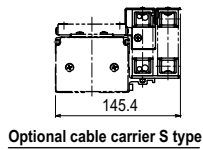
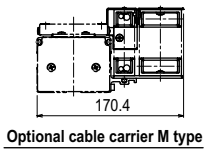

Note 1. Stop positions are determined by the mechanical stoppers at both ends.
 Note 2. The origin is set on the L side at the time of shipment. It can be changed to the R side by parameter setting.
 Note 3. The drawings on this page show the unit with horizontal-right-type cable carrier (RH).
 Note 4. Depending on the stroke and the operating conditions, the cable carrier bending radius might be larger, making it higher than the dimensions shown in the diagram.

Effective stroke	100	200	300	400	500	600	700	800	900	1000	1100	1200	1300	1400	1500	1600	1700	1800	1900	2000
L	380	480	580	680	780	880	980	1080	1180	1280	1380	1480	1580	1680	1780	1880	1980	2080	2180	2280
A	3	4	5	6	7	8	9	10	11	12	13	14	15	16	17	18	19	20	21	22
B	8	10	12	14	16	18	20	22	24	26	28	30	32	34	36	38	40	42	44	46
C	200	300	400	500	600	700	800	900	1000	1100	1200	1300	1400	1500	1600	1700	1800	1900	2000	2100
Weight (kg)	5.8	6.5	7.3	8	8.7	9.4	10.1	10.9	11.6	12.3	13	13.7	14.5	15.2	15.9	16.6	17.3	18.1	18.8	19.5

MF7 single carriage wall mount model **RW**

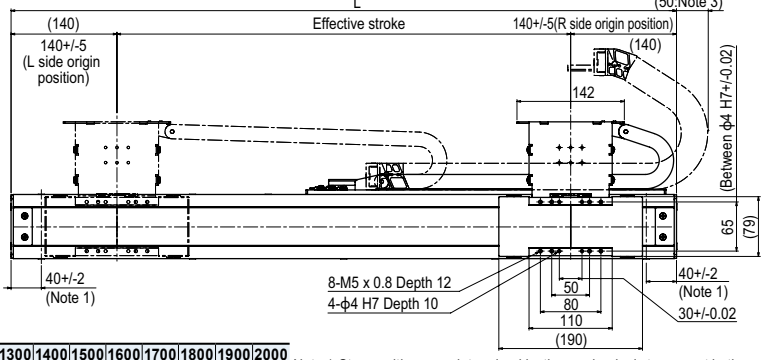
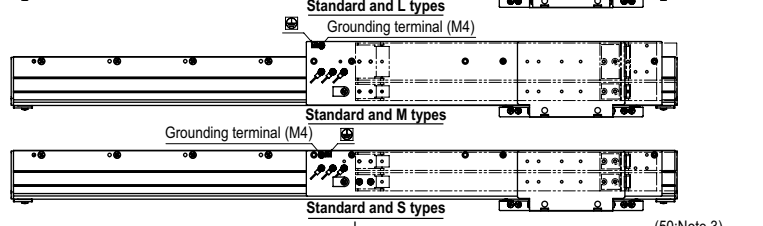
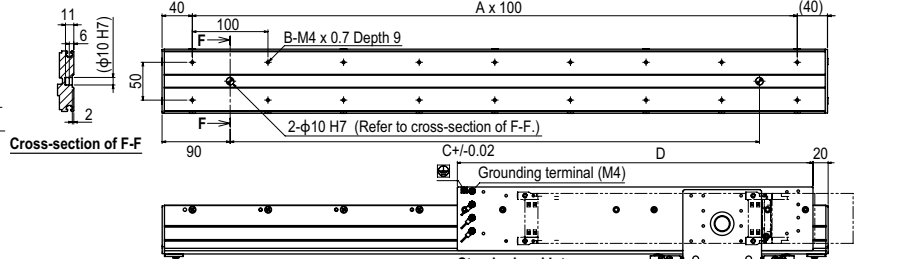
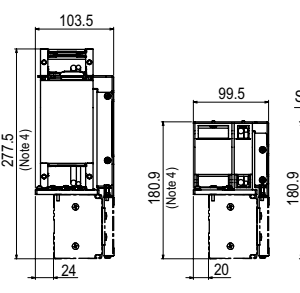
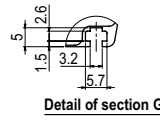
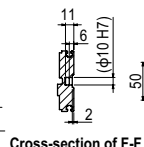
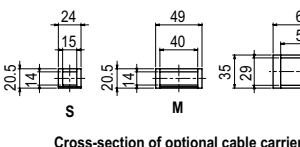

Effective stroke	100	200	300	400	500	600	700	800	900	1000	1100	1200	1300	1400	1500	1600	1700	1800	1900	2000
L	380	480	580	680	780	880	980	1080	1180	1280	1380	1480	1580	1680	1780	1880	1980	2080	2180	2280
A	3	4	5	6	7	8	9	10	11	12	13	14	15	16	17	18	19	20	21	22
B	8	10	12	14	16	18	20	22	24	26	28	30	32	34	36	38	40	42	44	46
C	200	300	400	500	600	700	800	900	1000	1100	1200	1300	1400	1500	1600	1700	1800	1900	2000	2100
D	220	270	320	370	420	470	520	570	620	670	720	770	820	870	920	970	1020	1070	1120	1170
Weight (kg)	5.8	6.5	7.3	8	8.7	9.4	10.1	10.9	11.6	12.3	13	13.7	14.5	15.2	15.9	16.6	17.3	18.1	18.8	19.5

Note 1. Stop positions are determined by the mechanical stoppers at both ends.
 Note 2. The origin is set on the R side at the time of shipment. It can be changed to the L side by parameter setting.
 Note 3. Cable carrier's protrusion amount from the mechanical end (For "L" specs.).
 Note 4. Depending on the stroke and the operating conditions, the cable carrier bending radius might be larger, making it higher than the dimensions shown in the diagram.

MF7 single carriage horizontal mount model **RH-L** Optional L-type cable carrier

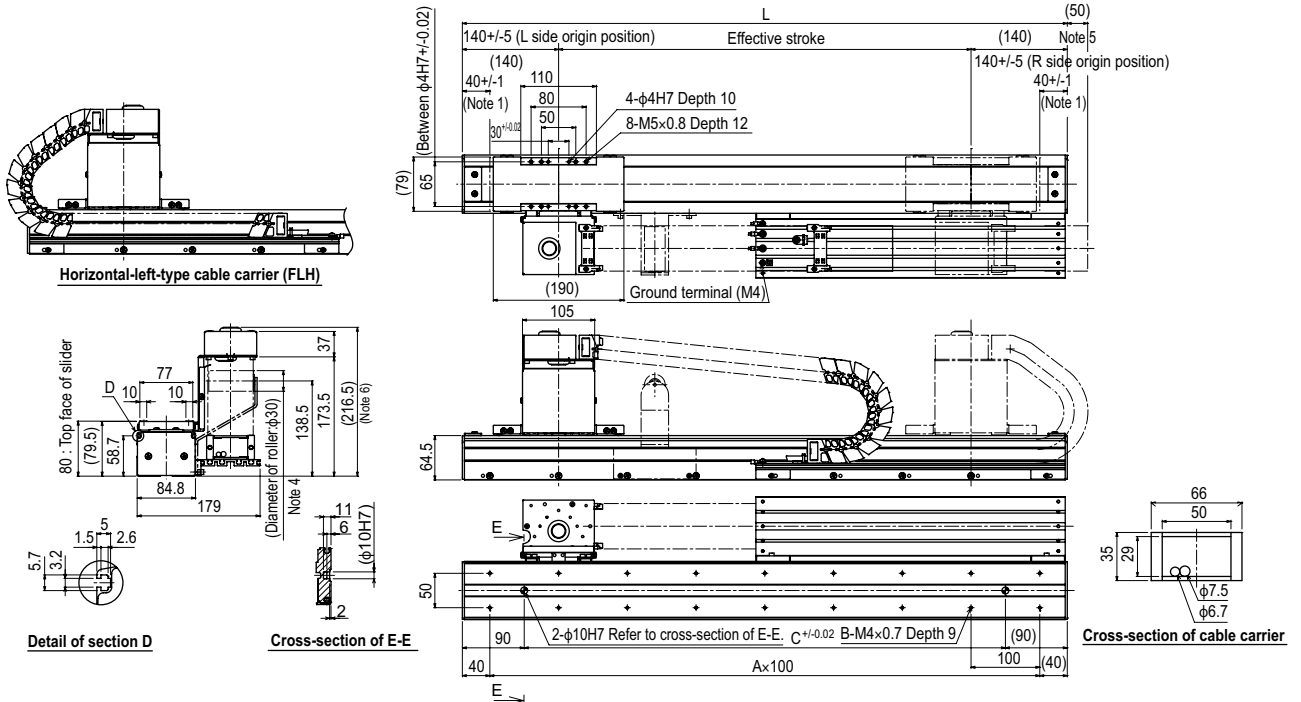

Note 1. Stop positions are determined by the mechanical stoppers at both ends.
 Note 2. The origin is set on the L side at the time of shipment. It can be changed to the R side by parameter setting.
 Note 3. The drawings on this page show the unit with horizontal-right-type cable carrier (RH).
 Note 4. For models with a 3,000mm or longer stroke, a roller is installed to prevent the cable carrier from sagging.
 Note 5. Protrusion is the distance the cable carrier extends from the edge of the unit.
 Note 6. Depending on the stroke and the operating conditions, the cable carrier bending radius might be larger, making it higher than the dimensions shown in the diagram.

Effective stroke	100	200	300	400	500	600	700	800	900	1000	1100	1200	1300	1400	1500	1600	1700	1800	1900	2000	2100	2200	2300	2400	2500	2600	2700	2800	2900	3000	3100	3200	3300	3400	3500	3600	3700	3800	3900	4000
L	380	480	580	680	780	880	980	1080	1180	1280	1380	1480	1580	1680	1780	1880	1980	2080	2180	2280	2380	2480	2580	2680	2780	2880	2980	3080	3180	3280	3380	3480	3580	3680	3780	3880	3980	4080	4180	4280
A	3	4	5	6	7	8	9	10	11	12	13	14	15	16	17	18	19	20	21	22	23	24	25	26	27	28	29	30	31	32	33	34	35	36	37	38	39	40	41	42
B	8	10	12	14	16	18	20	22	24	26	28	30	32	34	36	38	40	42	44	46	48	50	52	54	56	58	60	62	64	66	68	70	72	74	76	78	80	82	84	86
C	200	300	400	500	600	700	800	900	1000	1100	1200	1300	1400	1500	1600	1700	1800	1900	2000	2100	2200	2300	2400	2500	2600	2700	2800	2900	3000	3100	3200	3300	3400	3500	3600	3700	3800	3900	4000	4100
Weight (kg)	5.8	6.5	7.3	8.0	8.7	9.4	10.1	10.9	11.6	12.3	13.0	13.7	14.5	15.2	15.9	16.6	17.3	18.1	18.8	19.5	20.2	20.9	21.7	22.4	23.1	23.8	24.5	25.3	26.0	26.7	27.4	28.1	28.9	29.6	30.3	31.0	31.7	32.5	33.2	33.9

MF7 single carriage horizontal mount model **FRH** Flat type

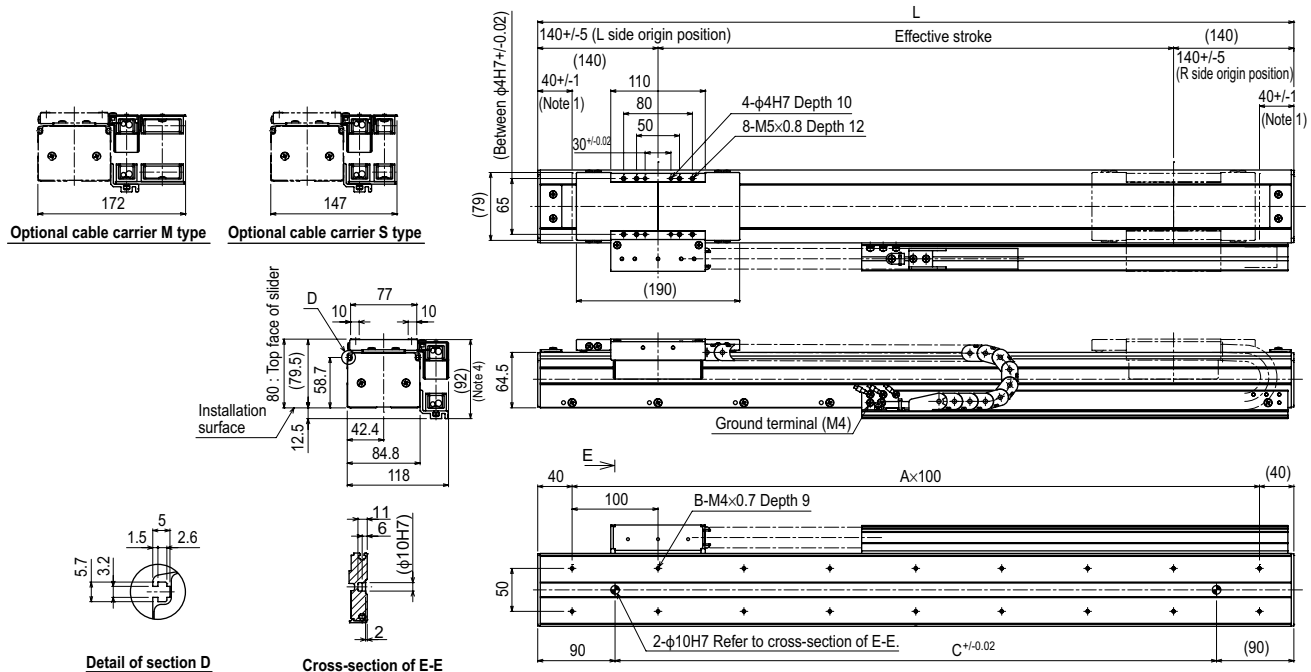

Note 1. Stop positions are determined by the mechanical stoppers at both ends.
 Note 2. The origin is set on the L side at the time of shipment. It can be changed to the R side by parameter setting.
 Note 3. The drawings on this page show the unit with horizontal-right-type cable carrier (RH).
 Note 4. Depending on the stroke and the operating conditions, the cable carrier bending radius might be larger, making it higher than the dimensions shown in the diagram.

Effective stroke	100	200	300	400	500	600	700	800	900	1000	1100	1200	1300	1400	1500	1600	1700	1800	1900	2000
L	380	480	580	680	780	880	980	1080	1180	1280	1380	1480	1580	1680	1780	1880	1980	2080	2180	2280
A	3	4	5	6	7	8	9	10	11	12	13	14	15	16	17	18	19	20	21	22
B	8	10	12	14	16	18	20	22	24	26	28	30	32	34	36	38	40	42	44	46
C	200	300	400	500	600	700	800	900	1000	1100	1200	1300	1400	1500	1600	1700	1800	1900	2000	2100
Weight (kg)	5.8	6.5	7.3	8	8.7	9.4	10.1	10.9	11.6	12.3	13	13.7	14.5	15.2	15.9	16.6	17.3	18.1	18.8	19.5

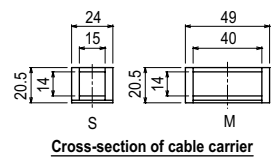

MF7D double carriage horizontal mount model **H**

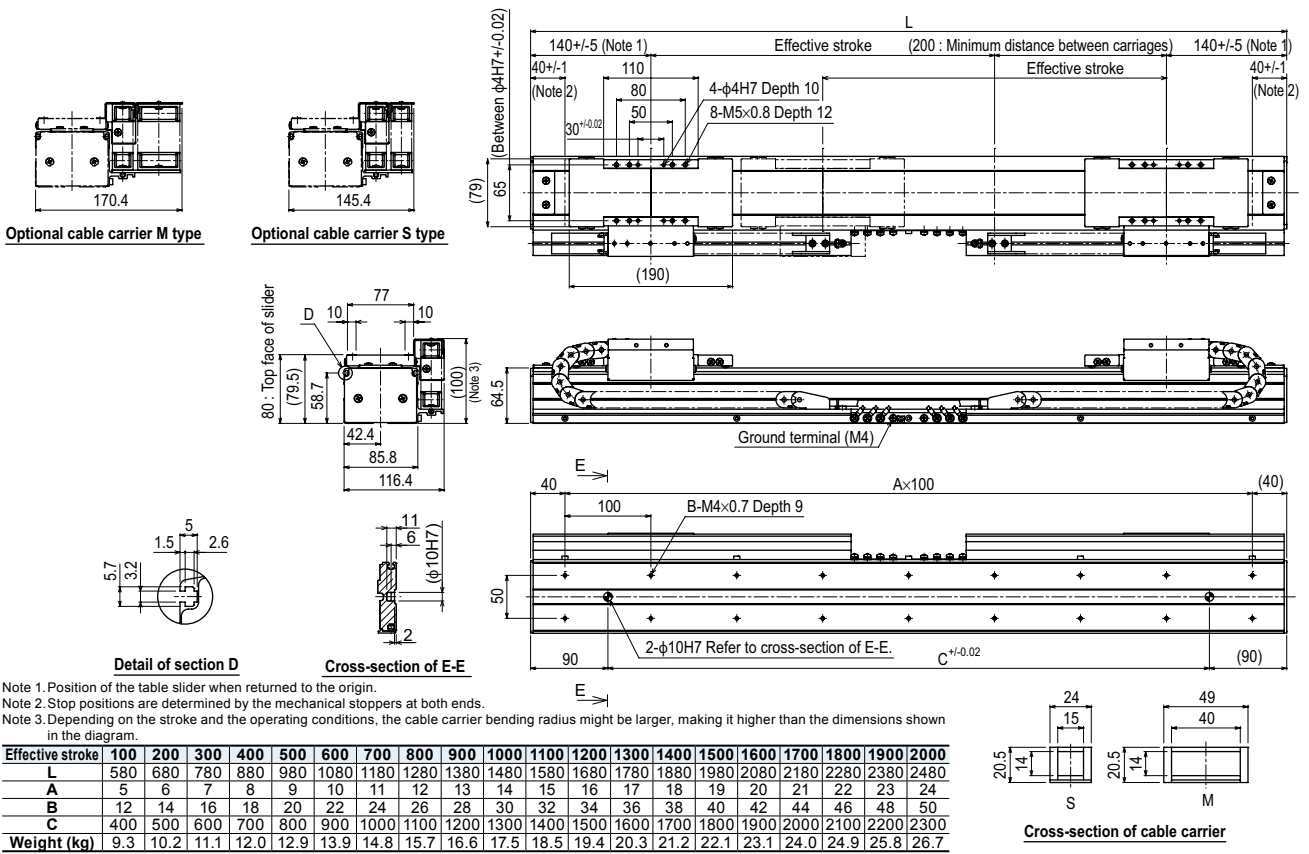

MF7D double carriage wall mount model **W**

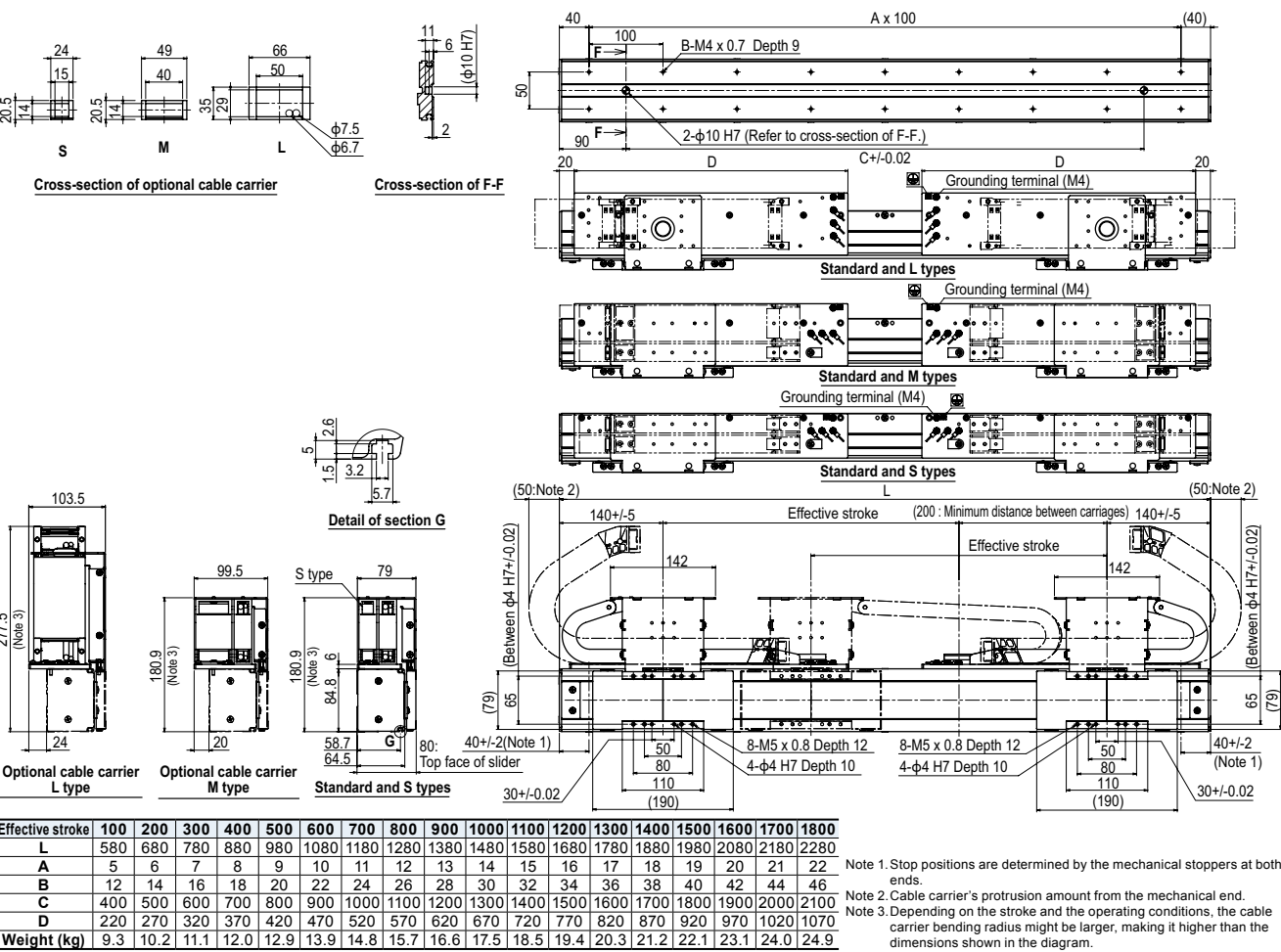

Linear conveyor modules
 LCMR200
 Single-axis robots
 GX
 Linear conveyor modules
 LCM100
 SCARA robots
 YK-X
 Single-axis robots
 Robomity
 Linear motor single-axis robots
 PHASER
 Single-axis robots
 FLIP-X
 Compact single-axis robots
 TRANSERO
 Cartesian robots
 XX-X
 Pick & place robots
 YP-X
 CLEAN
 CONTROLLER INFORMATION

MF7D double carriage horizontal mount model **H-L** Optional L-type cable carrier

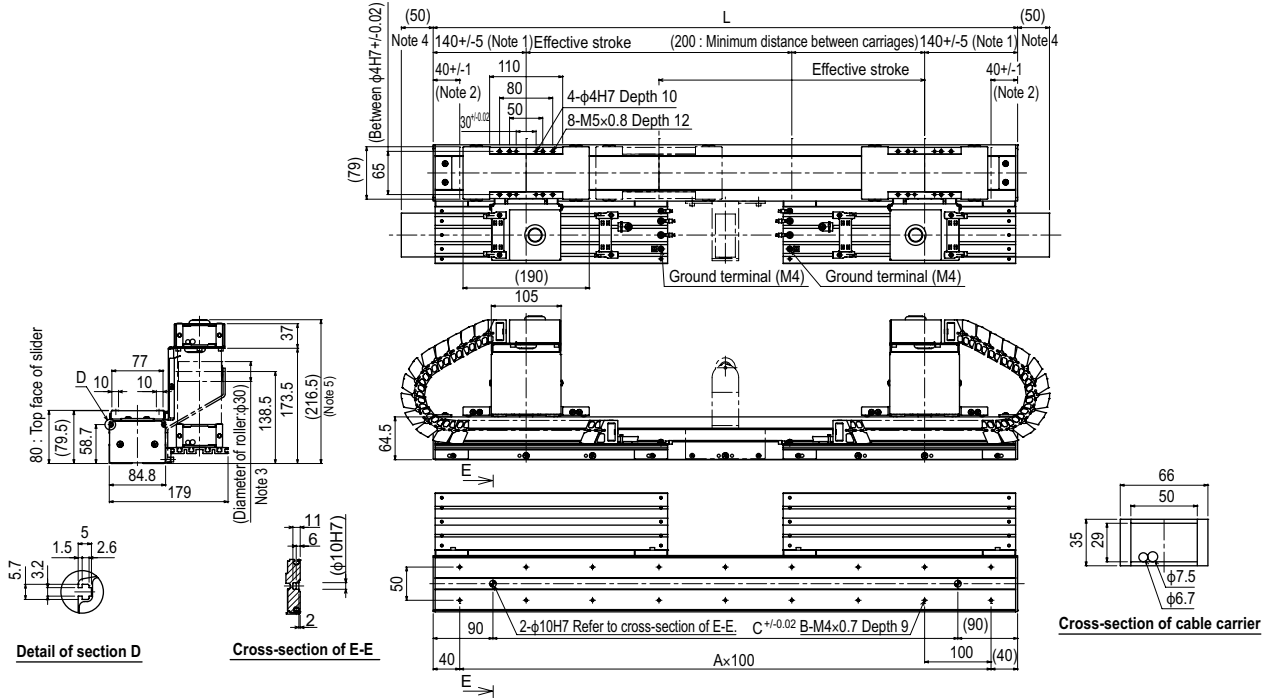

Note 1. Position of the table slider when returned to the origin.
 Note 2. Stop positions are determined by the mechanical stoppers at both ends.
 Note 3. For models with a 3,000mm or longer stroke, a roller is installed to prevent the cable carrier from sagging.
 Note 4. Protrusion is the distance the cable carrier extends from the edge of the unit.
 Note 5. Depending on the stroke and the operating conditions, the cable carrier bending radius might be larger, making it higher than the dimensions shown in the diagram.

Effective stroke	100	200	300	400	500	600	700	800	900	1000	1100	1200	1300	1400	1500	1600	1700	1800	1900	2000	2100	2200	2300	2400	2500	2600	2700	2800	2900	3000	3100	3200	3300	3400	3500	3600	3700	3800
L	580	680	780	880	980	1080	1180	1280	1380	1480	1580	1680	1780	1880	1980	2080	2180	2280	2380	2480	2580	2680	2780	2880	2980	3080	3180	3280	3380	3480	3580	3680	3780	3880	3980	4080	4180	4280
A	5	6	7	8	9	10	11	12	13	14	15	16	17	18	19	20	21	22	23	24	25	26	27	28	29	30	31	32	33	34	35	36	37	38	39	40	41	42
B	12	14	16	18	20	22	24	26	28	30	32	34	36	38	40	42	44	46	48	50	52	54	56	58	60	62	64	66	68	70	72	74	76	78	80	82	84	86
C	400	500	600	700	800	900	1000	1100	1200	1300	1400	1500	1600	1700	1800	1900	2000	2100	2200	2300	2400	2500	2600	2700	2800	2900	3000	3100	3200	3300	3400	3500	3600	3700	3800	3900	4000	4100
Weight (kg)	9.3	10.2	11.1	12.0	12.9	13.9	14.8	15.7	16.6	17.5	18.5	19.4	20.3	21.2	22.1	23.1	24.0	24.9	25.8	26.7	27.7	28.6	29.5	30.4	31.3	32.3	33.2	34.1	35.0	35.9	36.9	37.8	38.7	39.6	40.5	41.5	42.4	43.3

MF7D double carriage horizontal mount model **FH** Flat type

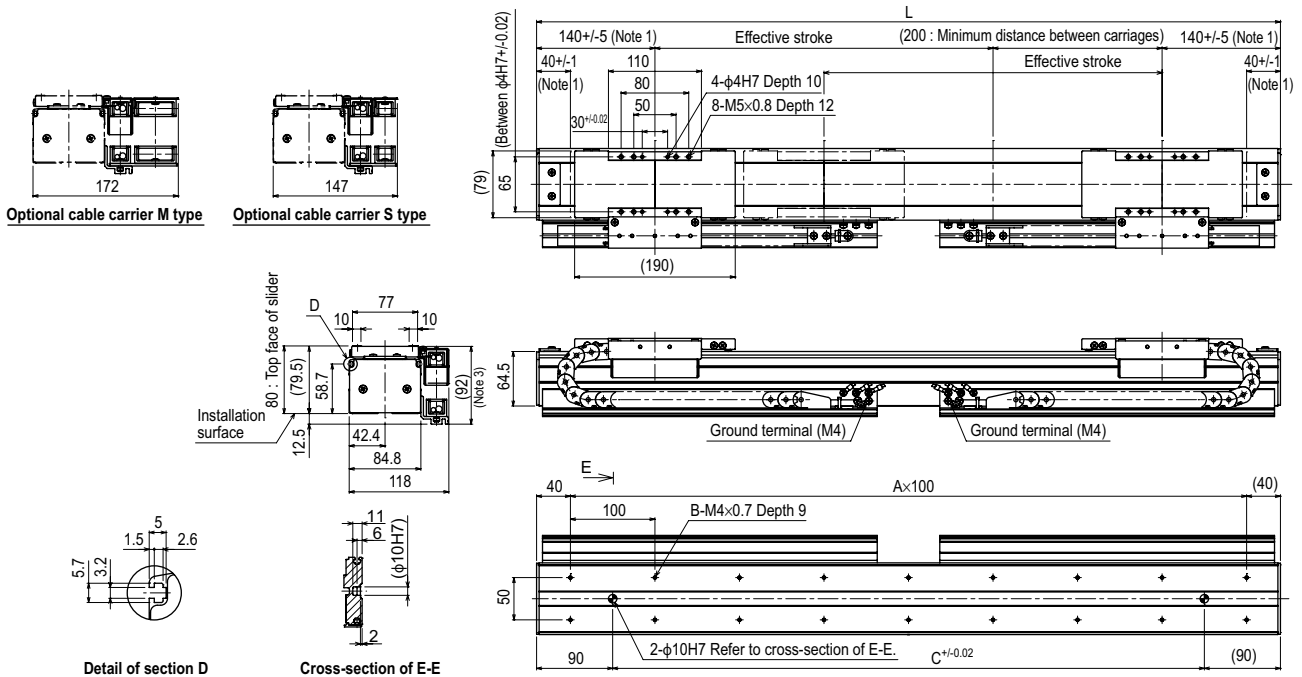

Note 1. Position of the table slider when returned to the origin.
 Note 2. Stop positions are determined by the mechanical stoppers at both ends.
 Note 3. Depending on the stroke and the operating conditions, the cable carrier bending radius might be larger, making it higher than the dimensions shown in the diagram.

Effective stroke	100	200	300	400	500	600	700	800	900	1000	1100	1200	1300	1400	1500	1600	1700	1800	1900	2000
L	580	680	780	880	980	1080	1180	1280	1380	1480	1580	1680	1780	1880	1980	2080	2180	2280	2380	2480
A	5	6	7	8	9	10	11	12	13	14	15	16	17	18	19	20	21	22	23	24
B	12	14	16	18	20	22	24	26	28	30	32	34	36	38	40	42	44	46	48	50
C	400	500	600	700	800	900	1000	1100	1200	1300	1400	1500	1600	1700	1800	1900	2000	2100	2200	2300
Weight (kg)	9.3	10.2	11.1	12.0	12.9	13.9	14.8	15.7	16.6	17.5	18.5	19.4	20.3	21.2	22.1	23.1	24.0	24.9	25.8	26.7

Linear conveyor
modules
LCMR200

Single-axis robots
GX

Linear conveyor
modules
LCM100

SCARA robots
YK-X

Single-axis robots
Robonity

Linear motor
single-axis robots
PHASER

Single-axis robots
FLIP-X

Compact
single-axis robots
TRANSERVO

Cartesian robots
XY-X

Pick & place
robots
YP-X

CLEAN

CONTROLLER

INFORMATION

MF15/MF15D

Can be used for wall-mount

Note. When the weight per carrier exceeds 15 kg, special parameters are applicable.



Ordering method

Single carriage model

MF15

Model MF15: Incremental MF15A: Semi-absolute ^{Note 1}	Cable carrier entry location RH: Horizontal, right LH: Horizontal, left RW: Wall mount, right LW: Wall mount, left	Optional cable carrier for users^{Note 2} No entry: None S: S type M: M type L: L type	Origin position change Horizontal: No entry: L side (Standard) Z: R side Wall: No entry: R side (Standard) Z: L side	Grease type No entry: Standard GC: Clean	Stroke Horizontal: 100 to 4000 (100mm pitch) Wall: 100 to 2000 (100mm pitch)	Cable length^{Note 3} 3L: 3.5m 5L: 5m 10L: 10m 3K/5K/10K (Flexible cable) ^{Note 4}	TSP Positioner^{Note 5} TS-P	Driver: Power-supply voltage / Power capacity 110: 100V/200W 210: 200V/200W	LCD monitor No entry: None L: With LCD	I/O selection NP: NPN PN: PNP CC: CC-Link DN: DeviceNet™ EP: EtherNet/IP™ GW: No I/O board ^{Note 6}
---	---	---	---	---	---	--	--	--	---	---

SR1-P	10	Controller	Driver: Power capacity 10: 200W	Usable for CE No entry: Standard E: CE marking	I/O selection N: NPN P: PNP CC: CC-Link DN: DeviceNet™ EP: EtherNet/IP™ PB: PROFIBUS
--------------	-----------	-------------------	---	---	---

RDV-P	2	10	RBR1
Driver	Power-supply voltage Z: AC200V	Driver: Power capacity 10: 200W or less	Regenerative unit

Note 1. When RDV-P is selected, the semi-absolute specifications cannot be selected.
 Note 2. For models with a 2,100mm or longer stroke, optional L type cable carriers can only be used.
 Note 3. The robot cable is standard cable (3L/5L/10L), but can be changed to flexible cable. See P.692 for details on robot cable.
 Note 4. If a flexible cable is needed for the SR1-P, TS-P, or RDV-P, then select 3K/5K/10K.
 Note 5. These controllers can be mounted on DIN rails. See P.600 for details.
 Note 6. Select this selection when using the gateway function.
 Note. It is possible to provide the model without a cable carrier. To find information on wiring (cable terminals) within the cable carrier see P.703.

Double carriage model

MF15D

Model MF15D: Incremental MF15AD: Semi-absolute ^{Note 1}	Installing direction H: Horizontal installation W: Wall mount installation	Optional cable carrier for users^{Note 2} No entry: None S: S type M: M type L: L type	Grease type No entry: Standard GC: Clean	Stroke Horizontal: 100 to 3800 (100mm pitch) Wall: 100 to 1800 (100mm pitch)	Cable length 3L: 3.5m 5L: 5m 10L: 10m 3K/5K/10K (Flexible cable) ^{Note 4}	Controller RCX320 SR1-P (2 units) TS-P (2 units) RDV-P (2 units)
---	---	---	---	---	---	---

Note. Specify various controller setting items.

Specifications

Model	MF15	MF15D
Driving method	Steel cored linear motor with falt magnet	
Repeatability (µm)	+/-5	
Scale (µm)	Magnetic type: resolution of 1	
Maximum speed^{Note 2} (mm/sec)	2500	
Rated thrust (N)	54	
Maximum payload^{Note 1} (kg)	30	
Stroke (mm)	Horizontal	100 to 4000 (100mm pitch) / 100 to 3800 (100mm pitch)
	Wall mount	100 to 2000 (100mm pitch) / 100 to 1800 (100mm pitch)
Linear guide	4 rows of circular arc grooves x 2 rail	
Maximum cross-section outside dimensions (mm)	W100 x H80 (except the cable carrier section)	
Total length (mm)	Stroke+260	Stroke+460
Cable length (m)	Standard: 3.5 / Option: 5,10	

Note. A vertical model (with brake) is not available with the PHASER series.
 Note. The basic specifications of semi-absolute model are the same as those of the incremental model.

Note 1. Payload per carrier. When the weight exceeds 15 kg, special parameters are applicable. Please consult our sales office or sales representative.

Note 2. Table of maximum speed

Payload (kg)	Maximum speed (mm/s)
15 or less	2500
20	2200
25	1800
30	1500

Allowable overhang

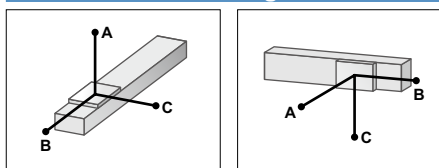

Horizontal installation (Unit: mm)

	A	B	C
5kg	3000	3000	915
10kg	2604	1542	481
15kg	2368	1051	340
20kg	1820	600	260
25kg	1470	450	175
30kg	1250	310	145

Wall installation (Unit: mm)

	A	B	C
5kg	865	1880	3060
10kg	410	905	2115
15kg	255	575	1910
20kg	170	410	1780
25kg	120	295	1660
30kg	90	215	1440

Note. Distance from center of slider top to center of gravity of object being carried at a guide service life of 10,000 km.

Static loading moment

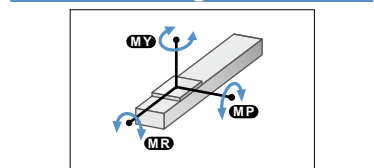

	MY	MP	MR
(Unit: N·m)	290	291	256

Controller

Controller	Operating method
SR1-P10	Programming / I/O point trace / Remote command / Operation using RS-232C communication
RCX320 RCX340	Operation using RS-232C communication
TS-P110	I/O point trace / Remote command
TS-P210	Remote command
RDV-P210-RBR1	Pulse train control

Cable carrier entry location

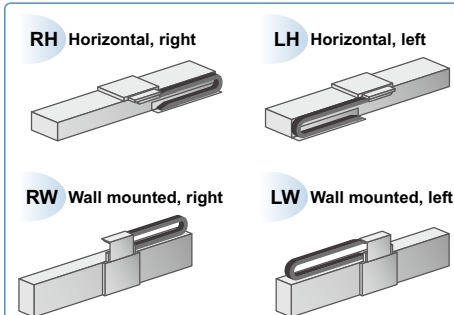

Note. Be sure to install in the direction as specified (in cable carrier take-out direction drawing and various specification drawings) individually. Installation in any other way will cause a failure. For requirement of installation in any way other than the above standard installation, please consult YAMAHA as special arrangement will be available.

Optional cable carrier for users

Cable and air tube guide

S: φ8 flexible cable x 1, φ4 air tube x 1
 M: φ8 flexible cable x 2, φ6 air tube x 2
 L: φ8 flexible cable x 2, φ6 air tube x 3

Space for optional cable for users

MF15 single carriage wall mount model RW

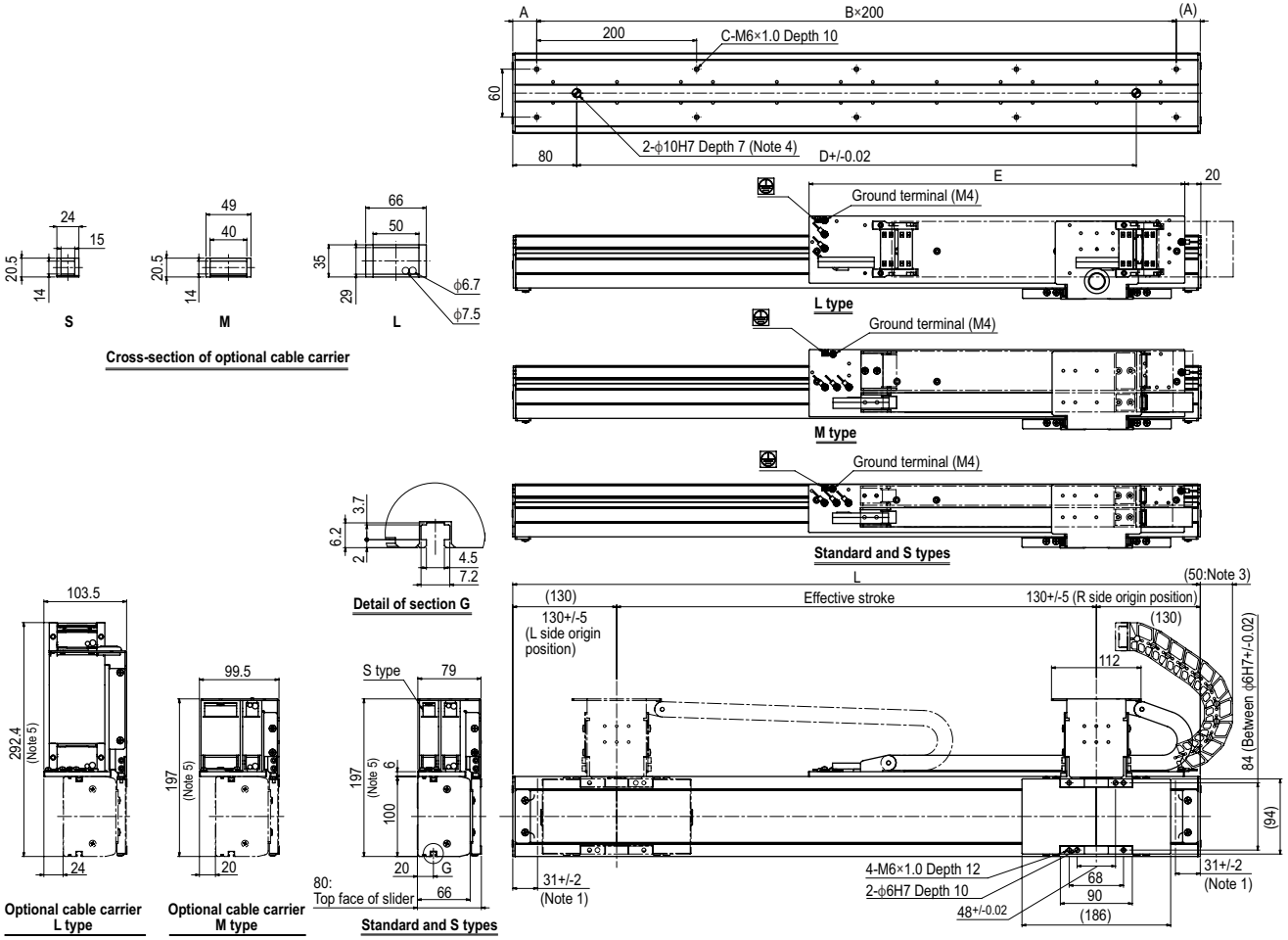

Note 1. Stop positions are determined by the mechanical stoppers at both ends.
 Note 2. The origin is set on the R side at the time of shipment. It can be changed to the L side by parameter setting.
 Note 3. Protrusion is the distance the cable carrier extends from the edge of unit when an optional L type cable carrier is used.
 Note 4. When using φ10 H7 hole, do not insert the pin more than the depth stated in the drawing. Otherwise, the motor may break.
 Note 5. Depending on the stroke and the operating conditions, the cable carrier bending radius might be larger, making it higher than the dimensions shown in the diagram.

Effective stroke	100	200	300	400	500	600	700	800	900	1000	1100	1200	1300	1400	1500	1600	1700	1800	1900	2000
L	360	460	560	660	760	860	960	1060	1160	1260	1360	1460	1560	1660	1760	1860	1960	2060	2160	2260
A	80	30	80	30	80	30	80	30	80	30	80	30	80	30	80	30	80	30	80	30
B	1	2	2	3	3	4	4	5	5	6	6	7	7	8	8	9	9	10	10	11
C	4	6	6	8	8	10	10	12	12	14	14	16	16	18	18	20	20	22	22	24
D	200	300	400	500	600	700	800	900	1000	1100	1200	1300	1400	1500	1600	1700	1800	1900	2000	2100
E	220	270	320	370	420	470	520	570	620	670	720	770	820	870	920	970	1020	1070	1120	1170
Weight (kg)	6.3	7.3	8.3	9.3	10.3	11.3	12.3	13.3	14.3	15.4	16.4	17.4	18.4	19.4	20.4	21.4	22.4	23.4	24.4	25.4

MF15D double carriage wall mount model

W

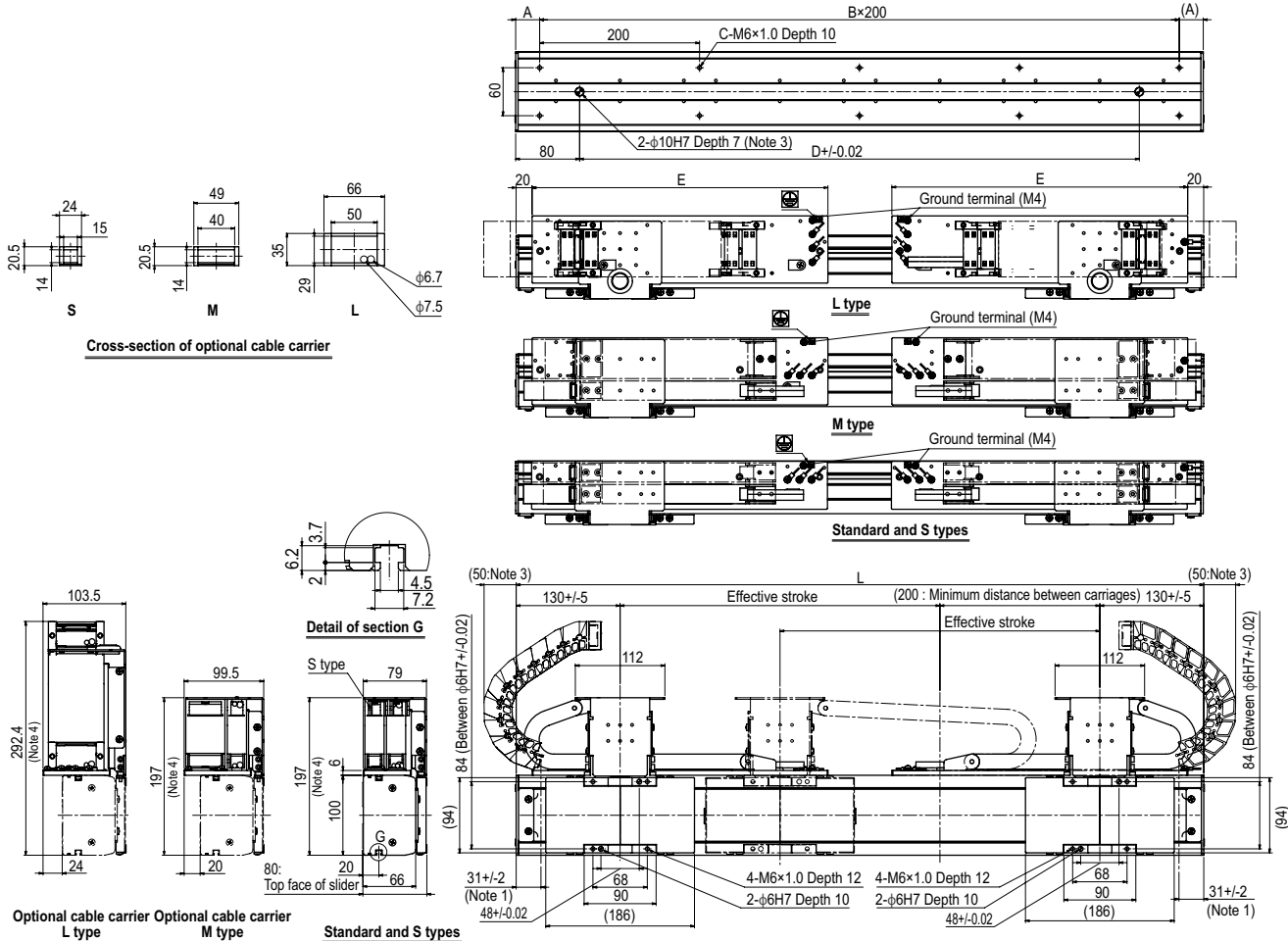

Note 1. Stop positions are determined by the mechanical stoppers at both ends.
 Note 2. Protrusion is the distance the cable carrier extends from the edge of unit when an optional L type cable carrier is used.
 Note 3. When using φ10 H7 hole, do not insert the pin more than the depth stated in the drawing. Otherwise, the motor may break.
 Note 4. Depending on the stroke and the operating conditions, the cable carrier bending radius might be larger, making it higher than the dimensions shown in the diagram.

Effective stroke	100	200	300	400	500	600	700	800	900	1000	1100	1200	1300	1400	1500	1600	1700	1800
L	560	660	760	860	960	1060	1160	1260	1360	1460	1560	1660	1760	1860	1960	2060	2160	2260
A	80	30	80	30	80	30	80	30	80	30	80	30	80	30	80	30	80	30
B	2	3	3	4	4	5	5	6	6	7	7	8	8	9	9	10	10	11
C	6	8	8	10	10	12	12	14	14	16	16	18	18	20	20	22	22	24
D	400	500	600	700	800	900	1000	1100	1200	1300	1400	1500	1600	1700	1800	1900	2000	2100
E	220	270	320	370	420	470	520	570	620	670	720	770	820	870	920	970	1020	1070
Weight (kg)	10.3	11.5	12.6	13.7	14.8	16.0	17.1	18.2	19.3	20.5	21.6	22.7	23.8	25.0	26.1	27.2	28.3	29.5

Linear conveyor modules
LCMR200
Single-axis robots
GX
Linear conveyor modules
LCM100
SCARA robots
YK-X
Single-axis robots
Robomity
Linear motor single-axis robots
PHASER
Single-axis robots
FLIP-X
single-axis robots
TRANSERO
Compact single-axis robots
XX-X
Cartesian robots
XP-X
Pick & place robots
CLEAN
CONTROLLER INFORMATION

MF20/MF20D

● Can be used for wall-mount

Note. When the weight per carrier exceeds 20 kg, special parameters are applicable.



Ordering method

Single carriage model

MF20

Model	Cable carrier entry location	Optional cable carrier for users ^{Note 2}	Origin position change	Grease type	Stroke	Cable length
MF20: Incremental MF20A: Semi-absolute ^{Note 1}	RH: Horizontal, right LH: Horizontal, left RW: Wall mount, right LW: Wall mount, left	No entry: None S: S type M: M type L: L type	Horizontal No entry: L side (Standard) Z: R side Wall No entry: R side (Standard) Z: L side	No entry: Standard GC: Clean	150 to 4050 (100mm pitch)	3L: 3.5m 5L: 5m 10L: 10m 3K/5K/10K (Flexible cable) ^{Note 4}

TSP

Positioner ^{Note 5}	Driver: Power-supply voltage / Power capacity	Regenerative unit	LCD monitor	I/O selection
TS-P	110: 100V/200W 210: 200V/200W	R: With RGT	No entry: None L: With LCD	N: NPN PN: PNP CC: CC-Link DN: DeviceNet™ EP: EtherNet/IP™ GW: No I/O board ^{Note 6}

SR1-P 10

Controller	Driver: Power capacity	Usable for CE	Regenerative unit	I/O selection
	10: 200W	No entry: Standard E: CE marking	R: With RGT1	N: NPN P: PNP CC: CC-Link DN: DeviceNet™ PB: PROFIBUS

RDV-P 2 10 RBR1

Driver	Power-supply voltage	Driver: Power capacity	Regenerative unit
	2: AC200V	10: 200W or less	

Note 1. When RDV-P is selected, the semi-absolute specifications cannot be selected.
 Note 2. For models with a 2,050mm or longer stroke, optional L type cable carriers can only be used.
 Note 3. The robot cable is standard cable (3L/5L/10L), but can be changed to flexible cable. See P.692 for details on robot cable.
 Note 4. If a flexible cable is needed for the SR1-P, TS-P, or RDV-P, then select 3K/5K/10K.
 Note 5. These controllers can be mounted on DIN rails. See P.600 for details.
 Note 6. Select this selection when using the gateway function.
 Note. It is possible to provide the model without a cable carrier. To find information on wiring (cable terminals) within the cable carrier see P.703.

Double carriage model

MF20D

Model	Installing direction	Optional cable carrier for users ^{Note 2}	Grease type	Stroke	Cable length	Controller
MF20D: Incremental MF20AD: Semi-absolute ^{Note 1}	H: Horizontal installation W: Wall mount installation	No entry: None S: S type M: M type L: L type	No entry: Standard GC: Clean	150 to 3850 (100mm pitch)	3L: 3.5m 5L: 5m 10L: 10m 3K/5K/10K (Flexible cable) ^{Note 4}	RCX320 SR1-P (2 units) TS-P (2 units) RDV-P (2 units)

Note. Specify various controller setting items.

Specifications

Model	MF20	MF20D
Driving method	Steel cored linear motor with falt magnet	
Repeatability (µm)	+/-5	
Scale (µm)	Magnetic type: resolution of 1	
Maximum speed ^{Note 2} (mm/sec)	2500	
Rated thrust (N)	86	
Maximum payload ^{Note 1} (kg)	40	
Stroke (mm)	150 to 4050 (100mm pitch)	150 to 3850 (100mm pitch)
Linear guide	4 rows of circular arc grooves x 2 rail W150 x H80	
Maximum cross-section outside dimensions (mm)	(except the cable carrier section)	
Total length (mm)	Stroke+260	Stroke+460
Cable length (m)	Standard: 3.5 / Option: 5.10	

Note. A vertical model (with brake) is not available with the PHASER series.
 Note. The basic specifications of semi-absolute model are the same as those of the incremental model.
 Note 1. Payload per carrier. When the weight exceeds 20 kg, special parameters are applicable. Please consult our sales office or sales representative.
 Note 2. Table of maximum speed

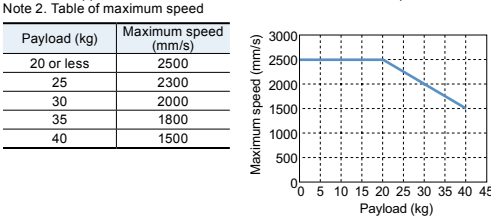

Allowable overhang

Horizontal installation (Unit: mm)

	A	B	C
10kg	3156	1747	1196
15kg	2811	1176	883
20kg	2679	890	717
25kg	2190	720	505
30kg	1830	605	370
35kg	1580	525	275
40kg	1390	465	225

Wall installation (Unit: mm)

	A	B	C
10kg	1220	1320	2540
15kg	870	850	2200
20kg	670	610	2030
25kg	485	400	1280
30kg	350	325	1050
35kg	265	270	890
40kg	235	230	765

Note. Distance from center of slider top to center of gravity of object being carried at a guide service life of 10,000 km.

Static loading moment

MY	MP	MR
373	373	328

(Unit: N·m)

Controller

Controller	Operating method
SR1-P10-R	Programming / I/O point trace / Remote command / Operation using RS-232C communication
RCX320-R RCX340	Operation using RS-232C communication
TS-P110-R	I/O point trace / Remote command
TS-P210-R	Remote command
RDV-P210-RBR1	Pulse train control

Cable carrier entry location

RH Horizontal, right **LH Horizontal, left**

RW Wall mounted, right **LW Wall mounted, left**

Note. Be sure to install in the direction as specified (in cable carrier take-out direction drawing and various specification drawings) individually. Installation in any other way will cause a failure. For requirement of installation in any way other than the above standard installation, please consult YAMAHA as special arrangement will be available.

Optional cable carrier for users

S type **M type** **L type**

Cable and air tube guide

S: φ8 flexible cable x 1, φ4 air tube x 1
 M: φ8 flexible cable x 2, φ6 air tube x 2
 L: φ8 flexible cable x 2, φ6 air tube x 3

Space for optional cable for users

MF20 single carriage horizontal mount model **RH**

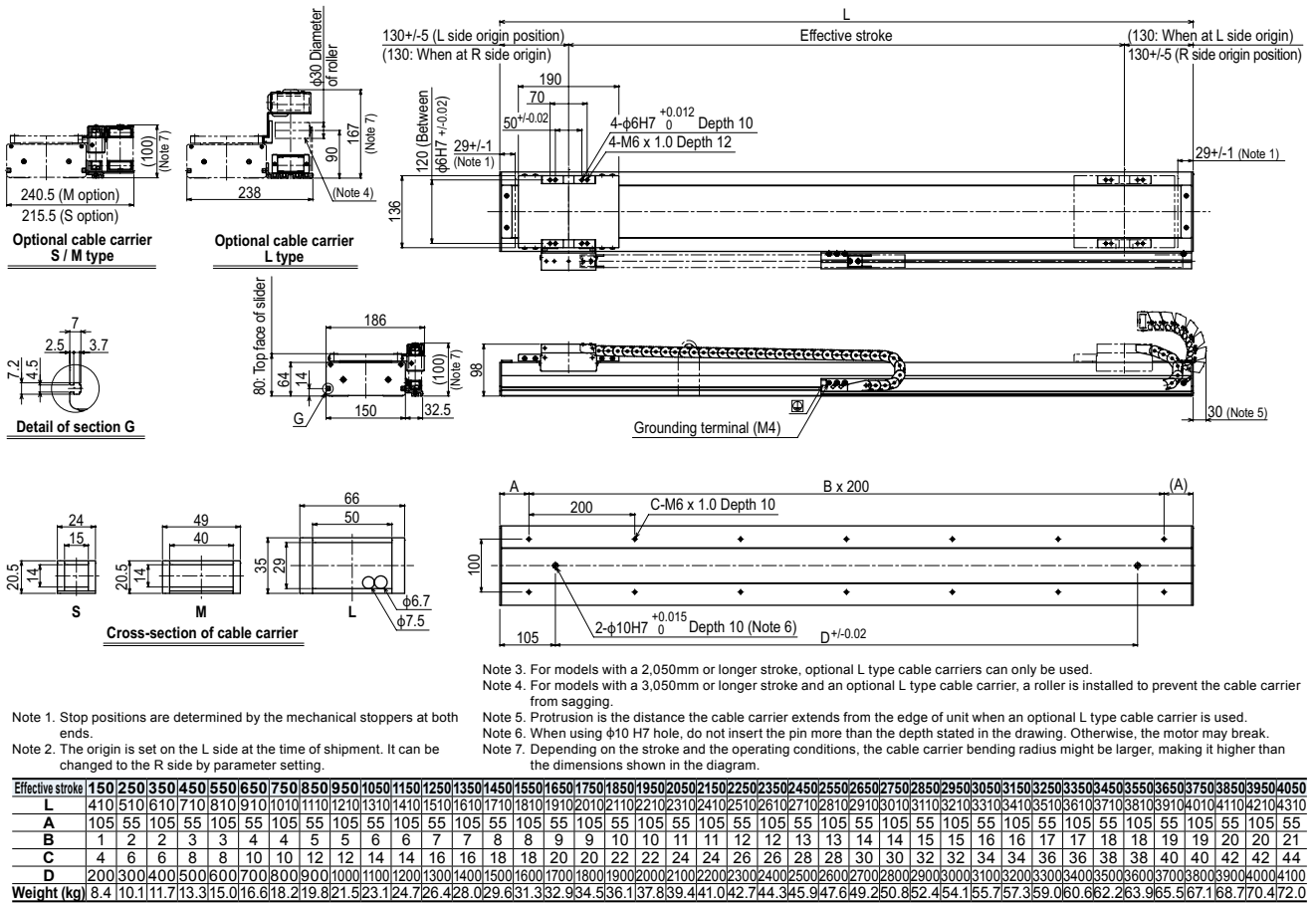

MF20 single carriage wall mount model **RW**

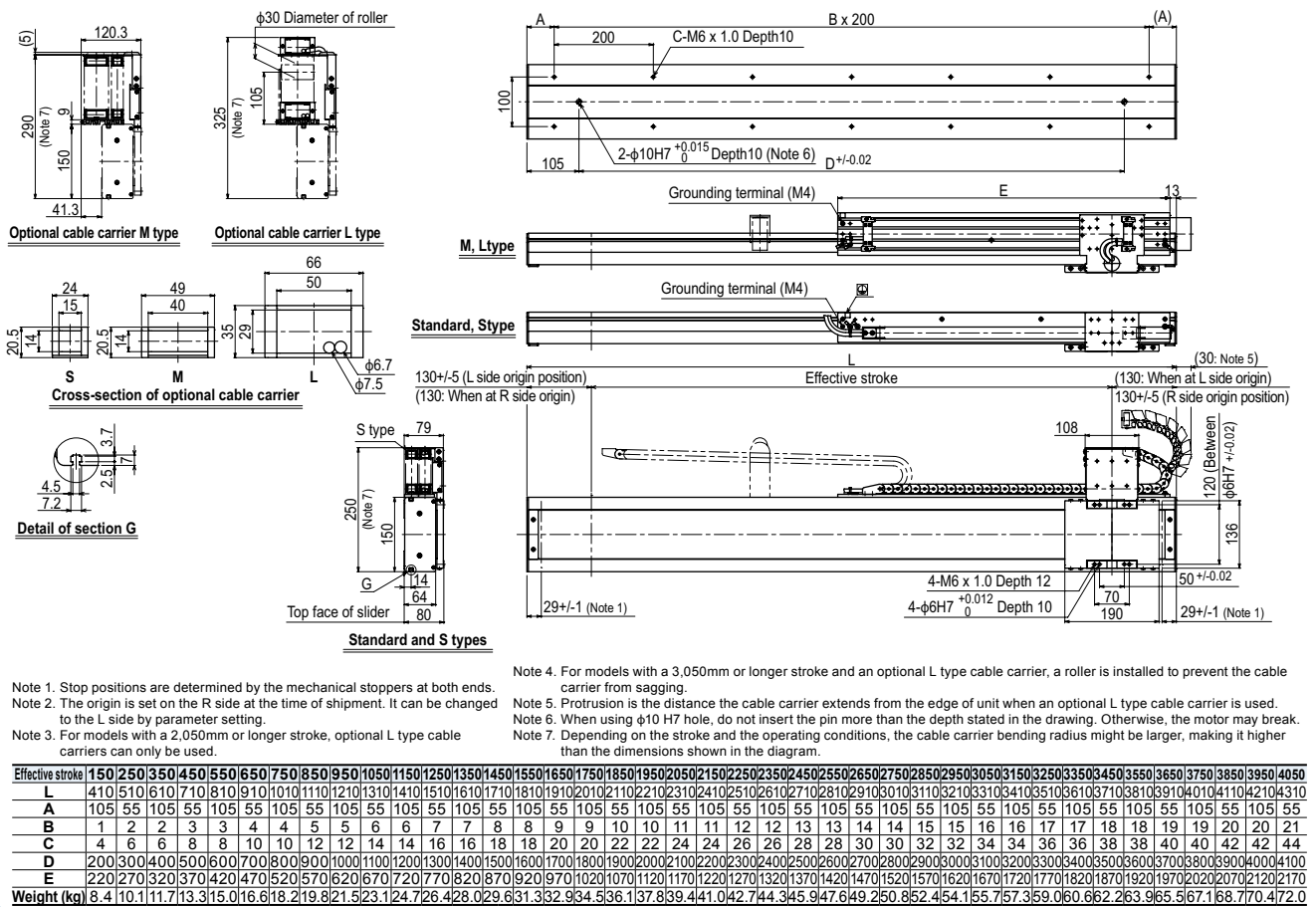

Linear conveyor modules
LCMR200

Single-axis robots
GX

Linear conveyor modules
LCM100

SCARA robots
YK-X

Single-axis robots
Robomity

Linear motor single-axis robots
PHASER

Single-axis robots
FLIP-X

Compact single-axis robots
TRANSERO

Cartesian robots
XX-X

Pick & place robots
YP-X

CLEAN

CONTROLLER INFORMATION

MF20D double carriage horizontal mount model H

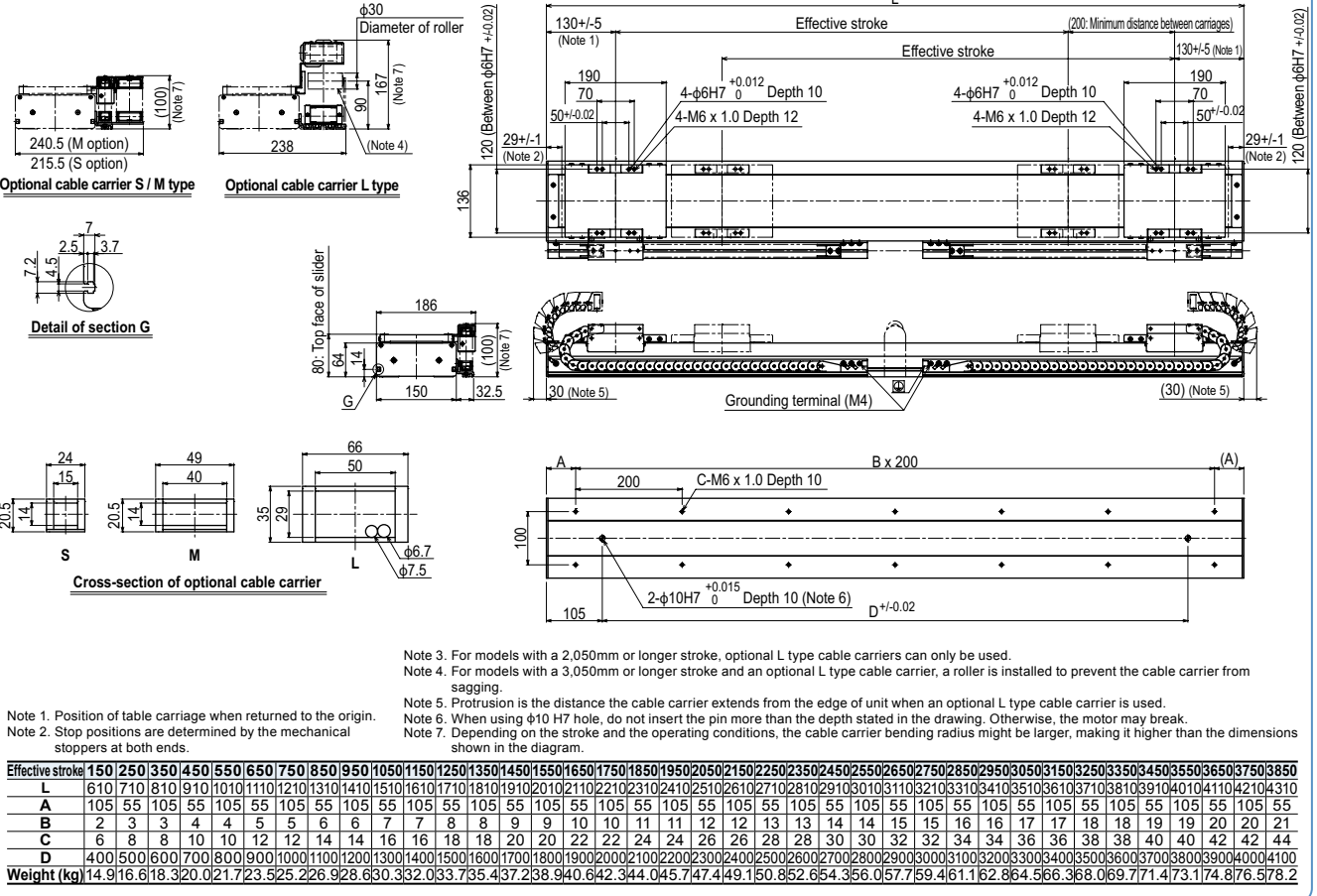

MF20D double carriage wall mount model W

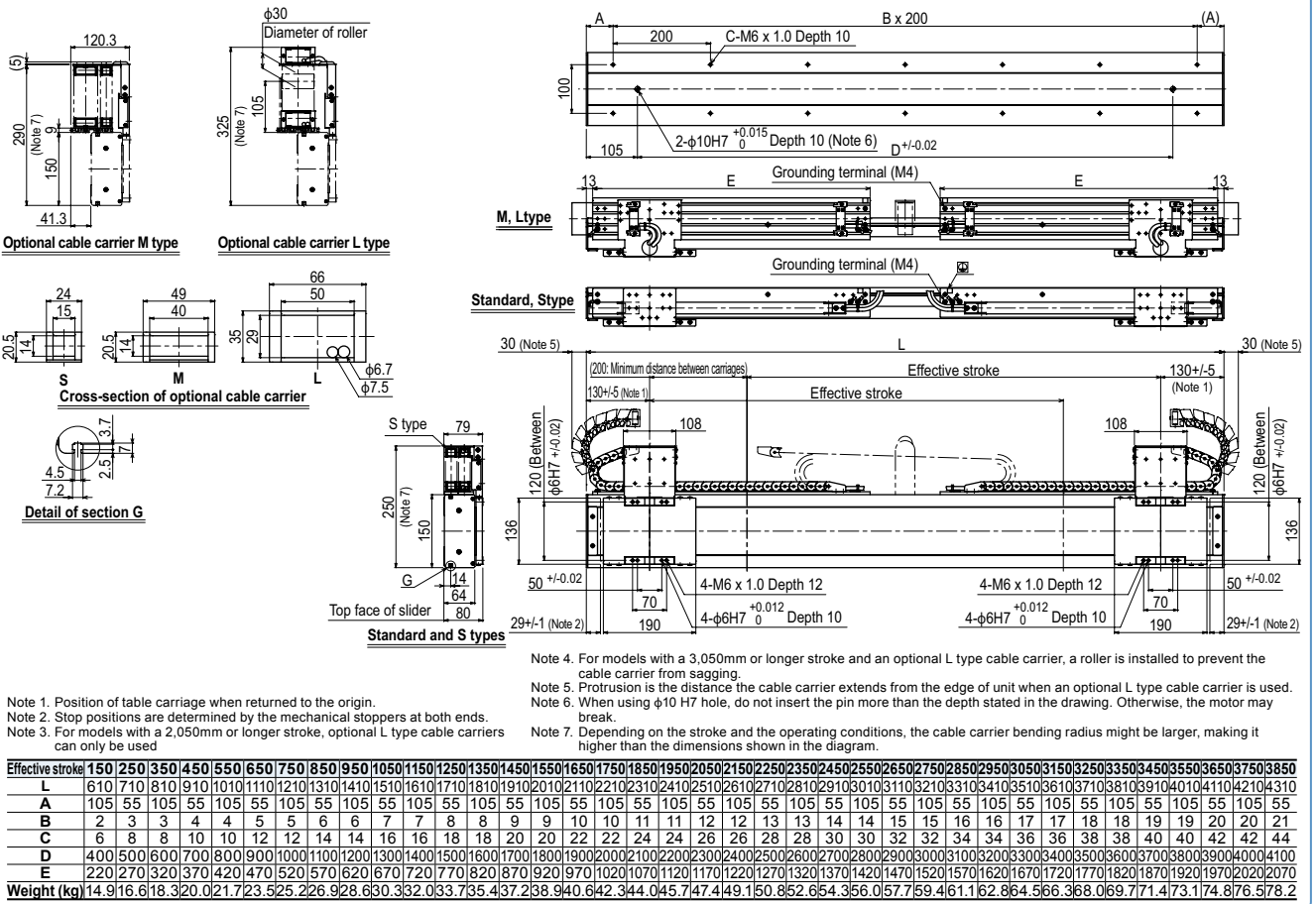

MF30/MF30D

Can be used for wall-mount

Note. When the weight per carrier exceeds 30 kg, special parameters are applicable.



Ordering method

Single carriage model

MF30

Model MF30: Incremental MF30A: Semi-absolute ^{Note 1}	Cable carrier entry location RH: Horizontal, right LH: Horizontal, left RW: Wall mount, right LW: Wall mount, left	Optional cable carrier for users^{Note 2} No entry: None S: S type M: M type L: L type	Origin position change Horizontal: No entry: L side (Standard) Z: R side Wall: No entry: R side (Standard) Z: L side	Grease type No entry: Standard GC: Clean	Stroke 100 to 4000 (100mm pitch)	Cable length^{Note 3} 3L: 3.5m 5L: 5m 10L: 10m 3K/5K/10K (Flexible cable) ^{Note 4}
---	---	---	---	---	--	--

TSP 220 R

Positioner^{Note 5} TS-P	Driver: Power-supply voltage / Power capacity 220: 200V/400 to 600W	Regenerative unit R: With RGT	LCD monitor No entry: None L: With LCD	I/O selection NP: NPN PN: PNP CC: CC-Link DN: DeviceNet™ EP: EtherNet/IP™ GW: No I/O board ^{Note 6}
--	---	---	---	---

SR1-P 20 R

Controller^{Note 5}	Driver: Power capacity 20: 400 to 600W	Usable for CE No entry: Standard E: CE marking	Regenerative unit R: With RGT	I/O selection N: NPN P: PNP CC: CC-Link DN: DeviceNet™ EP: EtherNet/IP™ PB: PROFIBUS
------------------------------------	--	---	---	---

RDV-P 2 20 RBR1

Driver	Power-supply voltage 2: AC200V	Driver: Power capacity 20: 400W or less	Regenerative unit
---------------	--	---	--------------------------

Note 1. When RDV-P is selected, the semi-absolute specifications cannot be selected.
 Note 2. For models with a stroke of 2100 or longer (2050 or longer for double carriage models), only the optional L type cable carriers can be used.
 Note 3. The robot cable is standard cable (3L/5L/10L), but can be changed to flexible cable. See P.692 for details on robot cable.
 Note 4. If a flexible cable is needed for the SR1-P, TS-P, or RDV-P, then select 3K/5K/10K.
 Note 5. These controllers can be mounted on DIN rails. See P.600 for details.
 Note 6. Select this selection when using the gateway function.
 Note. It is possible to provide the model without a cable carrier. To find information on wiring (cable terminals) within the cable carrier see P.703.

Double carriage model

MF30D

Model MF30D: Incremental MF30AD: Semi-absolute ^{Note 1}	Installing direction H: Horizontal installation W: Wall mount installation	Optional cable carrier for users^{Note 2} No entry: None S: S type M: M type L: L type	Grease type No entry: Standard GC: Clean	Stroke 150 to 3750 (100mm pitch)	Cable length 3L: 3.5m 5L: 5m 10L: 10m 3K/5K/10K (Flexible cable) ^{Note 4}	Controller RCX320 SR1-P (2 units) TS-P (2 units) RDV-P (2 units)
---	---	---	---	--	---	---

Note. Specify various controller setting items.

Specifications

Model	MF30	MF30D
Driving method	Steel cored linear motor with falt magnet	
Repeatability (μm)	+/-5	
Scale (μm)	Magnetic type: resolution of 1	
Maximum speed^{Note 2} (mm/sec)	2500	
Rated thrust (N)	125	
Maximum payload^{Note 1} (kg)	60	
Stroke (mm)	100 to 4000 (100mm pitch)	150 to 3750 (100mm pitch)
Linear guide	4 rows of circular arc grooves x 2 rail	
Maximum cross-section outside dimensions (mm)	W150 x H80 (except the cable carrier section)	
Total length (mm)	Stroke+310	Stroke+560
Cable length (m)	Standard: 3.5 / Option: 5,10	

Note. A vertical model (with brake) is not available with the PHASER series.
 Note. The basic specifications of semi-absolute model are the same as those of the incremental model.
 Note 1. Payload per carrier. When the weight exceeds 30 kg, special parameters are applicable. Please consult our sales office or sales representative.
 Note 2. Table of maximum speed

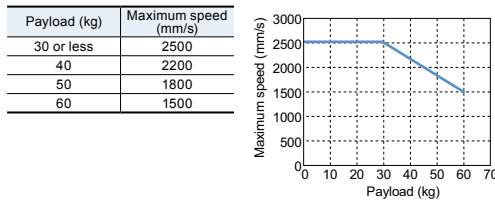

Allowable overhang

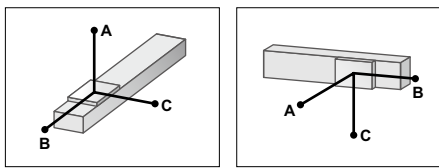

	Horizontal installation (Unit: mm)			Wall installation (Unit: mm)		
	A	B	C	A	B	C
10kg	3364	2485	1284	1290	1320	2730
20kg	2298	1265	694	650	610	1750
30kg	2060	859	507	430	360	1460
40kg	1570	600	310	205	230	610
50kg	1265	400	180	145	175	470
60kg	1070	350	135	105	140	380

Note. Distance from center of slider top to center of gravity of object being carried at a guide service life of 10,000 km.

Static loading moment

MY	MP	MR
373	373	328

(Unit: N-m)

Controller

Controller	Operating method
SR1-P20-R	Programming / I/O point trace / Remote command / Operation using RS-232C communication
RCX320-R RCX340	I/O point trace / Remote command
TS-P220-R	Pulse train control
RDV-P220-RBR1	

Cable carrier entry location

RH Horizontal, right **LH Horizontal, left**

RW Wall mounted, right **LW Wall mounted, left**

Note. Be sure to install in the direction as specified (in cable carrier take-out direction drawing and various specification drawings) individually. Installation in any other way will cause a failure. For requirement of installation in any way other than the above standard installation, please consult YAMAHA as special arrangement will be available.

Optional cable carrier for users

S type **M type** **L type**

Cable and air tube guide

S: φ8 flexible cable x 1, φ4 air tube x 1
 M: φ8 flexible cable x 2, φ6 air tube x 2
 L: φ8 flexible cable x 2, φ6 air tube x 3

Space for optional cable for users

Controller

SR1-P ▶ 618 **RCX320 ▶ 626** **TS-P ▶ 592** **RDV-P ▶ 606**

MF30D double carriage horizontal mount model **H**

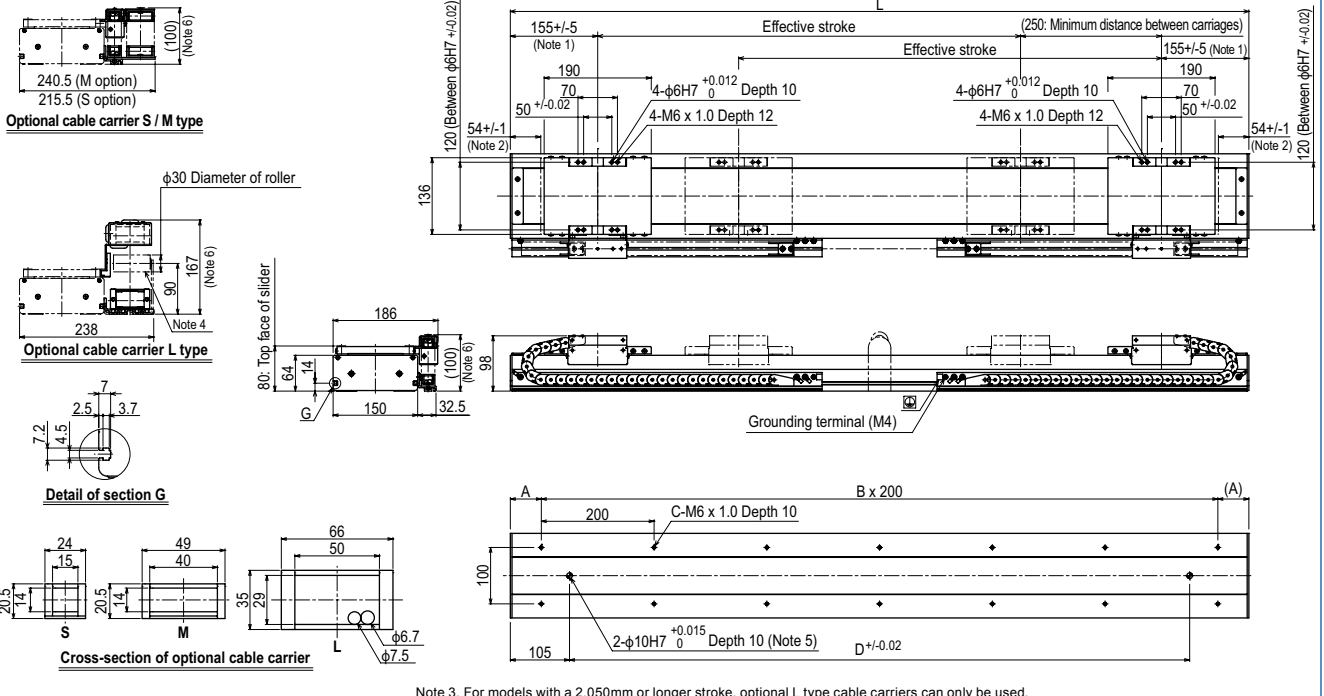

Note 1. Position of table carriage when returned to the origin.
 Note 2. Stop positions are determined by the mechanical stoppers at both ends.
 Note 3. For models with a 2,050mm or longer stroke, optional L type cable carriers can only be used.
 Note 4. For models with a 3,050mm or longer stroke and an optional L type cable carrier, a roller is installed to prevent the cable carrier from sagging.
 Note 5. When using $\phi 10$ H7 hole, do not insert the pin more than the depth stated in the drawing. Otherwise, the motor may break.
 Note 6. Depending on the stroke and the operating conditions, the cable carrier bending radius might be larger, making it higher than the dimensions shown in the diagram.

Effective stroke	150	250	350	450	550	650	750	850	950	1050	1150	1250	1350	1450	1550	1650	1750	1850	1950	2050	2150	2250	2350	2450	2550	2650	2750	2850	2950	3050	3150	3250	3350	3450	3550	3650	3750		
L	710	810	910	1010	1110	1210	1310	1410	1510	1610	1710	1810	1910	2010	2110	2210	2310	2410	2510	2610	2710	2810	2910	3010	3110	3210	3310	3410	3510	3610	3710	3810	3910	4010	4110	4210	4310		
A	55	105	55	105	55	105	55	105	55	105	55	105	55	105	55	105	55	105	55	105	55	105	55	105	55	105	55	105	55	105	55	105	55	105	55	105	55	105	55
B	3	3	4	4	5	5	6	6	7	7	8	8	9	9	10	10	11	11	12	12	13	13	14	14	15	15	16	16	17	17	18	18	19	19	20	20	21	21	
C	8	8	10	10	12	12	14	14	16	16	18	18	20	20	22	22	24	24	26	26	28	28	30	30	32	32	34	34	36	36	38	38	40	40	42	42	44	44	
D	500	600	700	800	900	1000	1100	1200	1300	1400	1500	1600	1700	1800	1900	2000	2100	2200	2300	2400	2500	2600	2700	2800	2900	3000	3100	3200	3300	3400	3500	3600	3700	3800	3900	4000	4100	4200	
Weight (kg)	17.6	19.3	21.0	22.8	24.5	26.2	27.9	29.6	31.3	33.0	34.7	36.3	38.0	39.7	41.4	43.1	44.8	46.5	48.2	49.9	51.6	53.3	55.0	56.7	58.4	60.1	61.8	63.5	65.2	66.9	68.6	70.3	72.0	73.7	75.4	77.1	78.8	80.5	

MF30D double carriage wall mount model **W**

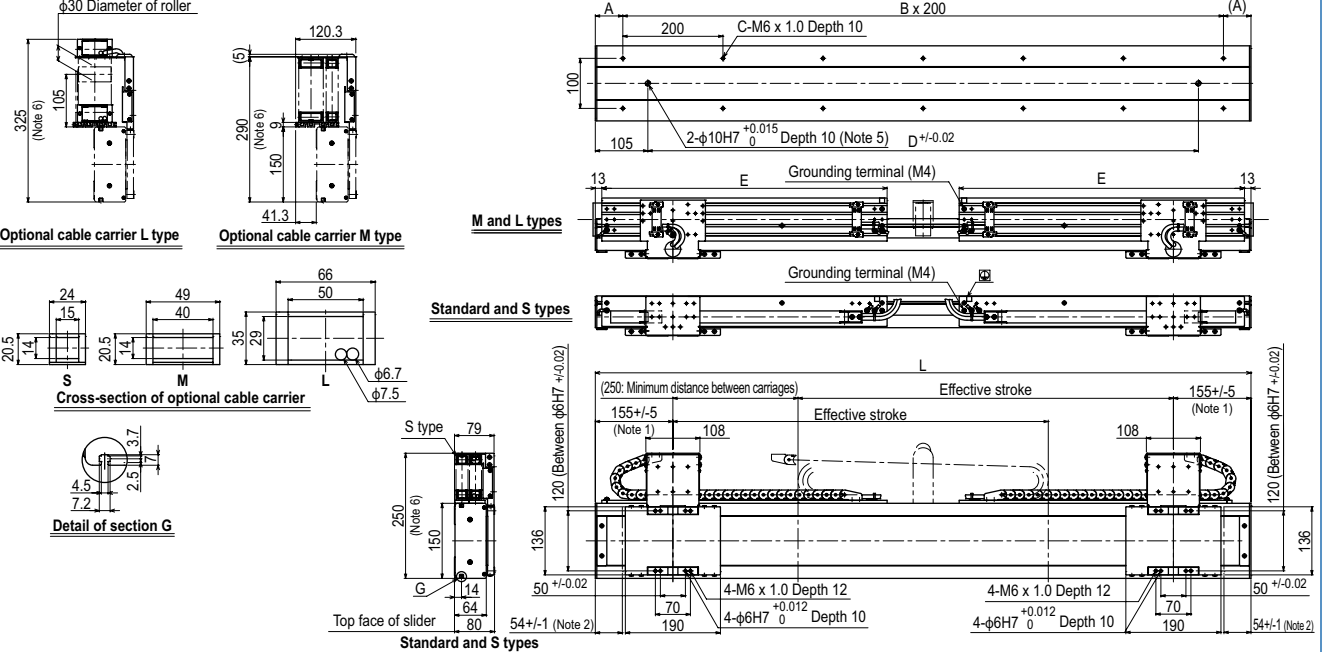

Note 1. Position of table carriage when returned to the origin.
 Note 2. Stop positions are determined by the mechanical stoppers at both ends.
 Note 3. For models with a 2,050mm or longer stroke, optional L type cable carriers can only be used.
 Note 4. For models with a 3,050mm or longer stroke and an optional L type cable carrier, a roller is installed to prevent the cable carrier from sagging.
 Note 5. When using $\phi 10$ H7 hole, do not insert the pin more than the depth stated in the drawing. Otherwise, the motor may break.
 Note 6. Depending on the stroke and the operating conditions, the cable carrier bending radius might be larger, making it higher than the dimensions shown in the diagram.

Effective stroke	150	250	350	450	550	650	750	850	950	1050	1150	1250	1350	1450	1550	1650	1750	1850	1950	2050	2150	2250	2350	2450	2550	2650	2750	2850	2950	3050	3150	3250	3350	3450	3550	3650	3750		
L	710	810	910	1010	1110	1210	1310	1410	1510	1610	1710	1810	1910	2010	2110	2210	2310	2410	2510	2610	2710	2810	2910	3010	3110	3210	3310	3410	3510	3610	3710	3810	3910	4010	4110	4210	4310		
A	55	105	55	105	55	105	55	105	55	105	55	105	55	105	55	105	55	105	55	105	55	105	55	105	55	105	55	105	55	105	55	105	55	105	55	105	55	105	55
B	3	3	4	4	5	5	6	6	7	7	8	8	9	9	10	10	11	11	12	12	13	13	14	14	15	15	16	16	17	17	18	18	19	19	20	20	21	21	
C	8	8	10	10	12	12	14	14	16	16	18	18	20	20	22	22	24	24	26	26	28	28	30	30	32	32	34	34	36	36	38	38	40	40	42	42	44	44	
D	500	600	700	800	900	1000	1100	1200	1300	1400	1500	1600	1700	1800	1900	2000	2100	2200	2300	2400	2500	2600	2700	2800	2900	3000	3100	3200	3300	3400	3500	3600	3700	3800	3900	4000	4100	4200	
E	220	270	320	370	420	470	520	570	620	670	720	770	820	870	920	970	1020	1070	1120	1170	1220	1270	1320	1370	1420	1470	1520	1570	1620	1670	1720	1770	1820	1870	1920	1970	2020		
Weight (kg)	17.6	19.3	21.0	22.8	24.5	26.2	27.9	29.6	31.3	33.0	34.7	36.3	38.0	39.7	41.4	43.1	44.8	46.5	48.2	49.9	51.6	53.3	55.0	56.7	58.4	60.1	61.8	63.5	65.2	66.9	68.6	70.3	72.0	73.7	75.4	77.1	78.8	80.5	

MF75/MF75D

Note. When the weight per carrier exceeds 75 kg, special parameters are applicable.



Ordering method

Single carriage model

MF75

Model MF75: Incremental MF75A: Semi-absolute ^{Note 1}	Cable carrier entry location RH: Horizontal, right LH: Horizontal, left	Origin position change No entry: L side (Standard) Z: R side	Grease type No entry: Standard GC: Clean	Stroke 1000 to 4000 (100mm pitch)	Cable length ^{Note 2} 3L: 3.5m 5L: 5m 10L: 10m 3K/5K/10K (Flexible cable) ^{Note 3}	TSP Positioner ^{Note 4} TS-P	220 Driver: Power-supply voltage / Power capacity 220: 200V/400 to 600W	R Regenerative unit R: With RGU-2	LCD monitor No entry: None L: With LCD	I/O selection NP: NPN PN: PNP CC: CC-Link DN: DeviceNet™ EP: EtherNet/IP™ GW: No I/O board ^{Note 5}
---	--	---	---	---	---	--	--	--	---	---

SR1-P

Controller	20 Driver: Power capacity 20: 400 to 600W	Usable for CE No entry: Standard E: CE marking	R Regenerative unit R: With RGU-2	I/O selection N: NPN P: PNP CC: CC-Link DN: DeviceNet™ PB: PROFIBUS
-------------------	--	---	--	---

RDV-P

Driver	2 Power-supply voltage 2: AC200V	25 Driver: Power capacity 25: 750W or less	RBR2 Regenerative unit
---------------	---	---	----------------------------------

Note 1. When RDV-P is selected, the semi-absolute specifications cannot be selected.
 Note 2. The robot cable is standard cable (3L/5L/10L), but can be changed to flexible cable. See P.692 for details on robot cable.
 Note 3. If a flexible cable is needed for the SR1-P, TS-P, or RDV-P, then select 3K/5K/10K.
 Note 4. These controllers can be mounted on DIN rails. See P.600 for details.
 Note 5. Select this selection when using the gateway function.
 Note. It is possible to provide the model without a cable carrier. To find information on wiring (cable terminals) within the cable carrier see P.703.

Double carriage model

MF75D - **H**

Model MF75D: Incremental MF75AD: Semi-absolute ^{Note 1}	Installing direction H: Horizontal installation	Grease type No entry: Standard GC: Clean	Stroke 680 to 3680 (100mm pitch)	Cable length 3L: 3.5m 5L: 5m 10L: 10m 3K/5K/10K (Flexible cable) ^{Note 3}	Controller RCX320 SR1-P (2 units) TS-P (2 units) RDV-P (2 units)
---	---	---	--	---	---

Note. Specify various controller setting items.

Specifications

Model	MF75	MF75D
Driving method	Steel cored linear motor with falt magnet	
Repeatability (µm)	+/-5	
Scale (µm)	Magnetic type: resolution of 1	
Maximum speed^{Note 2} (mm/sec)	2500	
Rated thrust (N)	260	
Maximum payload^{Note 1} (kg)	160	
Stroke (mm)	1000 to 4000 (100mm pitch)	680 to 3680 (100mm pitch)
Linear guide	4 rows of circular arc grooves x 2 rail	
Maximum cross-section outside dimensions (mm)	W210xH100 (except the cable carrier section)	
Total length (mm)	Stroke+360	Stroke+680
Cable length (m)	Standard: 3.5 / Option: 5,10	

Note. A vertical model (with brake) is not available with the PHASER series.
 Note. The basic specifications of semi-absolute model are the same as those of the incremental model.

Note 1. Payload per carrier. When the weight exceeds 75 kg, special parameters are applicable. Please consult our sales office or sales representative.

Note 2. Table of maximum speed

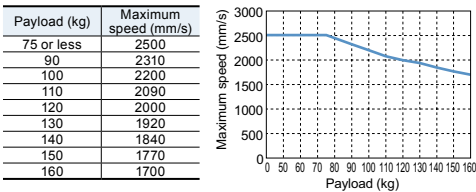

Allowable overhang

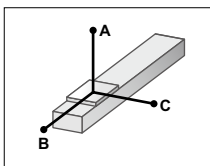

Horizontal installation (Unit: mm)

	A	B	C
20kg	3397	2841	1840
40kg	2795	1389	964
60kg	2200	530	450
80kg	1800	175	150
100kg	1500	130	110
120kg	1250	100	80
140kg	1100	80	65
160kg	950	60	50

Note. Distance from center of slider top to center of gravity of object being carried at a guide service life of 10,000 km.

Static loading moment

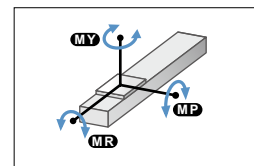

(Unit: N-m)

MY	MP	MR
830	831	730

Controller

Controller	Operating method
SR1-P20-R	Programming / I/O point trace /
RCX320-R RCX340	Remote command / Operation using RS-232C communication
TS-P220-R	I/O point trace / Remote command
RDV-P225-RBR2	Pulse train control

Cable carrier entry location

RH Horizontal, right **LH Horizontal, left**

Note. Be sure to install in the direction as specified (in cable carrier take-out direction drawing and various specification drawings) individually. Installation in any other way will cause a failure. For requirement of installation in any way other than the above standard installation, please consult YAMAHA as special arrangement will be available.

Cable carrier

Cable and air tube guide φ8 flexible cable x 2, φ6 air tube x 3

Space for optional cable for users

MF75 single carriage horizontal mount model **RH**

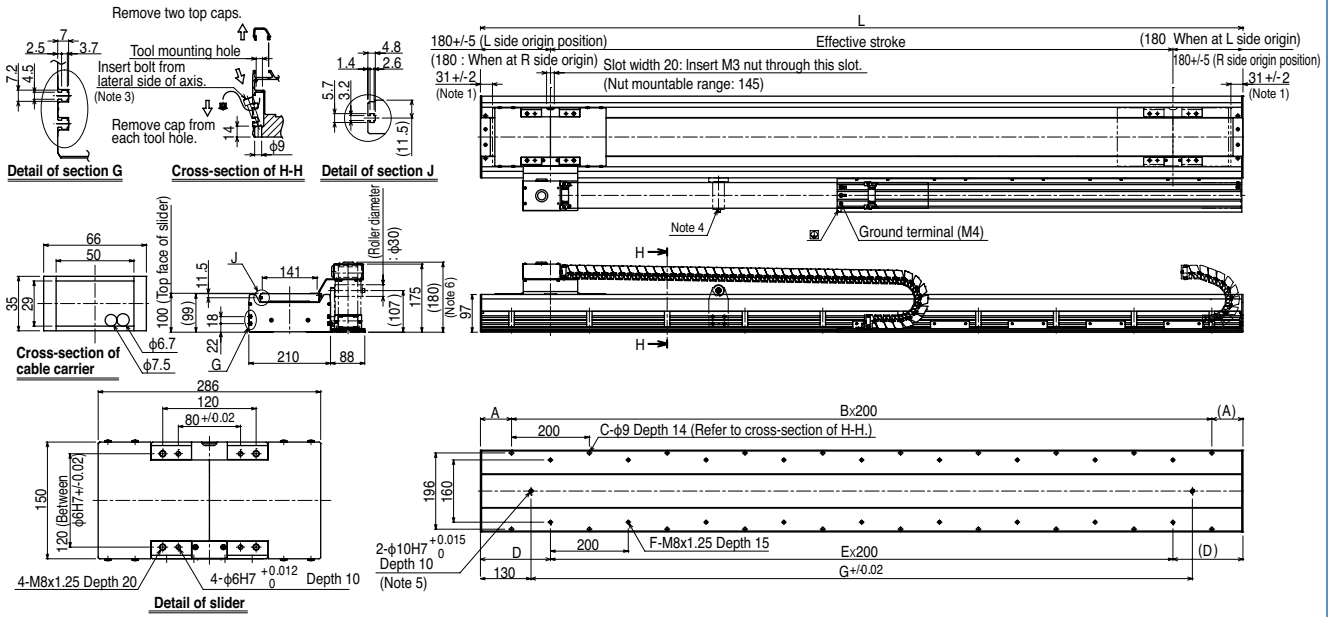

Note 1. Stop positions are determined by the mechanical stoppers at both ends.
 Note 2. The origin is set on the L side (as shown above) at the time of shipment. It can be changed to the R side by parameter setting.
 Note 3. The length under head of M8 hex socket head bolts for installing the robot body must not be longer than 30mm.
 Note 4. For models with a 3,000mm or longer stroke, a roller is installed to prevent the cable carrier from sagging.
 Note 5. When using φ10 H7 hole, do not insert the pin more than the depth stated in the drawing. Otherwise, the motor may break.
 Note 6. Depending on the stroke and the operating conditions, the cable carrier bending radius might be larger, making it higher than the dimensions shown in the diagram.

Effective stroke	1000	1100	1200	1300	1400	1500	1600	1700	1800	1900	2000	2100	2200	2300	2400	2500	2600	2700	2800	2900	3000	3100	3200	3300	3400	3500	3600	3700	3800	3900	4000
L	1360	1460	1560	1660	1760	1860	1960	2060	2160	2260	2360	2460	2560	2660	2760	2860	2960	3060	3160	3260	3360	3460	3560	3660	3760	3860	3960	4060	4160	4260	4360
A	180	230	80	130	180	230	80	130	180	230	80	130	180	230	80	130	180	230	80	130	180	230	80	130	180	230	80	130	180	230	80
B	5	5	7	7	7	7	9	9	9	9	11	11	11	11	13	13	13	13	13	15	15	15	17	17	17	17	19	19	19	19	21
C	12	12	16	16	16	16	20	20	20	20	24	24	24	24	28	28	28	28	28	32	32	32	32	36	36	36	36	40	40	40	44
D	80	130	180	230	80	130	180	230	80	130	180	230	80	130	180	230	80	130	180	230	80	130	180	230	80	130	180	230	80	130	180
E	6	6	6	6	8	8	8	8	10	10	10	10	12	12	12	12	14	14	14	14	16	16	16	16	18	18	18	18	20	20	20
F	14	14	14	14	18	18	18	18	22	22	22	22	26	26	26	26	30	30	30	30	34	34	34	34	38	38	38	38	42	42	42
G	1100	1200	1300	1400	1500	1600	1700	1800	1900	2000	2100	2200	2300	2400	2500	2600	2700	2800	2900	3000	3100	3200	3300	3400	3500	3600	3700	3800	3900	4000	4100
Weight (kg)	46	49	51	54	56	59	61	64	66	69	71	74	76	79	81	84	86	89	91	94	96	99	101	104	106	109	111	114	116	119	121

MF75D double carriage mount model **H**

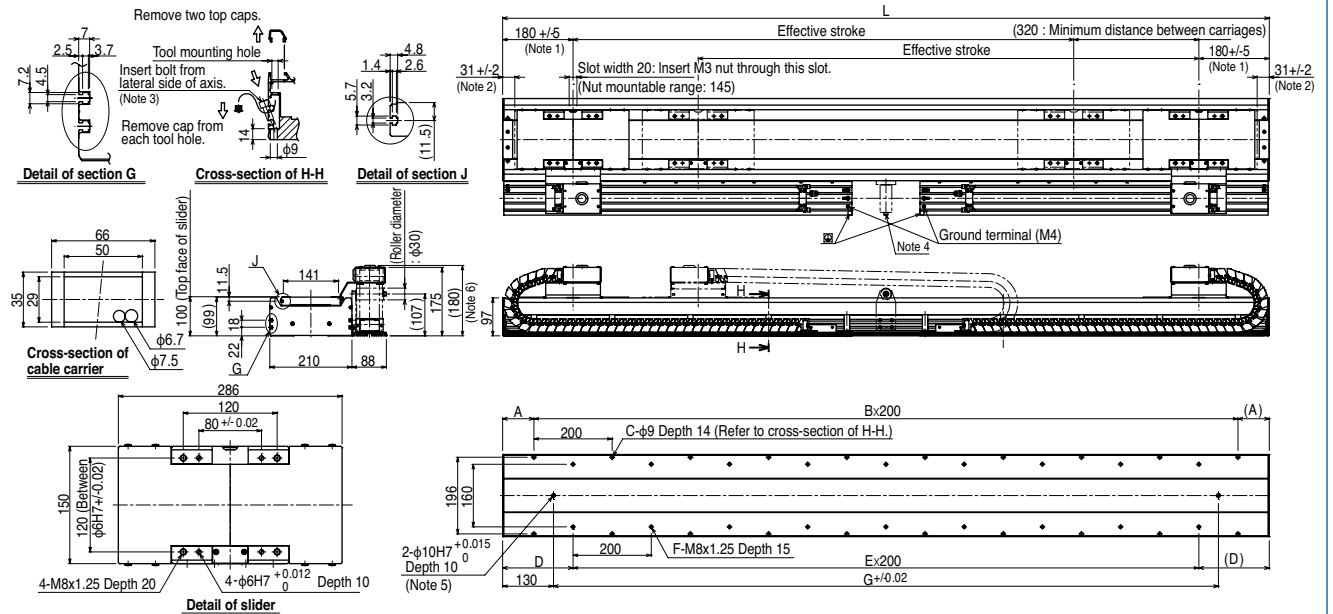

Note 1. Position of table carriage when returned to the origin.
 Note 2. Stop positions are determined by the mechanical stoppers at both ends.
 Note 3. The length under head of M8 hex socket head bolts for installing the robot body must not be longer than 30mm.
 Note 4. For models with a 3,080mm or longer stroke, a roller is installed to prevent the cable carrier from sagging.
 Note 5. When using φ10 H7 hole, do not insert the pin more than the depth stated in the drawing. Otherwise, the motor may break.
 Note 6. Depending on the stroke and the operating conditions, the cable carrier bending radius might be larger, making it higher than the dimensions shown in the diagram.

Effective stroke	680	780	880	980	1080	1180	1280	1380	1480	1580	1680	1780	1880	1980	2080	2180	2280	2380	2480	2580	2680	2780	2880	2980	3080	3180	3280	3380	3480	3580	3680
L	1360	1460	1560	1660	1760	1860	1960	2060	2160	2260	2360	2460	2560	2660	2760	2860	2960	3060	3160	3260	3360	3460	3560	3660	3760	3860	3960	4060	4160	4260	4360
A	180	230	80	130	180	230	80	130	180	230	80	130	180	230	80	130	180	230	80	130	180	230	80	130	180	230	80	130	180	230	80
B	5	5	7	7	7	7	9	9	9	9	11	11	11	11	13	13	13	13	13	15	15	15	17	17	17	17	19	19	19	19	21
C	12	12	16	16	16	16	20	20	20	20	24	24	24	24	28	28	28	28	28	32	32	32	32	36	36	36	36	40	40	40	44
D	80	130	180	230	80	130	180	230	80	130	180	230	80	130	180	230	80	130	180	230	80	130	180	230	80	130	180	230	80	130	180
E	6	6	6	6	8	8	8	8	10	10	10	10	12	12	12	12	14	14	14	14	16	16	16	16	18	18	18	18	20	20	20
F	14	14	14	14	18	18	18	18	22	22	22	22	26	26	26	26	30	30	30	30	34	34	34	34	38	38	38	38	42	42	42
G	1100	1200	1300	1400	1500	1600	1700	1800	1900	2000	2100	2200	2300	2400	2500	2600	2700	2800	2900	3000	3100	3200	3300	3400	3500	3600	3700	3800	3900	4000	4100
Weight (kg)	57	60	62	65	67	70	73	75	78	81	83	86	88	91	94	96	99	101	104	107	109	112	114	117	120	122	125	127	130	133	135