

HT SERIES

High Torque Brushless 3-Phase DC Motor

The HT is a new revolutionary high torque motor. Compared to other brushless motors, the HT Motor has a flat torque-speed curve meaning that the speed is less influenced when the torque is increased. The secret to that is found how the magnetic circuit is built. A combination of SMAC's patent pending Halbach magnets and printed coil technology.



Features

- Brushless. No wear on brushes leading to a longer motor life.
- Higher torque without gearing which eliminates additional cost.
- No backlash from gearing.
- No friction from brushes.
- No pollution from worn brushes.
- No voltage-drop on brushes ("brush drop").
- No sparking on brushes.
- Printed coil allows coil shapes impossible to achieve with conventional winding technology.
- Many applications require torque not high speed.
- SMAC offers a range of small high resolution encoders.
- Competitive pricing.

Product Part Number

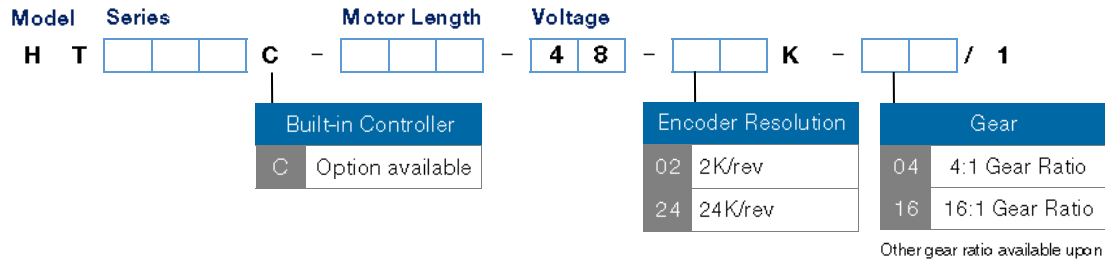

Specifications

Model	HT035	HT055
Apply Voltage [VDC]	48	48
Power [W]	26	37.8
Terminal Resistance (phase to phase) [Ohm]	8.3	8.3
Efficiency, maximum [%]	72.7	85
No-load speed [RPM]	3400	851
No-load current [A]	0.041	0.36
Stall torque [mNm]	560	1995
Stall current [A]	4.7	6
Friction torque (static) [mNm]	10.1	TBA
Friction torque (dynamic) [mNm]	6.6	TBA
Speed constant [RPM/V]	66.2	TBA
Back-EMF constant [V/RPM]	14.7	50.4
Torque constant [mNm/A]	110	333
Current constant [A/mNm]	0.02	TBA
speed of n-M-curve (speed/Torque gradient) [RPM/mNm]	4.85	0.34
Terminal inductance (phase to phase) [mH]	0.711	4.5
Mechanical time constant [ms]	12	3.3
Rotor inertia [grcm ²]	136	940
Angular acceleration [10x3 rod/s ²]	28.3	TBA
Thermal resistance (winding to housing) [K/W]	1.9	0.36
Thermal resistance (housing to ambient) [K/W]	10.4	6.4
Thermal time constant (housing) ms [s]	1390	TBA
Thermal time constant (coil) ms [s]	33	TBA
Motor type	Brushless	Brushless
Pole pair	6	6
Rotor mass [gr]	140	350
Total mass [gr]	256	980
Encoder Option	2K or 24K	2K or 24K
Gearbox Option	4:1 or 16:1	4:1 or 16:1
Controller Option	Built-in Servo Controller	Built-in Servo Controller
Note: The measured data based on the total of resistance including motor and 3m cable		
Terminal resistance in testing (ohm) (motor & cable)	8.9	8.9

Package Dimensions (Mode: HT035 Series)

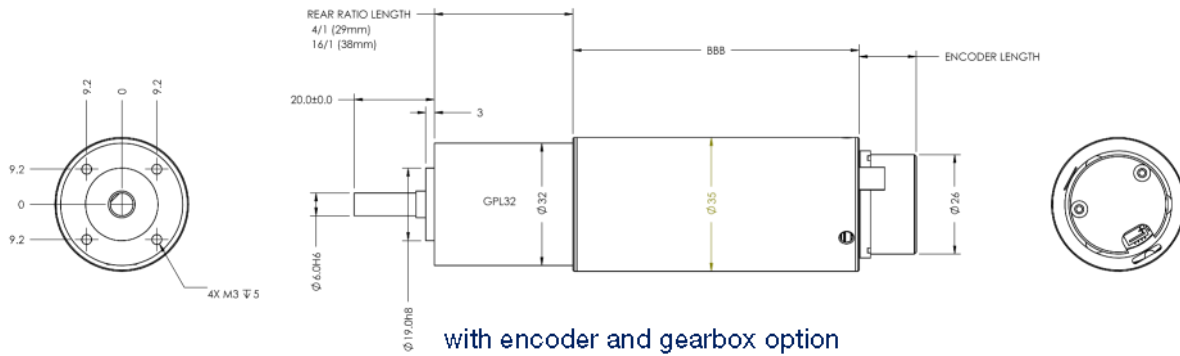
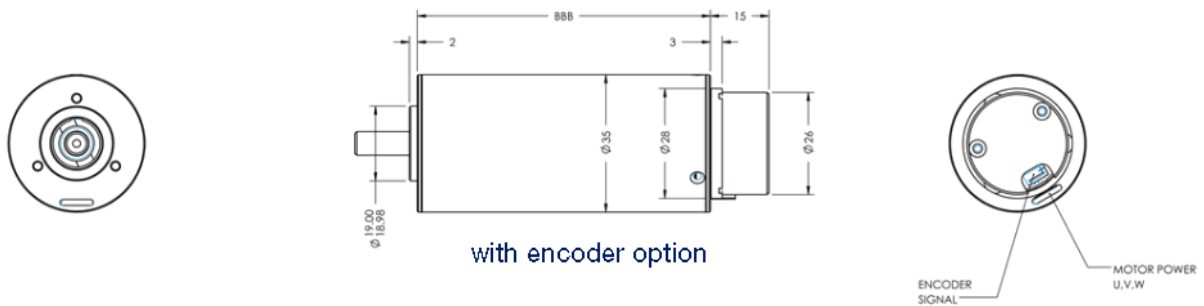
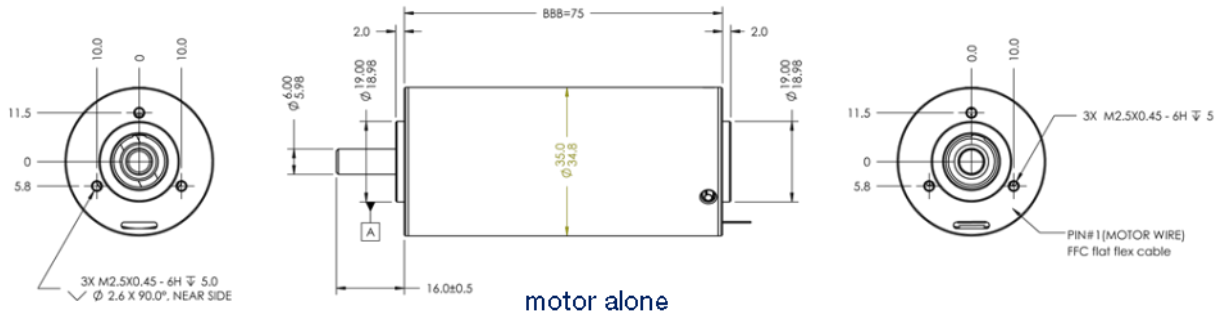

Operating Range (HT035)

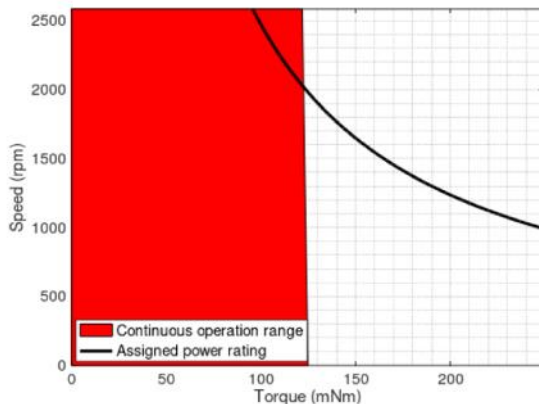

Speed, Torque, Efficiency Characteristics (HT035)

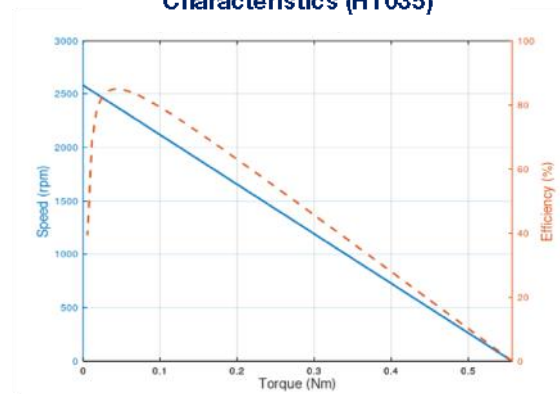

Package Dimensions (Mode: HT055 Series)

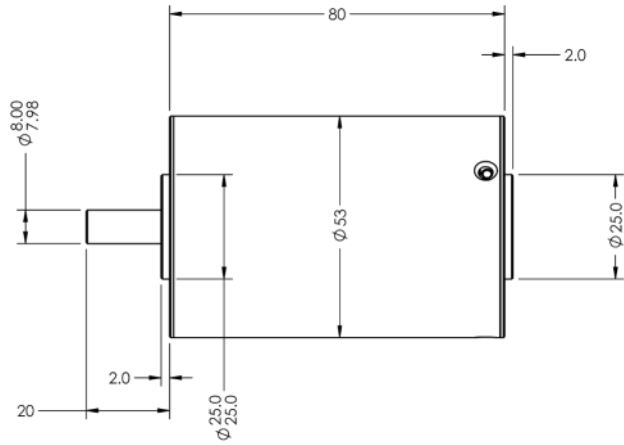
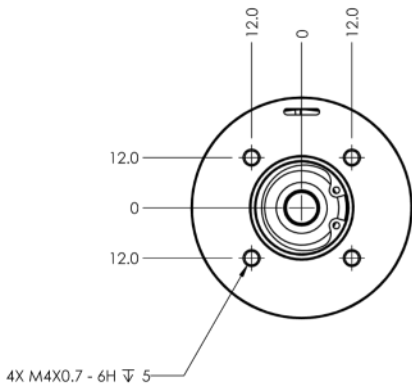

motor alone

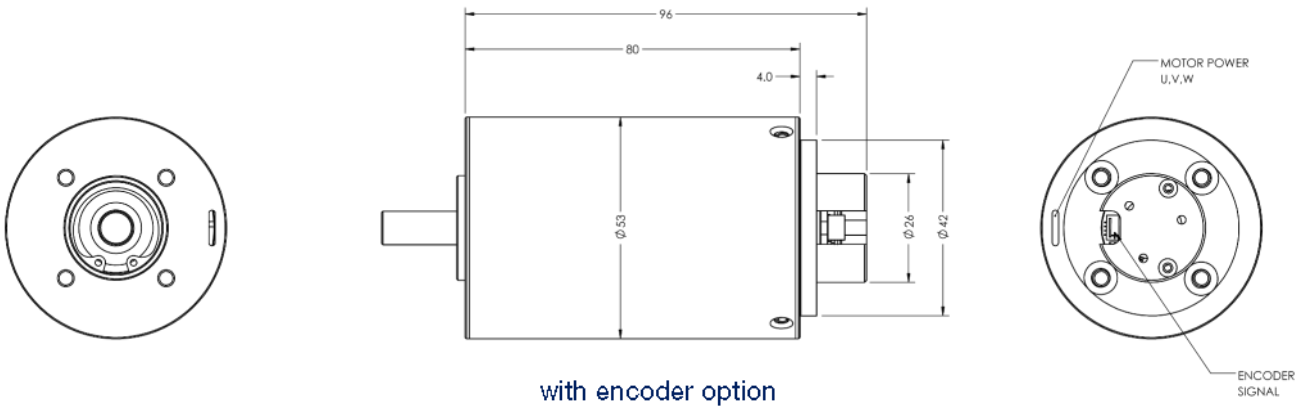

with encoder option

Operating Range (HT055)

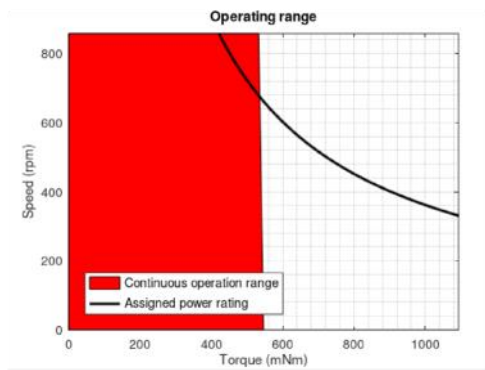

Speed, Torque, Efficiency Characteristics (HT055)

