

CBL35 Series

Electric Cylinder

Designed to overcome problems with existing conventional devices in the packaging industry with improved cycle rate, uptime, and work environment. For end users and machine manufacturers.

The CBL35 offers cycle life well beyond 100 million cycles. It achieves accelerations up to 50G, enabling the actuators to cycle at rate >2000 CPM. Fully programmable in force, position and velocity, it can be adjusted in seconds and does not require recalibration. Precise motion control has inherent force feedback capabilities. This results in a substantial saving of time and cost, and increases throughput due to a significant reduction in machine down time. Cleaner and quieter operation with no exhaust air.

SMAC

Moving Coil Actuators

CBL35 Series

Dimensions [mm]	Ø35 x 95 - 178 (depending on stroke)
Stroke [mm]	10, 15 & 25 +1/-0
Acceleration [G]	up to 50 (zero payload)
Peak Force [N]	up to 61
Encoder Resolution [µm]	5 standard, 1 optional
SMAC's Patented 'Soft-Land' Technology	
IP65 / IP67 protection available	



Applications

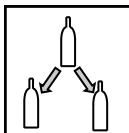

Sorting
Diverting

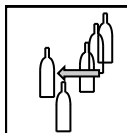

Rejecting

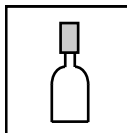

Nitrogen Dosing

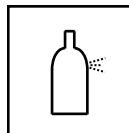

Leak Detection

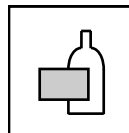

Labelling

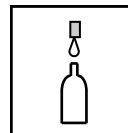

Filling

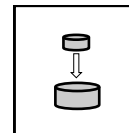

Assembly

PART NUMBERING

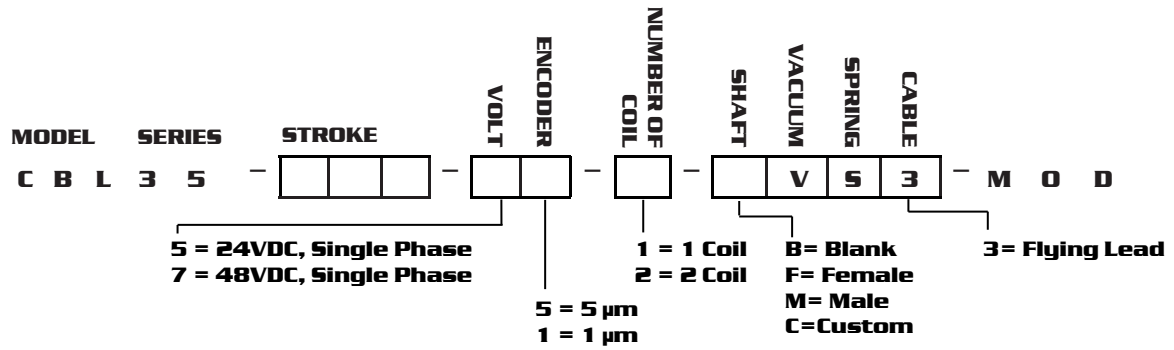

SPECIFICATION

Model	Voltage [DC]	Size: Dia. x L [mm]	Stroke [mm]	Peak Force [N]	Continuous Force [N]	Force Constant [N/A]	Max. Current [Amp]	Moving Mass [kg]	Weight [kg]
CBL35-010-55-1	24	Ø35x96	10	15	6	9	1.5	0.04	0.45
CBL35-010-75-1	48	Ø35x96	10	22	8.8	13.4	1.6	0.04	0.45
CBL35-010-75-3	48	Ø35x178	10	61	24.4	15	4.3	0.1	0.95
CBL35-015-55-1	24	Ø35x101	15	10	4	7	1.5	0.06	0.5
CBL35-025-55-1	24	Ø35x111	25	8.5	3.4	5.8	1.5	0.06	0.6
CBL35-025-75-1	48	Ø35x111	25	14	5.6	8.8	1.6	0.06	0.6

DIMENSIONS (CBL35 Series)

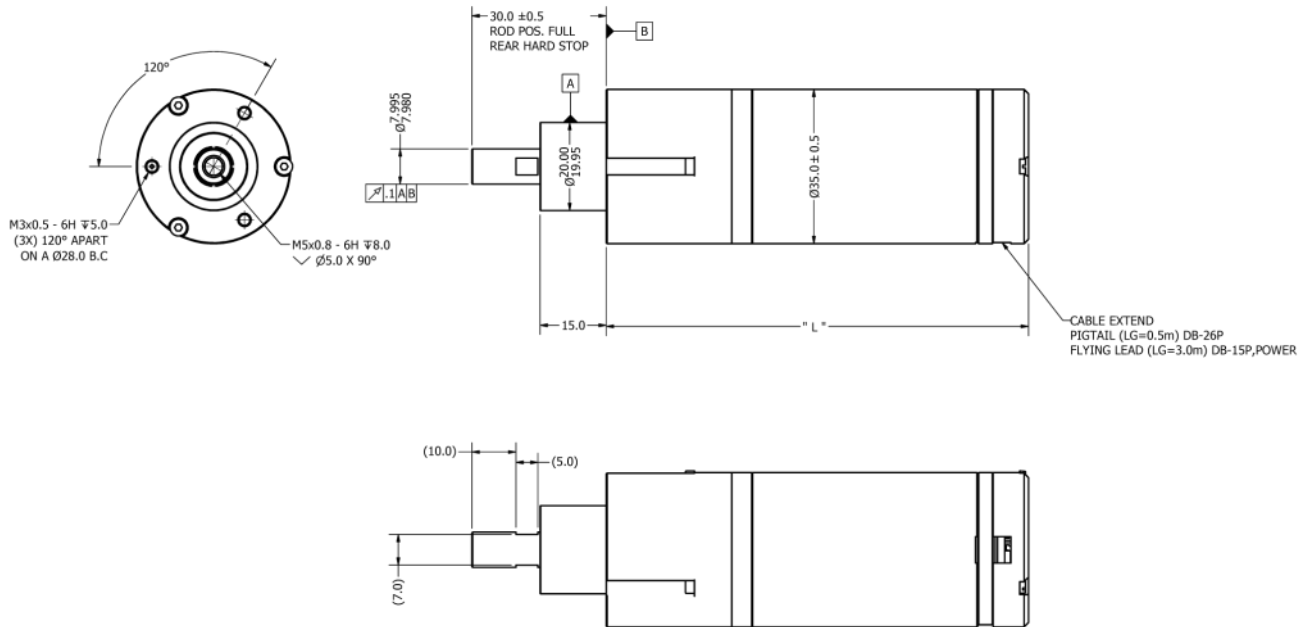

Regional Distributor



SMAC Headquarters
www.smac-mca.com
 5807 Van Allen Way, Carlsbad, CA 92008
 Tel: 760-929-7575 | Fax: 760-929-7588
 Email: info@smac-mca.com

CBL Series

Electric Cylinder with Built-in Controller

An electric cylinder with a built-in controller in a single, compact package for simple installation. The 35 mm diameter CBL35C and the 50 mm diameter CBL50C are available. Ideal for applications with limited space but requiring accurate control. The electric cylinders provide significantly longer life, programmability, high speed, accuracy, and energy efficiency while remaining price-competitive.

Graphical User Interface is available for the built-in controller for easy, straightforward setup of parameters. It allows you to change product profiles on the fly and improves factory uptime.

CBL35C & CBL50C Series

Dimensions [mm]:	Ø35 x 135 - 217, Ø50 x 177.5 - 255.5 (depending on stroke)
Stroke [mm]:	10, 15 & 25 +1/-0
Peak Force [N]:	8.5 - 100 (depending on model)
Encoder Resolution [µm]:	5 standard, 1 optional

Electric Cylinder with Built-in Controller
SMAC's Patented 'Soft-Land' Technology



Applications

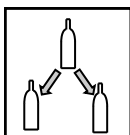

Sorting
Diverting

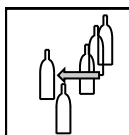

Rejecting

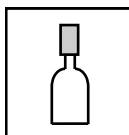

Nitrogen Dosing

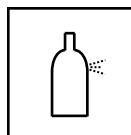

Leak Detection

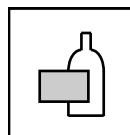

Labelling

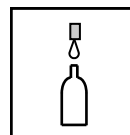

Filling

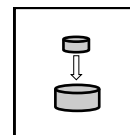

Assembly

PART NUMBERING

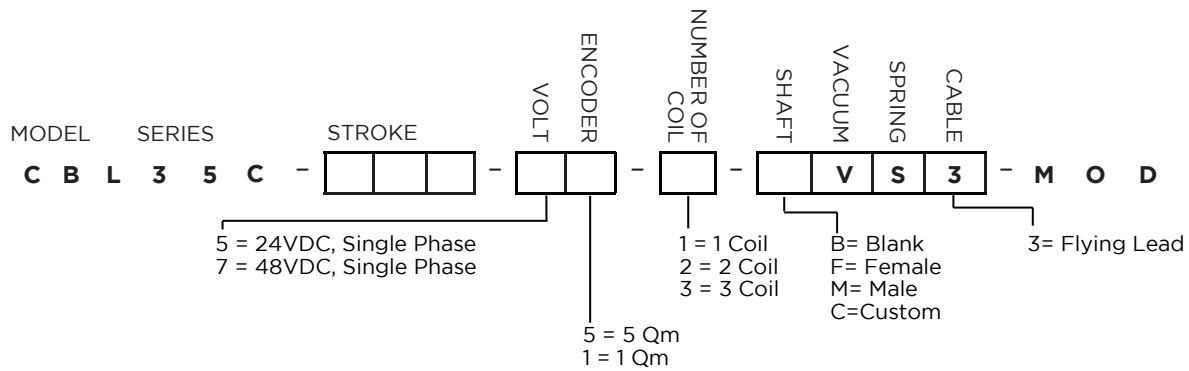

SPECIFICATION

Part Number	Voltage [DC]	Size: Dia.x L [mm]	Stroke [mm]	Peak Force [N]	Continuous Force [N]	Force Constance [N/A]	Maximum Current [Amp]	Moving Mass [kg]	Weight [kg]
CBL35C-010-55-1	24	Ø35x135	10	15	6	9	1.5	0.04	0.52
CBL35C-010-75-1	48	Ø35x135	10	22	8.8	13.4	1.6	0.04	0.52
CBL35C-015-55-1	24	Ø35x140	15	10	4	7	1.5	0.06	0.57
CBL35C-015-75-1	48	Ø35x140	15	14	5.6	8.8	1.6	0.06	0.57
CBL35C-025-55-1	24	Ø35x150	25	8.5	3.4	5.8	1.5	0.06	0.67
CBL35C-025-75-1	48	Ø35x150	25	14	5.6	8.8	1.6	0.06	0.67
CBL50C-010-55-1	24	Ø50x177.5	10	33	13	22	1.5	0.14	1.29
CBL50C-010-55-2	24	Ø50x220.5	10	49	19	16	3	0.21	1.8
CBL50C-010-75-1	48	Ø50x177.5	10	40	16	26	1.5	0.14	1.29
CBL50C-010-75-2	48	Ø50x220.5	10	100	40	33	3	0.21	1.8
CBL50C-025-55-1	24	Ø50x192.5	25	23	9	15	1.5	0.15	1.38
CBL50C-025-55-2	24	Ø50x256	25	40	16	13	3	0.24	2.25
CBL50C-025-75-1	48	Ø50x192.5	25	40	16	26	1.5	0.15	1.38
CBL50C-025-75-2	48	Ø50x255.5	25	70	28	23	3	0.24	2.25

CBC Built-in Controller Specification

1	Ambient operating temperature	0C to 70C (motor housing temp.)
2	LED display (GREEN)	Power on, Fault, Digital output
3	Communication interface	RS-232
4	2 PLC level, non-isolated digital input	Single end 24V level input, impedance 140k, 48V tolerant
5	2 Open drain digital output	500mA sink capacity
6	1 Analog input (single end)	0 -5V
7	Power supply input	8Vdc - 48Vdc
8	Encoder interface	TTL differential
9	Motor interface	Brush, and Brushless
10	Maximum peak phase current	4 A (rms) @ 1s
11	Maximum continuous phase current	1.5 A (rms)
12	Flash memory	1024Kb
13	Protection	Over temperature, over current, Overload, Reverse polarity connection

DIMENSIONS (CBL35C Series)

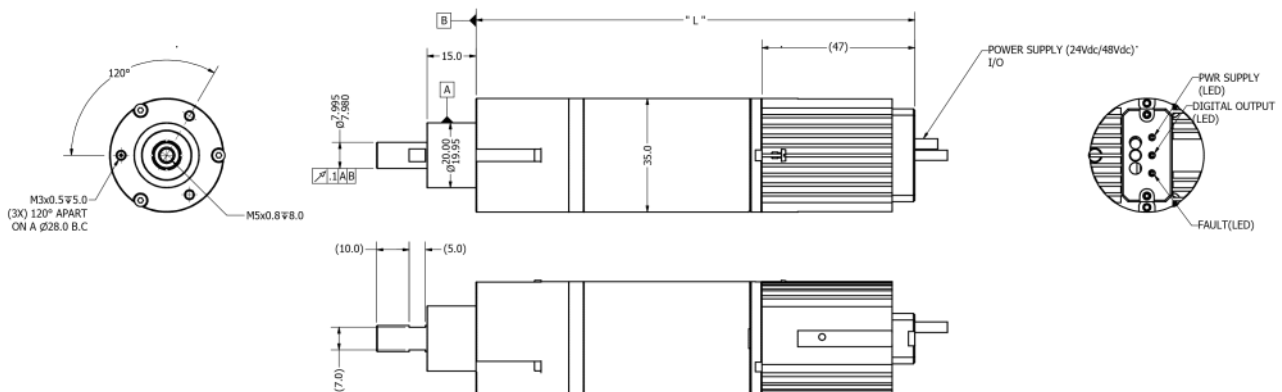

5807 Van Allen Way, Carlsbad, CA 92008
+1 760-929-7575 info@smac-mca.com