

# MSH SERIES — OPEN-TYPE MAGNETIC GRATING DISPLACEMENT SENSOR

*Passive gravity compensation — constant force, zero power consumption.*

The M-Spring magnetic spring gravity compensation system provides a steady, consistent holding force across its entire stroke using only magnetic force — no electricity, no external energy supply. Unlike conventional mechanical springs, M-Spring delivers truly constant thrust or tension regardless of position, from as low as 0.5 N up to 280 N. Its simple two-component design (stator and mover) offers an inherently safe, virtually maintenance-free solution for vertical axis applications. Custom force and stroke specifications are readily available.

## KEY FEATURES

- Simple structural design
- Constant force output over full stroke
- Standard force range: 0.5 N to 280 N
- Force accuracy:  $\pm 5\%$  or  $\pm 3\%$  selectable
- No external energy supply required — high safety factor
- Flexible mounting: double-end fixed or single-end fixed
- Custom specifications available on request



## BACKGROUND

When linear motors are used vertically, an external holding device is required. Unlike conventional mechanical springs, the M-Spring magnetic spring can provide a constant push or pull force across the entire stroke. The M-Spring series uses an innovative magnetic circuit design to compensate for and cancel gravity purely through the magnetic field — completely passive, requiring no power supply. The assembly consists of only two components: a stator and a mover.

M-Spring is the ideal choice for applications requiring high safety factors, constant thrust or tension, gravity compensation, and vertical holding. It is widely applicable in aerospace and defence, medical devices, industrial automation, automotive, machine tools, CNC systems, and vibration isolation systems.

## part number structure & ordering information

**SP 10 - 20 - 12N - D - C**

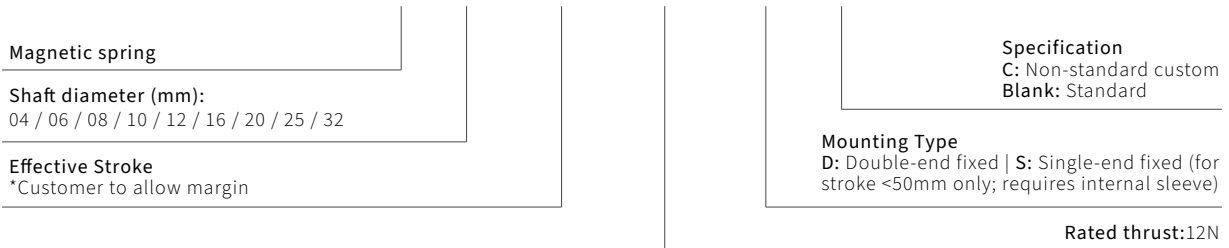

## STANDARD PRODUCT MODEL SPECIFICATIONS

Model	Force Range (N)	Max Stroke (mm)	Accuracy	Shaft OD (mm)	Outer OD (mm)	Min Clearance (mm)
SP04	0.5–1.8	15	±3% or ±5%	4	8	0.5
SP06	1.8–5	45	±3% or ±5%	6	11	0.5
SP08	5–10	75	±3% or ±5%	8	13	0.5
SP10	10–16	120	±3% or ±5%	10	15	0.5
SP12	16–29	120	±3% or ±5%	12	18	0.5
SP16	29–44	150	±3% or ±5%	16	23	0.5
SP20	44–65	200	±3% or ±5%	20	27	0.5
SP25	69–96	300	±3% or ±5%	25	33	0.5
SP32	96–150	300	±3% or ±5%	32	40	0.5
SP45	150–280	300	±3% or ±5%	45	56	0.5

### SP04-7-1N-S Magnetic Spring Dimensions

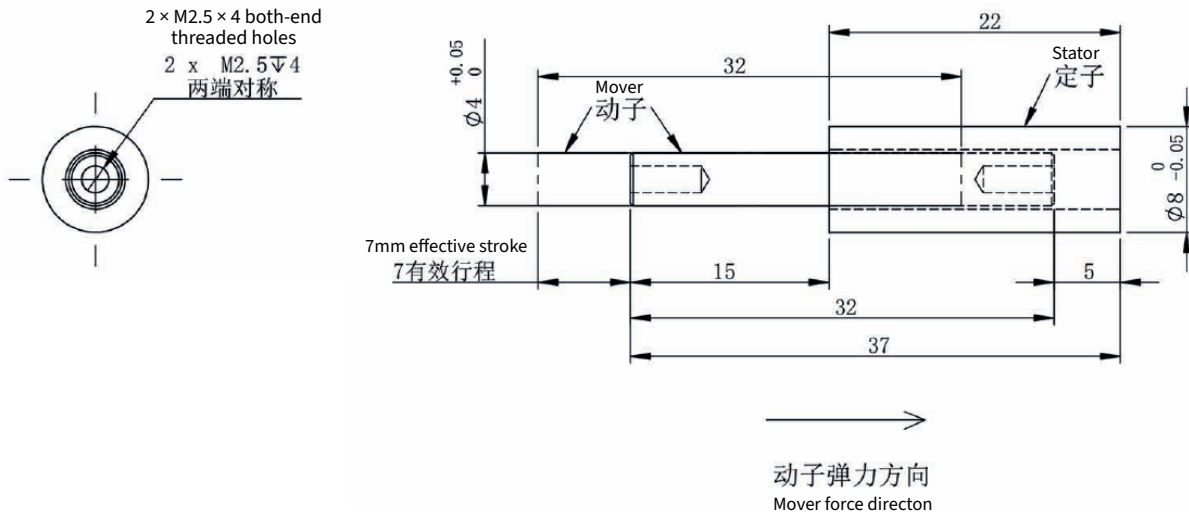

### SP06-40-4N-S Magnetic Spring Dimensions

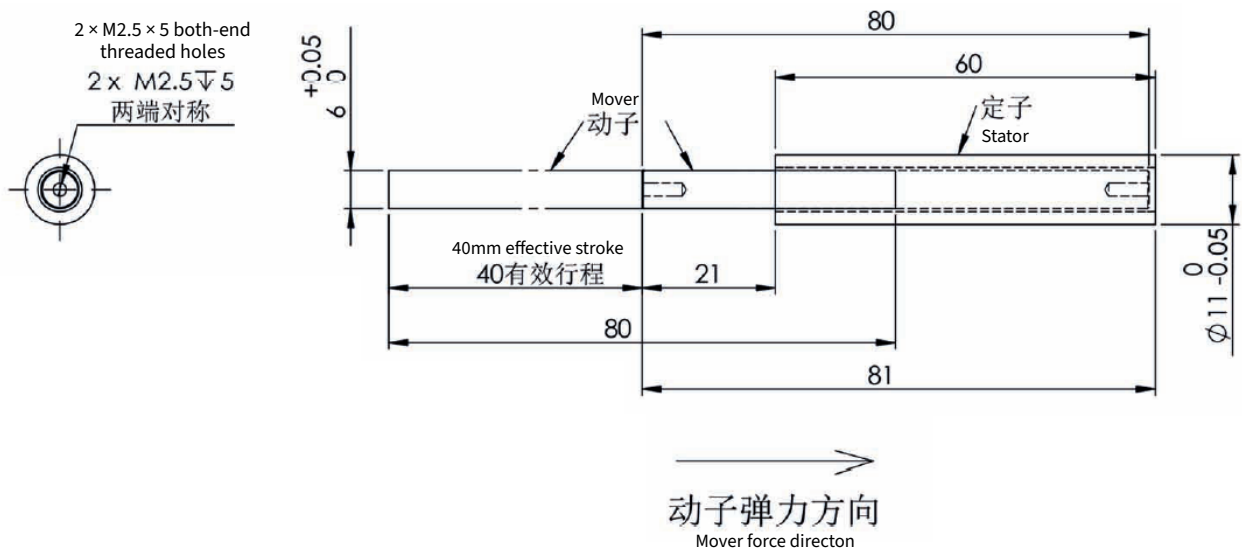

## SP08-30-6N Magnetic Spring Dimensions

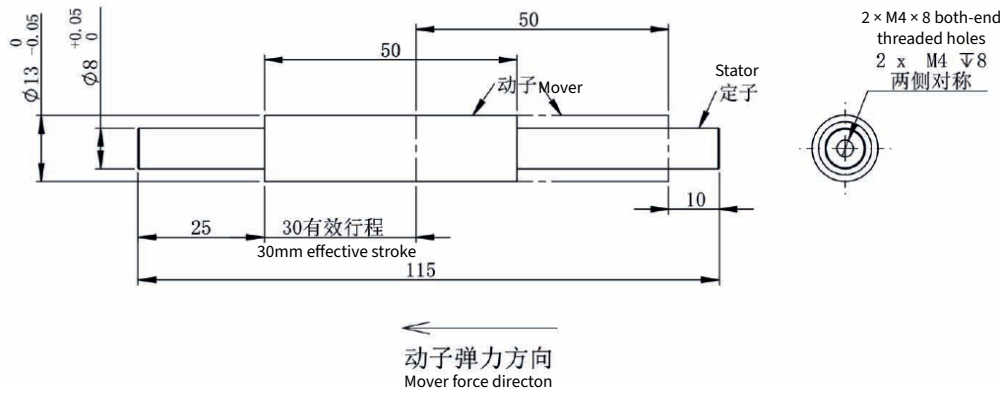

## SP10-40-10N-S Magnetic Spring Dimensions

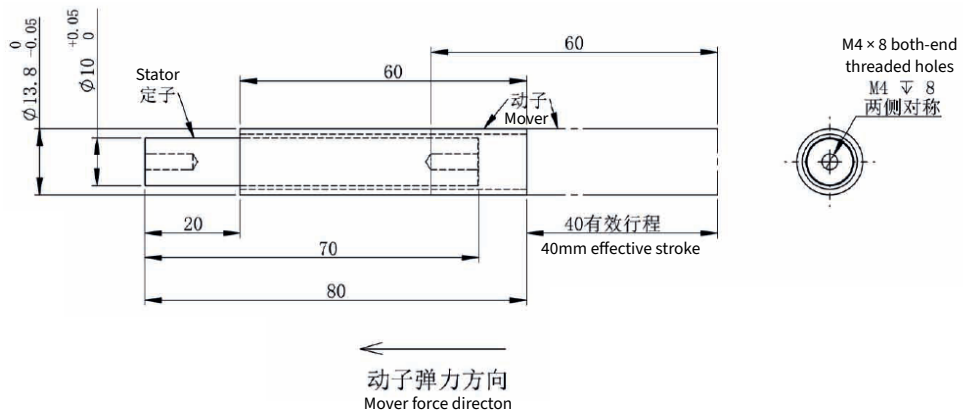

## SP12-50-20N Magnetic Spring Dimensions

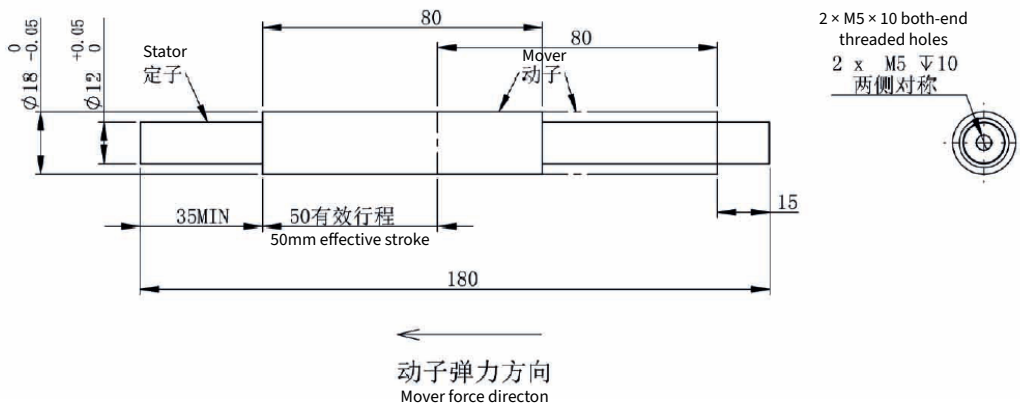

## SP16-50-37N Magnetic Spring Dimensions

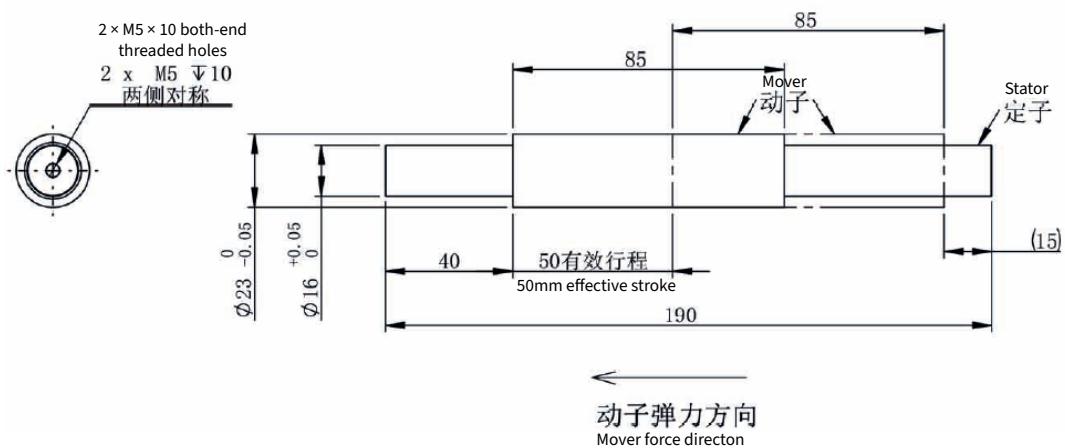

## SP20-55-50N Magnetic Spring Dimensions

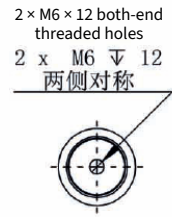
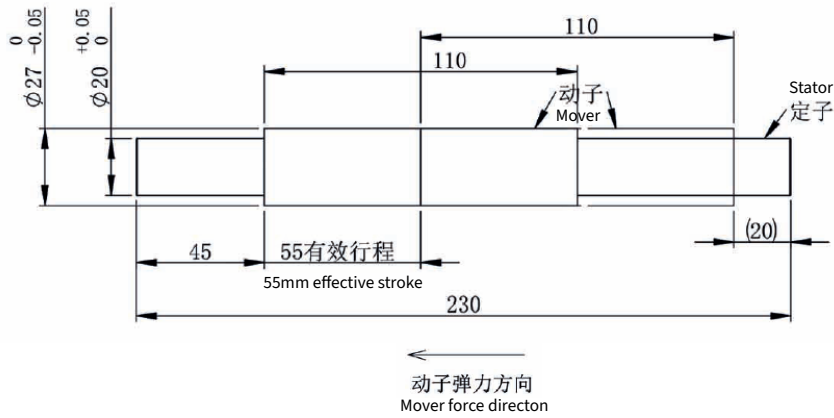

## SP25-65-75N Magnetic Spring Dimensions

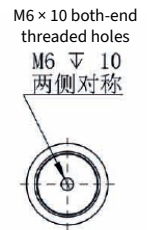
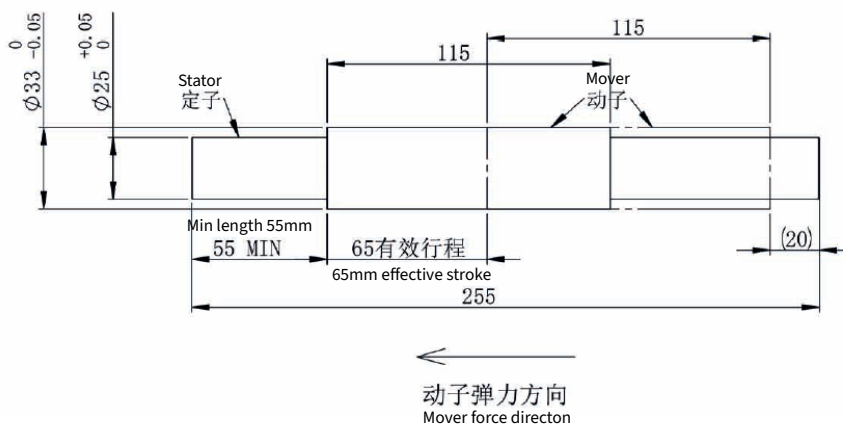

## SP32-130-110N Magnetic Spring Dimensions

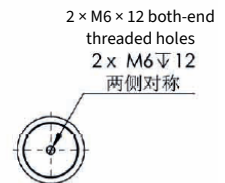
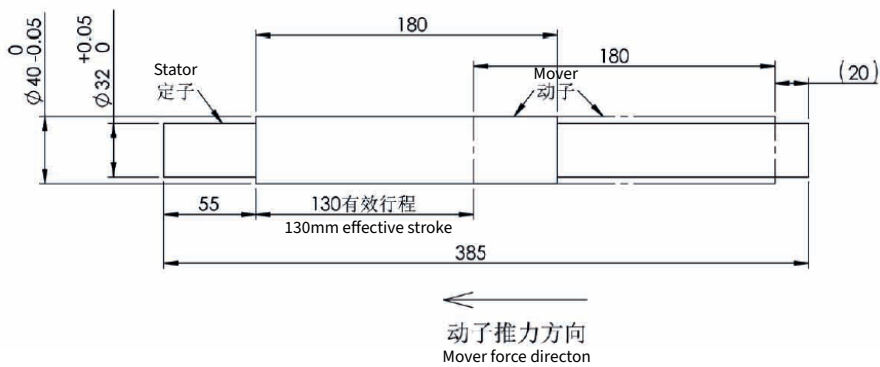

## SP45-130-200N Magnetic Spring Dimensions

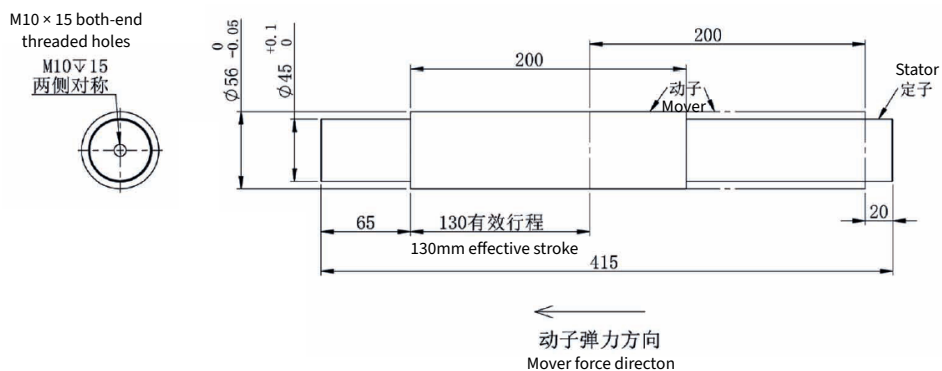

M10 x 15 both-end threaded holes  
M10  $\nabla$  15  
两侧对称



动子弹力方向  
Mover force direction

## HOW TO ORDER A CUSTOM MAGNETIC SPRING

We can professionally customise constant-force magnetic springs to any specification. Thanks to our in-house design and manufacturing capabilities, lead times for Inoservo custom springs are comparable to standard product lead times. Custom springs are straightforward for us to produce — as our customers can confirm.

We work with customers at every stage, from prototype through to mass production. Customers will need experienced engineers with expertise in magnetic spring simulation and design. Since force requirements vary by application, we encourage you to contact us — our engineers will provide professional assistance.

We can offer technical support during the product design phase and provide quotations for custom magnetic springs in any quantity.

**Note:** *For applications where the magnetic spring pushes upward, please confirm the configuration with our engineers and provide drawings before proceeding.*