







SHAFT SUPPORTER AND SHAFT SUPPORT RAIL

These components save design/assembling time and ease shaft installation.

<p><b>SH·SH-A·WH-A type</b></p> <p>These are most commonly used compact shaft supporters. SH type is made of cast iron and SH-A/WH-A type is made of aluminum casting.</p>	<p>SH-A type</p>  <p>P.F-11</p>
	<p>SH type</p>  <p>P.F-12</p>
	<p>WH-A type</p>  <p>P.F-16</p>
<p><b>SHF·SHF-FC type</b></p> <p>These are flanged type shaft supporters for a compact design. SHF is made of aluminum casting and SHF-FC (shaft diameter 35 and over) is made of cast iron.</p>	<p>SHF type SHF-FC type</p>  <p>P.F-13</p>
	<p>SA type</p>  <p>P.F-14</p>
<p><b>SA·WA·LWA type (shaft support rail)</b></p> <p>These support rails support shafts from below to avoid shaft deflection for a long-stroke/high load application. This type is made of aluminum alloy.</p>	<p>WA type</p>  <p>P.F-18</p>
	<p>LWA type</p>  <p>P.F-19</p>

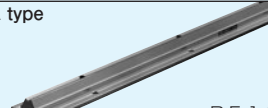
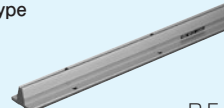
ACCURACY OF SA TYPE SUPPORT RAIL

The accuracy of the SA support rails are measured as shown in Figure F-1.

Figure F-1 Measurement Method

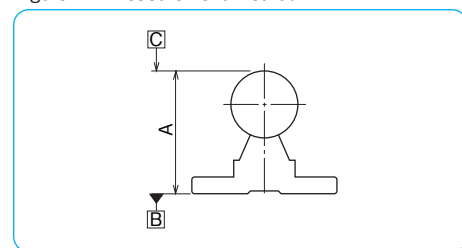
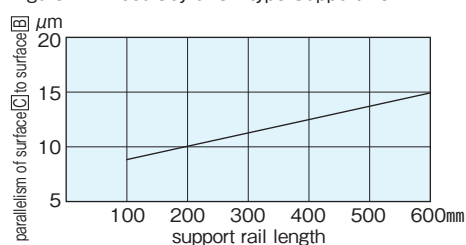
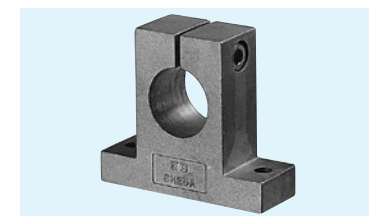

Figure F-2 Accuracy of SA type Support Rail



SH-A TYPE

– Shaft Supporter –



part number structure

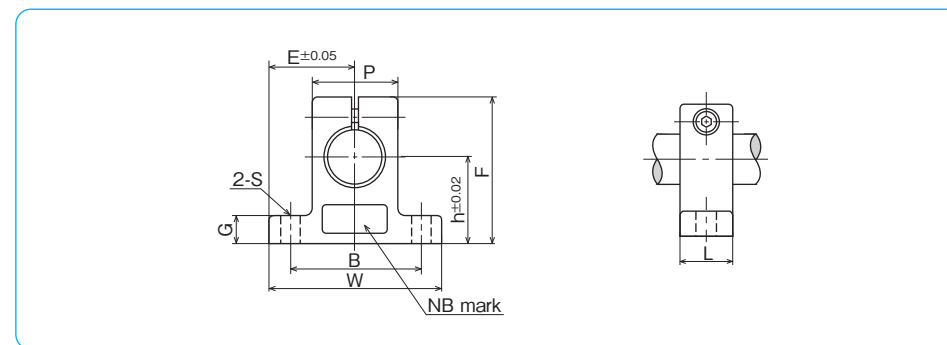
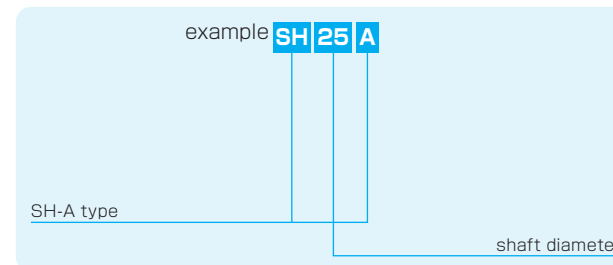

part number	shaft diameter mm	major dimensions									tightening screw size	recommended torque N·m	mass g
		h mm	E mm	W mm	L mm	F mm	G mm	P mm	B mm	S mm			
SH 8A	8	20	21	42	14	32.8	6	18	32	5.5 (M5)	M4	2	24
SH10A	10	20	21	42	14	32.8	6	18	32	5.5 (M5)	M4	2	24
SH12A	12	23	21	42	14	37.5	6	20	32	5.5 (M5)	M4	2	30
SH13A	13	23	21	42	14	37.5	6	20	32	5.5 (M5)	M4	2	30
SH16A	16	27	24	48	16	44	8	25	38	5.5 (M5)	M4	2	40
SH20A	20	31	30	60	20	51	10	30	45	6.6 (M6)	M5	3	70
SH25A	25	35	35	70	24	60	12	38	56	6.6 (M6)	M6	5.5	130
SH30A	30	42	42	84	28	70	12	44	64	9 (M8)	M6	5.5	180
SH35A	35	50	49	98	32	82	15	50	74	11 (M10)	M8	13.5	270
SH40A	40	60	57	114	36	96	15	60	90	11 (M10)	M8	13.5	420
SH50A	50	70	63	126	40	120	18	74	100	14 (M12)	M12	29	750
SH60A	60	80	74	148	45	136	18	90	120	14 (M12)	M12	29	1,100