

# UNIMOTION

LMCA

LINEAR MOTORS



GERMAN  
DESIGN  
AWARD  
WINNER  
2022

CE

✓RoHS

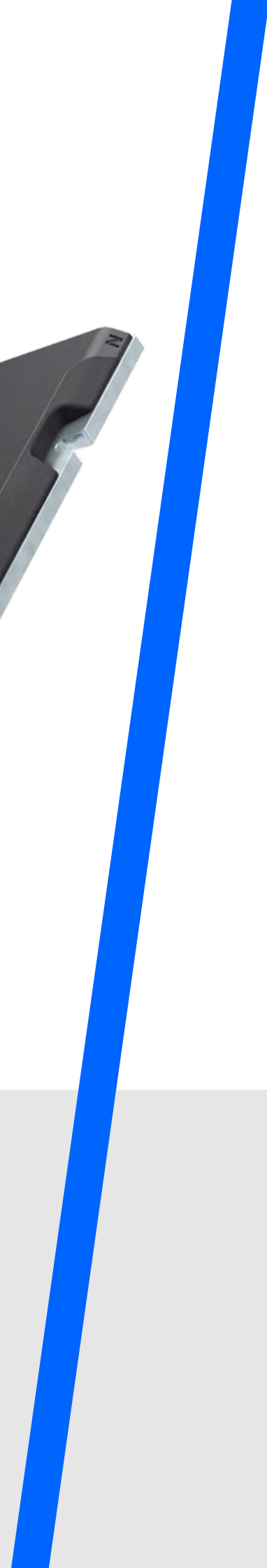

# About Us

UNIMOTION is a leading company in the industrial automation field, at a global level. Combining innovative engineering solutions – Unimotion helps companies of all sizes across a wide range of industrial segments. Unimotion develops Industry 4.0-enabled products and systems with leading quality, performance and value. Engineering, Production, Construction, Warehouse, Research & Development department; all this can be found under one roof. Thanks to years of experience and a consistent focus on automation technology, we are continually improving our products and implementing innovations that provide customers with many technical advantages. Our core values are precision, innovation, passion, and integrity. At Unimotion, our main goal is the satisfaction of every single customer with a commitment to deliver the impossible.

Unimotion sales team, technicians and experts are at your disposal to provide customized expertise and support. We look forward to meeting you and work on your special project.



# Table of Contents

<b>Product overview</b>	4
<b>Basic description</b>	6
Structural design .....	8
Terms explanation .....	9
<b>How to order</b>	10
<b>Characteristics</b>	12
LMCA 30 .....	13
LMCA 60 .....	16
LMCA 90 .....	19
Mounting tolerances .....	22
Electrical data .....	23
<b>LMCA Hall sensor</b>	26
<b>Motor selection example</b>	29

## **Product overview**

## PRODUCT OVERVIEW

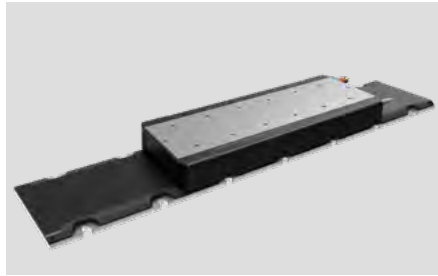

LMCA 30 is our smallest design in the LMCA family. In the picture LMCA 30 S is presented. It is also available in M and L versions.

They offer a superb ratio between maximum velocity and the mass of the forcer, therefore they are suitable for applications with light payloads, where high speeds and accelerations are required.

LMCA 60 represents the middle section of the LMCA family. In the picture LMCA 60 M is presented. It is also available in S, L and XL versions.

Because of their mid-range design, they offer high dynamics and a great speed-to-force ratio.

LMCA 90 is our strongest design in the LMCA family. In the picture LMCA 90 XL is presented. It is also available in S, M and L versions.

They are primarily used in applications where axial force demands are the highest.

## POWER RANGE

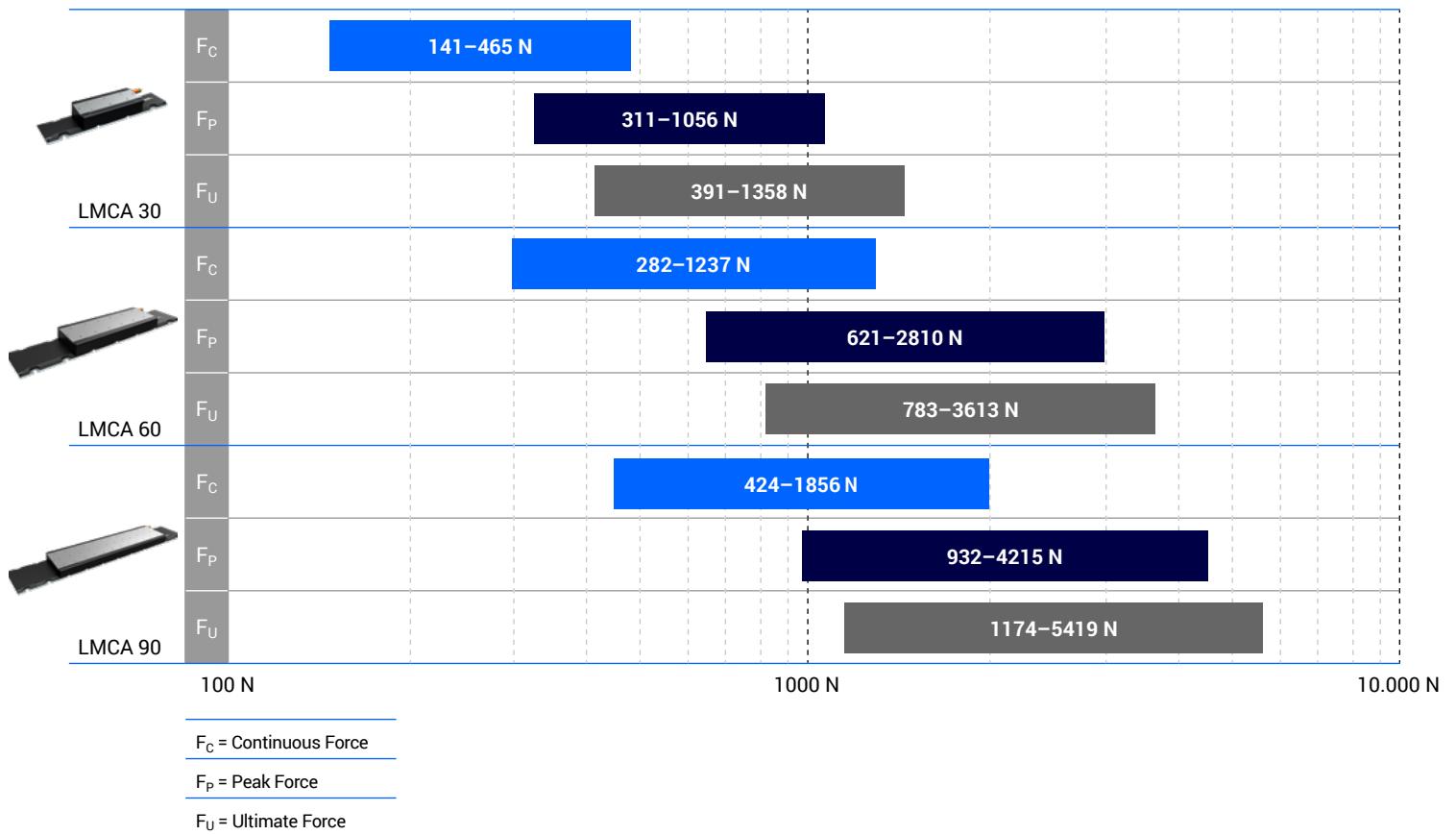

# Basic description

Structural design .....	8
Terms explanation .....	9

Linear motors are an ideal substitute for pneumatic, hydraulic, belt, ball screw, or other types of drives. Linear motor drive systems do not require conversion from rotational to linear movement, because the movement is generated directly from the linear electromagnetic force. The linear motor driven systems in comparison with the traditional linear units are more compact, accurate, repeatable, faster, robust, reliable, generate less noise and after all, require no maintenance. Linear motors are also known as “direct-drive” motors because the load is directly coupled onto them.

- UNIMOTION linear motors are ideal for a variety of applications, ie.: actuators, robots, XYZ tables, positioning, assembly, tool machines, P&P machines, fiber optic machines, and many others. The main advantage of UNIMOTION linear motors is force density, which is 30–50 % higher compared to other competitors on the market, while still retaining a very low cogging force. Thanks to our innovative design and state-of-the-art materials, we can offer our customers the industry-leading linear motor on the market for a competitive price.

Besides different motor sizes (30, 60, 90) and versions (S, M, L and XL), we offer two types of magnet plates that are compatible with all the motors:

- A classic magnet plate, that enables continuous forces from 141 N to 1665 N (peak from 311 N to 3661 N), and
- Our innovative high-performance magnet plate design, which results in much higher force density and also boosts the continuous (from 158 N to 1856 N) and peak forces (from 358 N to 4215 N), which is nearly 11 % higher in comparison with the classic magnet plate.

Additionally, for each motor size, we are offering two speed types:

- A low-speed variant, and
- A high-speed variant, which has a lower BEMF constant and is suitable for applications, requiring higher speed or low supply voltage.

Both solutions are air-cooled with an extremely high force density, which offers a small and very compact design of the linear motion systems and units.

In order to allow an easy drive integration, we designed our own Hall module which features analog as well as a digital Hall sensor in only one housing.

**i** For more information regarding the Hall sensor, please refer to page 27–28.

All UNIMOTION LMCA linear motor are CE and RoHS compliant.



## STRUCTURAL DESIGN

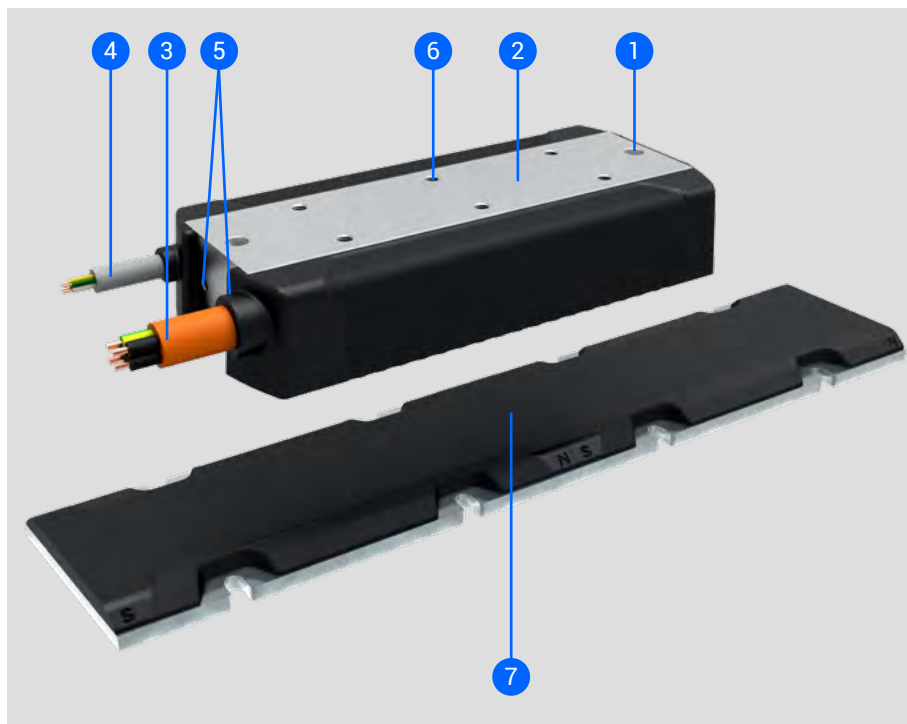

- 1 – Hole for the centering ring
- 2 – Forcer body
- 3 – Power cable
- 4 – Signal cable
- 5 – Hall sensor mounting holes
- 6 – Mounting holes
- 7 – Magnet plate

**i** For more information regarding the Hall sensor, please refer to page 27–28.

## TERMS EXPLANATION

### Supply voltage $V_{DC}$ :

A maximum allowed supply voltage, that can be applied to the motor windings.

### Continuous force $F_C$ :

Force produced by the continuous current ( $I_C$ ) at an ambient temperature of 20 °C and continuous movement of the motor. The windings temperature depends on the attached plate (heatsink) heat dissipation and airflow around the motor.

### Peak force $F_P$ :

Force produced by the peak current ( $I_P$ ) for a duration of 1 second. The force is used for acceleration or deceleration.

### Ultimate force $F_U$ :

Force produced by the ultimate current ( $I_U$ ) for a duration of 0,5 seconds. The force is used for acceleration or deceleration.

### Attraction force of magnets $F_A$ :

Attraction force between the forcer and the magnet plate at the defined air gap.

### Cogging (detent) force $F_G$ :

Force generated due to the interaction between the permanent magnets of the magnet plate and the mover slots. The cogging force is permanently present and is position-dependent.

### Force constant $K_F$ :

Defines how much force is produced per unit of current. It is the ratio of the force to the motor phase current.

### Motor constant $K_M$ :

The ratio of the motor force and square root of the power loss at 20 °C. The constant determines the motor's efficiency.

### Back EMF phase-phase constant $K_{BEMF}$ :

Defines the phase-to-phase voltage generated when the motor is moving at 1 m/s at the magnet temperature of 20 °C.

### Continuous current $I_C$ :

It corresponds to the continuous force ( $F_C$ ) and can be continuously applied to the motor at the ambient temperature of 20 °C and continuous movement of the motor. The windings temperature depends on the attached plate (heatsink) heat dissipation and airflow around the motor.

### Peak current $I_P$ :

Corresponds to the peak force ( $F_P$ ) and can be applied to the motor for 1 second.

### Ultimate current $I_U$ :

Corresponds to the ultimate force ( $F_U$ ) and can be applied to the motor for 0,5 seconds.

### Resistance phase-phase $R_{20}$ :

Motor windings resistance measured phase to phase (line to line) at 20 °C.

### Resistance phase-phase $R_{125}$ :

Motor windings resistance measured phase to phase (line to line) at 125 °C.

### Induction phase-phase $L_P$ :

Motor windings inductance measured phase-to-phase (line-to-line).

### Electrical time constant $t_C$ :

The electrical time constant is the amount of time it takes for the current in the motor windings to reach 63 % of its rated value. The time constant is found by dividing inductance by resistance.

### Max. winding temperature $T_{max}$ :

Defined as a maximum permissible temperature of the motor windings. During the normal operation, it is recommended that windings temperature does not exceed 80 % of  $T_{max}$ .

### Thermal resistance $R_{th}$ :

Defines the heat transfer resistance from the motor windings to the environment at the defined plate (heatsink) and air dissipation.

### Thermal resistance to heatsink $R_{th-HS}$ :

Defines the heat transfer resistance from the motor windings to the heatsink attached surface.

### Magnet pitch $\tau$ :

Magnet pitch or pole pair length is the distance between two same polar magnets on the magnet plate.

### Thermal time constant $\tau_{th}$ :

Defined as a time required for the winding to reach 63 % of the max. temperature at continuous current. This value is only applicable when the mounting surface is at the constant temperature.

**i** Described parameters were measured with an air gap of 0,6 mm.

Continuous and attraction force as a function of an air gap

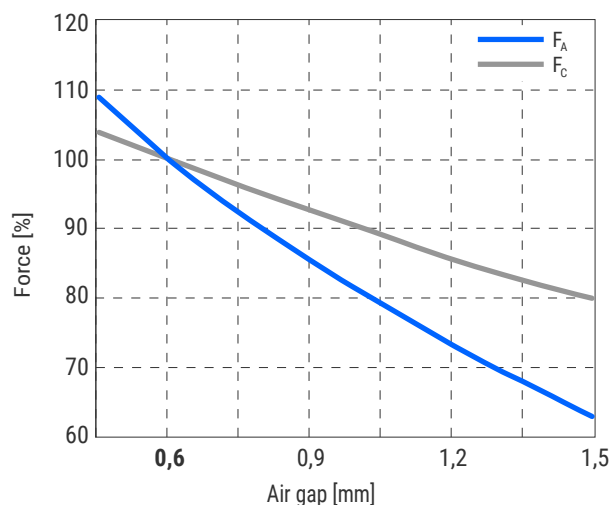

**i** The air gap of 0,6 mm provides an optimal continuous-to-attraction force ratio. Increasing the air gap will result in a lower attraction force, lower cogging and lower useful force.

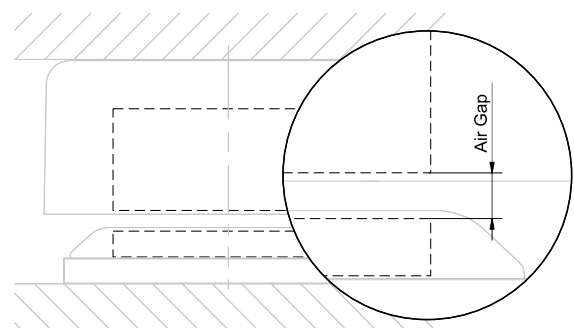

**i** An actual air gap between the magnet plate and coil unit is difficult to measure because of the casted finish. For an accurate measurement, the air gap can be calculated from the total mounting height.

**How to order**

## HOW TO ORDER

Forcer order code:

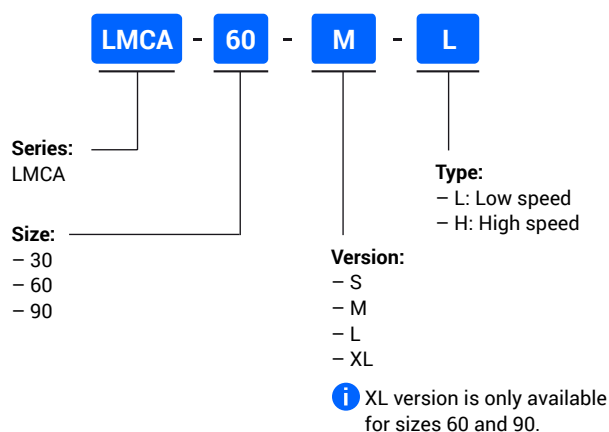

Magnet plate order code:

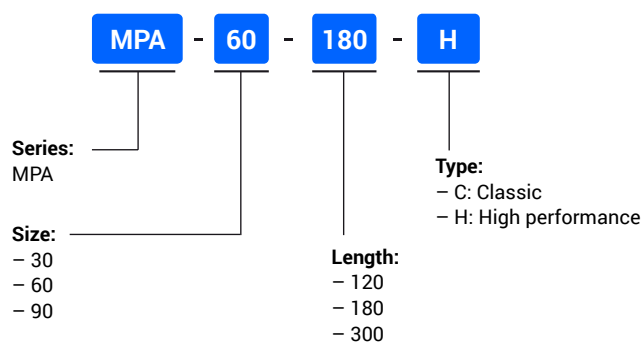

# UNIMOTION

## CALCULATE AND CONFIGURE YOUR OWN SOLUTION

The LINEAR MOTOR CALCULATION TOOL is an online application that enables quick and easy selection of a suitable product, with the possibility of achieving the optimal ratio between the given capacity and the price and the creation of the 3D models.

For more information please contact us or visit our website.

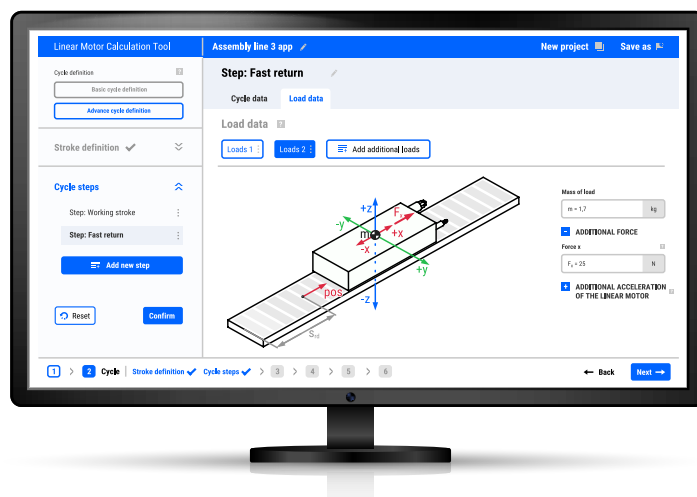

# Characteristics

LMCA 30 .....	13
LMCA 60 .....	16
LMCA 90 .....	19
Mounting tolerances .....	22
Electrical data .....	23

## LMCA 30

### General technical data

				LMCA 30											
				Version S				Version M				Version L			
				Classic		High performance		Classic		High performance		Classic		High performance	
PARAMETER	SYM	UNIT	Low speed	High speed	Low speed	High speed	Low speed	High speed	Low speed	High speed	Low speed	High speed	Low speed	High speed	
PERFORMANCE	Max. supply voltage	V <sub>DC</sub>	V (DC) 600												
	Continuous force <sup>1</sup>	F <sub>C</sub>	141		158		279		311		417		465		
	Peak force (1s) <sup>1</sup>	F <sub>P</sub>	311		358		614		707		917		1056		
	Ultimate force (0,5s) <sup>1</sup>	F <sub>U</sub>	391		460		773		909		1155		1358		
	Attraction force of magnets <sup>2</sup>	F <sub>A</sub>	678		958		1245		1759		1812		2560		
	Force constant	K <sub>F</sub>	$\frac{N}{A_{RMS}}$	47,0	20,5	52,7	23,0	46,5	20,4	51,8	22,7	46,3	20,2	51,7	22,6
	Motor constant	K <sub>M</sub>	$\frac{N}{\sqrt{W}}$	17,2	17,2	19,3	19,3	24,1	24,0	26,8	26,8	29,4	29,2	32,7	32,6
	Back EMF phase-phase constant	K <sub>BEMF</sub>	$\frac{V_{RMS}}{m/s}$	27,2	11,9	31,4	13,7	26,9	11,7	31,0	13,5	26,7	11,7	30,9	13,5
ELECTRICAL	Continuous current	I <sub>C</sub>	A <sub>RMS</sub>	3,0	6,9	3,0	6,9	6,0	13,7	6,0	13,7	9,0	20,6	9,0	20,6
	Peak current	I <sub>P</sub>	A <sub>RMS</sub>	9,0	20,6	9,0	20,6	18,0	41,2	18,0	41,2	27,0	61,8	27,0	61,8
	Ultimate current	I <sub>U</sub>	A <sub>RMS</sub>	15,0	34,3	15,0	34,3	30,0	68,7	30,0	68,7	45,0	103,0	45,0	103,0
	Resistance at 20 °C phase-phase	R <sub>20</sub>	Ω	4,99	0,95	4,99	0,95	2,49	0,48	2,49	0,48	1,66	0,32	1,66	0,32
	Resistance at 125 °C phase-phase	R <sub>125</sub>	Ω	7,05	1,34	7,05	1,34	3,52	0,68	3,52	0,68	2,34	0,45	2,34	0,45
	Induction phase-phase	L <sub>P</sub>	mH	28,2	5,4	28,2	5,4	14,1	2,7	14,1	2,7	9,4	1,8	9,4	1,8
	Electrical time constant <sup>3</sup>	t <sub>C</sub>	mS	5,7	5,7	5,7	5,7	5,7	5,6	5,7	5,6	5,7	5,6	5,7	5,6
THERMAL	Max. winding temperature	T <sub>max</sub>	°C 125												
	Max. allowed magnet plate temperature	T <sub>magnet</sub>	°C 90												
	Thermal time constant	τ <sub>th</sub>	s 69												
	Thermal resistance	R <sub>th</sub>	$\frac{K}{W}$	1,10				0,55				0,37			
	Thermal resistance to heatsink	R <sub>th_HS</sub>	$\frac{K}{W}$	0,250				0,125				0,083			
MECHANICAL	Forcer overall length	M <sub>L</sub>	mm 128												
	Forcer overall width	M <sub>W</sub>	mm 56												
	Forcer overall height	M <sub>H</sub>	mm 23,5												
	Forcer mass	m <sub>m</sub>	0,8				1,5				2,2				
	Magnet plate weight	m <sub>S</sub>	$\frac{kg}{m}$	2,4		2,6		2,4		2,6		2,4		2,6	
	Forcer wires cross-section	S <sub>C</sub>	mm <sup>2</sup> 1,5												
	Sensor wires cross-section	S <sub>SC</sub>	mm <sup>2</sup> 0,25												
	Forcer cable length	L <sub>M</sub>	mm 1000												
	Sensor cable length	L <sub>S</sub>	mm 1000												
	Magnet pitch	τ	mm 30												

<sup>1</sup> Magnets at 20 °C

<sup>2</sup> RMS at 0 A and air gap of 0,6 mm

<sup>3</sup> Windings at 20 °C

**i** The specifications were measured without forced cooling. Electrical specifications tolerance is ± 10 %.

Force as a function of velocity diagrams

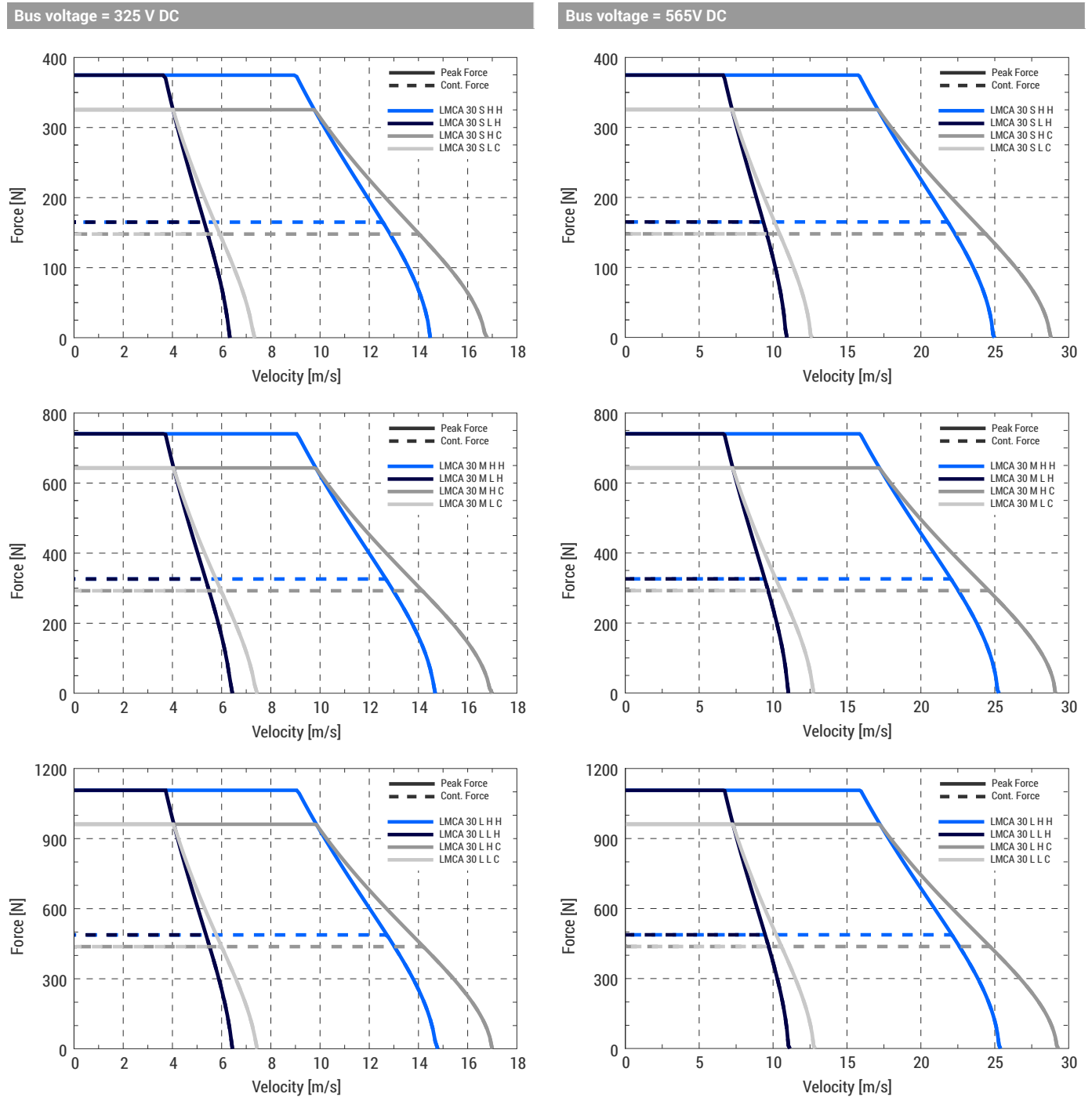

### Forcer dimensions

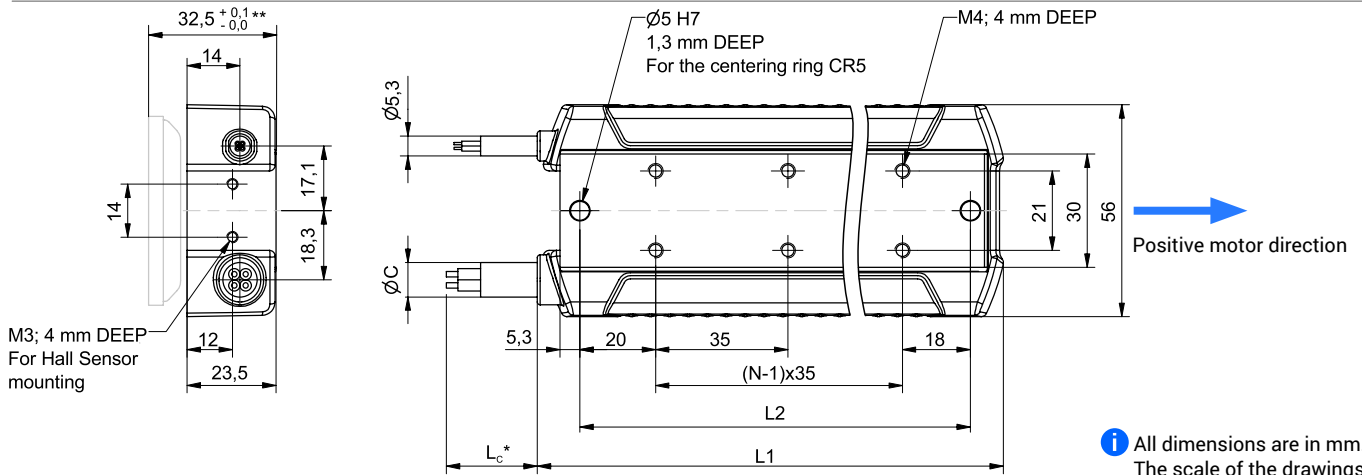

\* Standard cable length  
 \*\* The stated mounting height is set for the air gap of 0,6 mm. For more information, please refer to page 9.

**i** All dimensions are in mm. The scale of the drawings may not be equal.

LMCA 30	L1 [mm]	L2 ± 0,02 [mm]	N	∅C	Lc [mm]
LMCA 30 S H/L	128	108	3	9,1	1000
LMCA 30 M H/L	233	213	6	9,1	1000
LMCA 30 L L	338	318	9	9,1	1000
LMCA 30 L H	338	318	9	10,6	1000

**i** 'N' is the number of mounting holes in the x-direction.

### Magnet plate dimensions

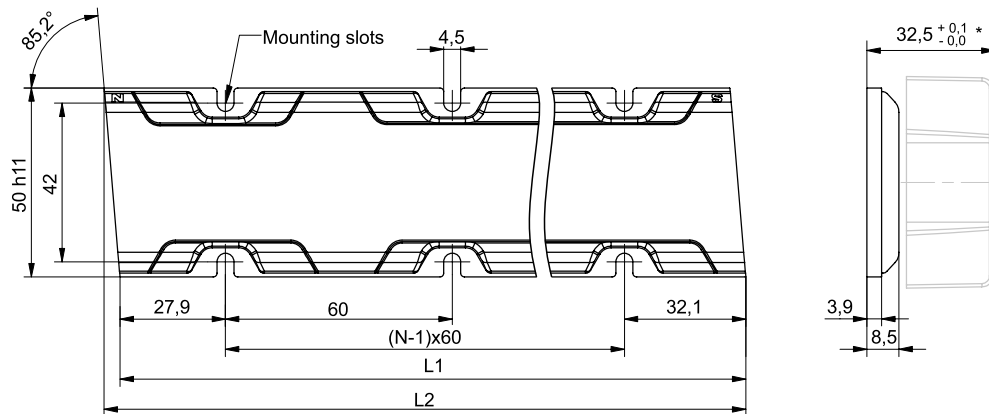

\* The stated mounting height is set for the air gap of 0,6 mm. For more information, please refer to page 9.

MPA 30	L1 [mm]	L2 [mm]	N
MPA 30 120 C/H	120	124,2	2
MPA 30 180 C/H	180	184,2	3
MPA 30 300 C/H	300	304,2	5

**i** 'N' is the number of mounting slots in the x-direction.

## LMCA 60

### General technical data

			LMCA 60																
			Version S				Version M				Version L				Version XL				
			Classic		High performance		Classic		High performance		Classic		High performance		Classic		High performance		
PARAMETER	SYM	UNIT	Low speed	High speed	Low speed	High speed	Low speed	High speed	Low speed	High speed	Low speed	High speed	Low speed	High speed	Low speed	High speed	Low speed	High speed	
PERFORMANCE	Max. supply voltage	V <sub>DC</sub>	V (DC) 600																
	Continuous force <sup>1</sup>	F <sub>C</sub>	282		315		558		622		834		930		1110		1237		
	Peak force (1s) <sup>1</sup>	F <sub>P</sub>	621		715		1228		1414		1834		2112		2441		2810		
	Ultimate force (0,5s) <sup>1</sup>	F <sub>U</sub>	783		920		1547		1818		2310		2715		3074		3613		
	Attraction force of magnets <sup>2</sup>	F <sub>A</sub>	1356		1916		2490		3518		3624		5120		4758		6722		
	Force constant	K <sub>F</sub>	$\frac{N}{A_{RMS}}$	94,0	41,0	105,0	45,9	93,0	40,6	103,7	45,3	92,7	40,5	103,3	45,1	92,5	40,4	103,1	45,0
	Motor constant	K <sub>M</sub>	$\frac{N}{\sqrt{W}}$	27,0	26,9	30,1	30,1	37,7	37,8	42,0	42,1	46,0	45,8	51,3	51,1	53,0	52,8	59,1	58,8
	Back EMF phase-phase Constant	K <sub>BEMF</sub>	$\frac{V}{(m/s)}$	54,4	23,7	62,8	27,4	53,7	23,5	62,0	27,1	53,5	23,4	61,8	27,0	53,4	23,3	61,7	26,9
ELECTRICAL	Continuous current	I <sub>C</sub>	A <sub>RMS</sub>	3,0	6,9	3,0	6,9	6,0	13,7	6,0	13,7	9,0	20,6	9,0	20,6	12,0	27,5	12,0	27,5
	Peak current	I <sub>P</sub>	A <sub>RMS</sub>	9,0	20,6	9,0	20,6	18,0	41,2	18,0	41,2	27,0	61,8	27,0	61,8	36,0	82,4	36,0	82,4
	Ultimate current	I <sub>U</sub>	A <sub>RMS</sub>	15,0	34,3	15,0	34,3	30,0	68,7	30,0	68,7	45,0	103,0	45,0	103,0	60,0	137,4	60,0	137,4
	Resistance at 20 °C phase-phase	R <sub>20</sub>	Ω	8,11	1,55	8,11	1,55	4,06	0,77	4,06	0,77	2,7	0,52	2,7	0,52	2,03	0,39	2,03	0,39
	Resistance at 125 °C phase-phase	R <sub>125</sub>	Ω	11,46	2,19	11,46	2,19	5,74	1,09	5,74	1,09	3,81	0,73	3,81	0,73	2,87	0,55	2,87	0,55
	Induction phase-phase	L <sub>P</sub>	mH	49,5	9,4	49,5	9,4	24,8	4,7	24,8	4,7	16,5	3,1	16,5	3,1	12,4	2,4	12,4	2,4
	Electrical time constant <sup>3</sup>	t <sub>C</sub>	mS	6,1	6,1	6,1	6,1	6,1	6,1	6,1	6,1	6,1	6,0	6,1	6,0	6,1	6,2	6,1	6,2
THERMAL	Max. winding temperature	T <sub>max</sub>	°C 125																
	Max. allowed magnet plate temperature	T <sub>magnet</sub>	°C 90																
	Thermal time constant	τ <sub>th</sub>	s 88																
	Thermal resistance	R <sub>th</sub>	$\frac{K}{W}$	0,68				0,34				0,23				0,17			
	Thermal resistance to heatsink	R <sub>th_HS</sub>	$\frac{K}{W}$	0,180				0,090				0,060				0,045			
	MECHANICAL	Forcer overall length	M <sub>L</sub>	mm 128															
Forcer overall width		M <sub>W</sub>	mm 90																
Forcer overall height		M <sub>H</sub>	mm 23,5																
Forcer mass		m <sub>m</sub>	1,4				2,6				3,8				4,9				
Magnet plate weight		m <sub>S</sub>	$\frac{kg}{m}$	4,4		4,8		4,4		4,8		4,4		4,8		4,4		4,8	
Forcer wires cross-section		S <sub>C</sub>	mm <sup>2</sup> 1,5																
Sensor wires cross-section		S <sub>SC</sub>	mm <sup>2</sup> 0,25																
Forcer cable length		L <sub>M</sub>	mm 1000																
Sensor cable length		L <sub>S</sub>	mm 1000																
Magnet pitch		τ	mm 30																

<sup>1</sup> Magnets at 20 °C

<sup>2</sup> RMS at 0 A and air gap of 0,6 mm

<sup>3</sup> Windings at 20 °C

**i** The specifications were measured without forced cooling. Electrical specifications tolerance is ± 10 %.

Force as a function of velocity diagrams

Bus voltage = 325 V DC

Bus voltage = 565 V DC

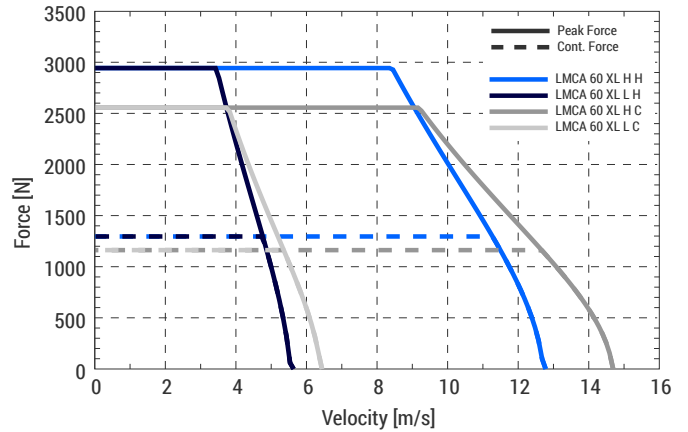
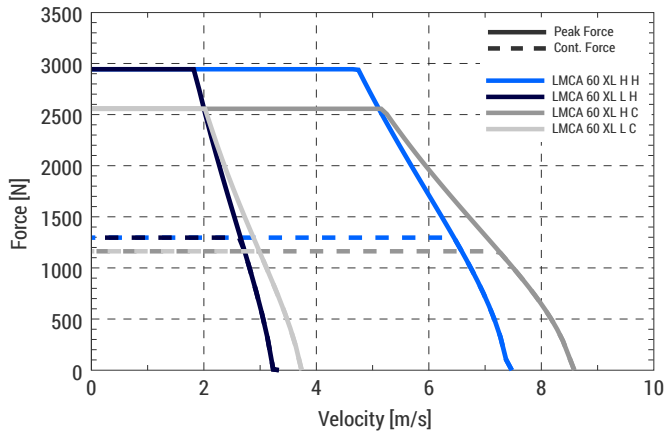
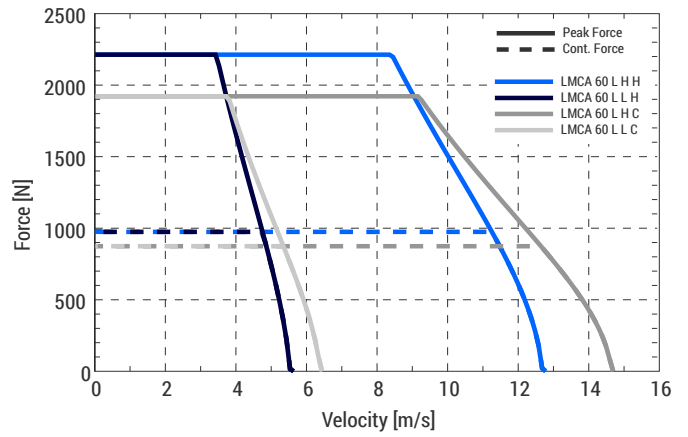
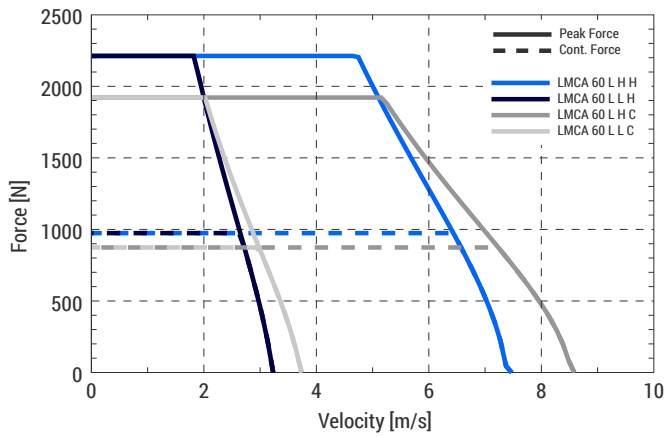
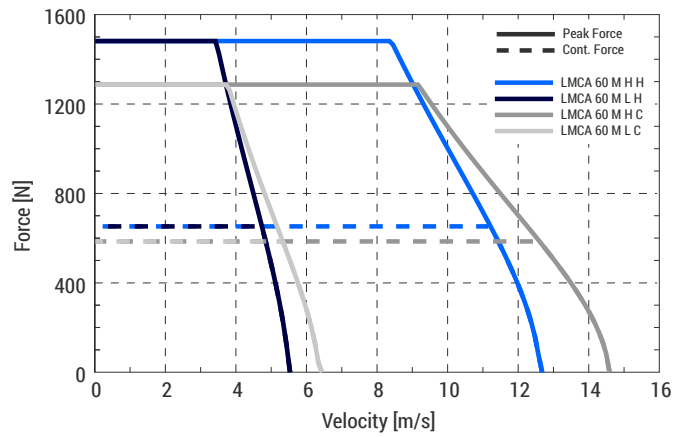
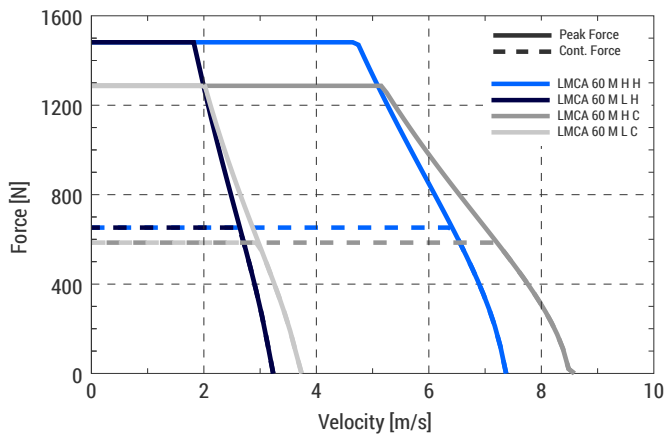
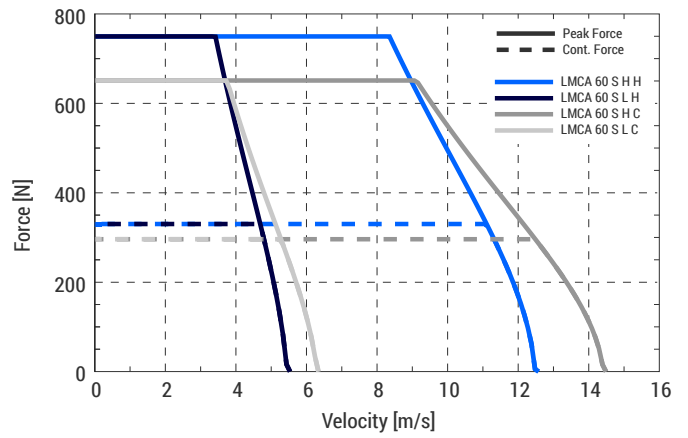
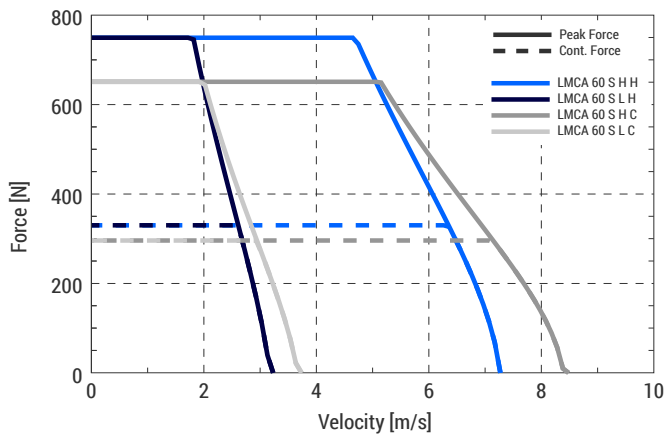

### Forcer dimensions

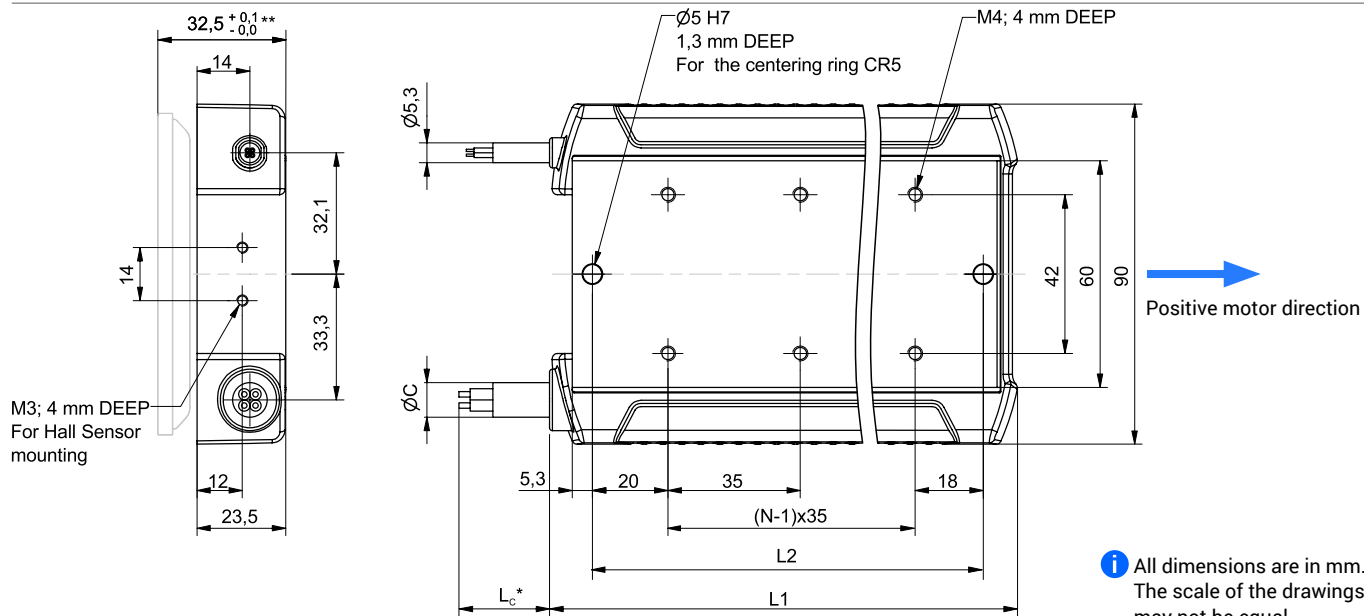

\* Standard cable length  
\*\* The stated mounting height is set for the air gap of 0,6 mm. For more information, please refer to page 9.

**i** All dimensions are in mm. The scale of the drawings may not be equal.

LMCA 60	L1 [mm]	L2 ± 0,02 [mm]	N	∅C	Lc [mm]
LMCA 60 S H/L	128	108	3	9,1	1000
LMCA 60 M H/L	233	213	6	9,1	1000
LMCA 60 L H/L	338	318	9	10,6	1000
LMCA 60 XL H/L	443	423	12	10,6	1000

**i** 'N' is the number of mounting holes in the x-direction.

### Magnet plate dimensions

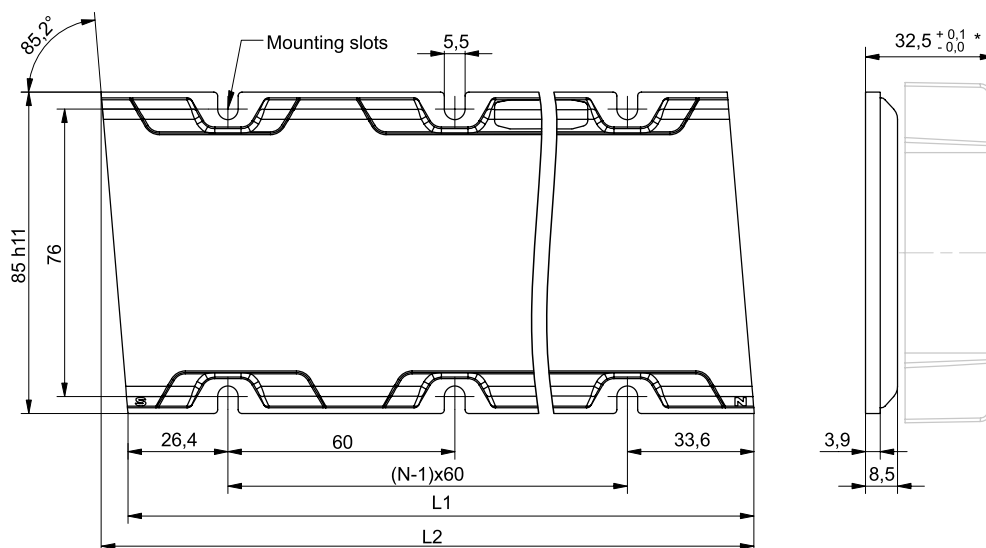

\* The stated mounting height is set for the air gap of 0,6 mm. For more information, please refer to page 9.

MPA 60	L1 [mm]	L2 [mm]	N
MPA 60 120 C/H	120	127,1	2
MPA 60 180 C/H	180	187,1	3
MPA 60 300 C/H	300	307,1	5

**i** 'N' is the number of mounting slots in x-direction.

## LMCA 90

### General technical data

			LMCA 90																
			Version S				Version M				Version L				Version XL				
			Classic		High performance		Classic		High performance		Classic		High performance		Classic		High performance		
PARAMETER	SYM	UNIT	Low speed	High speed	Low speed	High speed	Low speed	High speed	Low speed	High speed	Low speed	High speed	Low speed	High speed	Low speed	High speed	Low speed	High speed	
PERFORMANCE	Max. supply voltage	V <sub>DC</sub>	V (DC) 600																
	Continuous force <sup>1</sup>	F <sub>C</sub>	N 424		472		837		934		1251		1395		1665		1856		
	Peak force (1s) <sup>1</sup>	F <sub>P</sub>	N 932		1073		1842		2120		2751		3168		3661		4215		
	Ultimate force (0,5s) <sup>1</sup>	F <sub>U</sub>	N 1174		1380		2320		2726		3466		4073		4611		5419		
	Attraction force of magnets <sup>2</sup>	F <sub>A</sub>	N 2034		2874		3735		5277		5436		7680		8838		12486		
	Force constant	K <sub>F</sub>	$\frac{N}{A_{RMS}}$	141,3	61,7	157,3	68,7	139,5	60,9	155,7	68,0	139,0	60,7	155,0	67,7	138,8	60,5	154,7	67,5
	Motor constant	K <sub>M</sub>	$\frac{N}{\sqrt{W}}$	34,4	34,4	38,3	38,3	48,0	48,1	53,6	53,7	58,6	58,8	65,4	65,6	67,6	67,3	75,3	75,0
	Back EMF phase-phase constant	K <sub>BEMF</sub>	$\frac{V}{(m/s)}$	81,6	35,6	94,2	41,1	80,6	35,2	93,0	40,6	80,3	35,0	92,7	40,5	80,1	35,0	92,5	40,4
ELECTRICAL	Continuous current	I <sub>C</sub>	A <sub>RMS</sub> 3,0		6,9		6,0		13,7		9,0		20,6		12,0		27,5		
	Peak current	I <sub>P</sub>	A <sub>RMS</sub> 9,0		20,6		18,0		41,2		27,0		61,8		36,0		82,4		
	Ultimate current	I <sub>U</sub>	A <sub>RMS</sub> 15,0		34,3		30,0		68,7		45,0		103,0		60,0		137,4		
	Resistance at 20°C phase-phase	R <sub>20</sub>	Ω	11,24	2,14	11,24	2,14	5,62	1,07	5,62	1,07	3,75	0,71	3,75	0,71	2,81	0,54	2,81	0,54
	Resistance at 125°C phase-phase	R <sub>125</sub>	Ω	15,88	3,02	15,88	3,02	7,94	1,51	7,94	1,51	5,3	1,0	5,3	1,0	3,97	0,76	3,97	0,76
	Induction phase-phase	L <sub>P</sub>	mH	68,8	13,1	68,8	13,1	34,4	6,6	34,4	6,6	22,9	4,7	22,9	4,7	17,2	3,3	17,2	3,3
	Electrical time constant <sup>3</sup>	t <sub>C</sub>	mS	6,1	6,1	6,1	6,1	6,1	6,2	6,1	6,2	6,1	6,6	6,1	6,6	6,1	6,1	6,1	6,1
THERMAL	Max. winding temperature	T <sub>max</sub>	°C 125																
	Max. allowed magnet plate temperature	T <sub>magnet</sub>	°C 90																
	Thermal time constant	τ <sub>th</sub>	s 88																
	Thermal resistance	R <sub>th</sub>	$\frac{K}{W}$	0,49				0,24				0,16				0,12			
	Thermal resistance to heatsink	R <sub>th_HS</sub>	$\frac{K}{W}$	0,125				0,063				0,042				0,031			
MECHANICAL	Forcer overall length	M <sub>L</sub>	mm 128																
	Forcer overall width	M <sub>W</sub>	mm 120																
	Forcer overall height	M <sub>H</sub>	mm 23,5																
	Forcer mass	m <sub>m</sub>	kg 2				3,6				5,3				7				
	Magnet plate weight	m <sub>S</sub>	$\frac{kg}{m}$	7		7,6		7		7,6		7		7,6		7		7,6	
	Forcer wires cross-section	S <sub>C</sub>	mm <sup>2</sup> 1,5																
	Sensor wires cross-section	S <sub>SC</sub>	mm <sup>2</sup> 0,25																
	Forcer cable length	L <sub>M</sub>	mm 1000																
	Sensor cable length	L <sub>S</sub>	mm 1000																
	Magnet pitch	τ	mm 30																

<sup>1</sup> Magnets at 20 °C

<sup>2</sup> RMS at 0 A and air gap of 0,6 mm

<sup>3</sup> Windings at 20 °C

**i** The specifications were measured without forced cooling. Electrical specifications tolerance is ± 10 %.

Force as a function of velocity diagrams

Bus voltage = 325 V DC

Bus voltage = 565 V DC

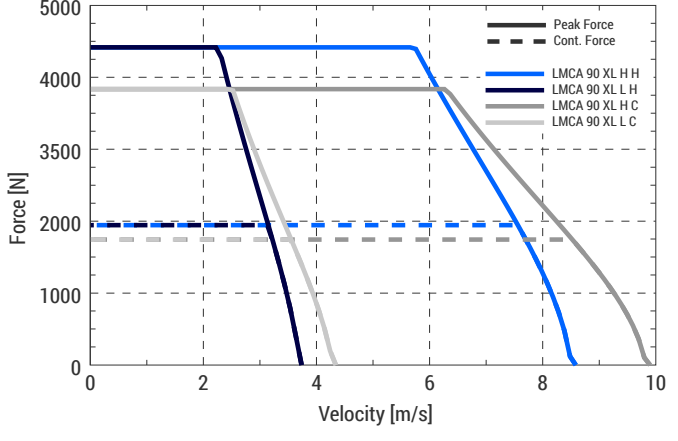
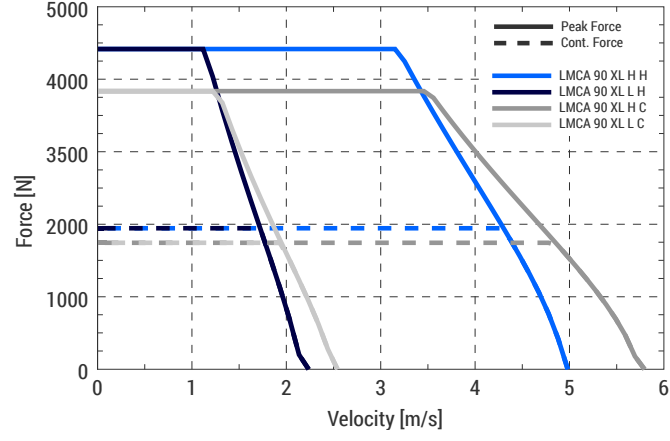
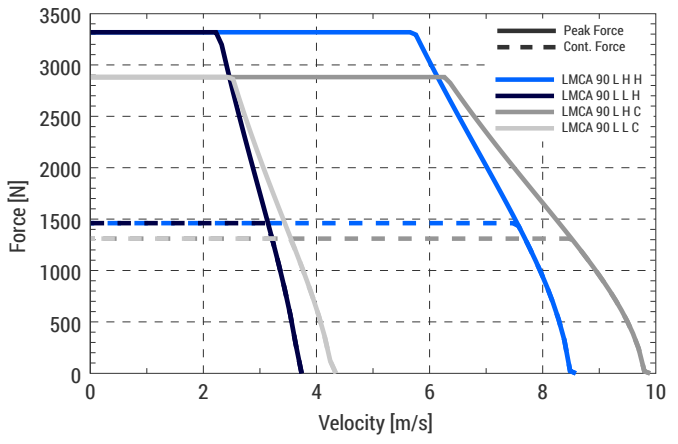
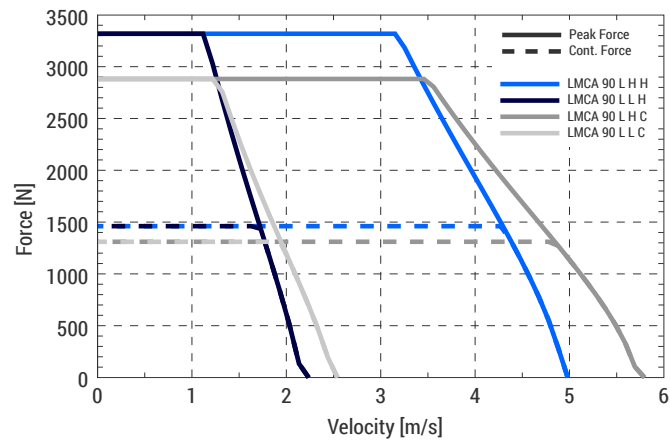
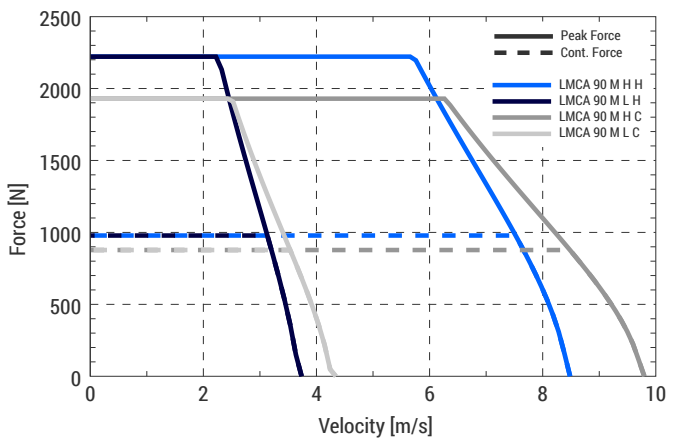
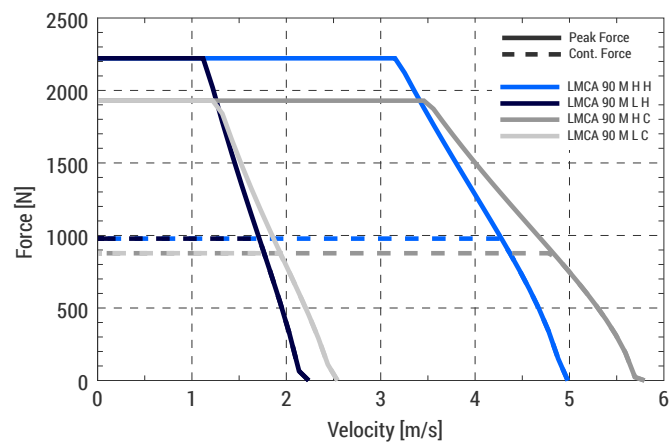
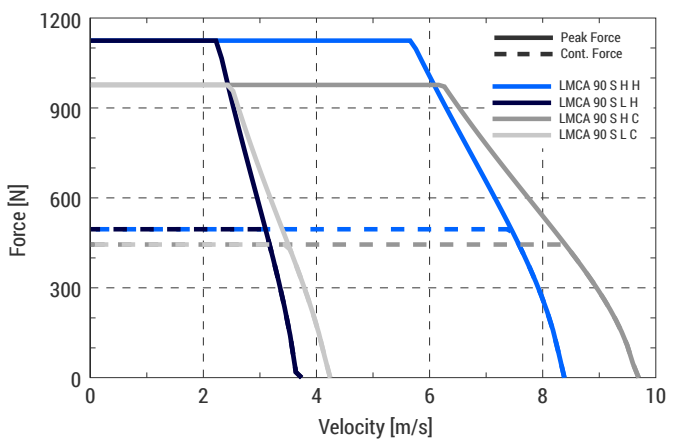
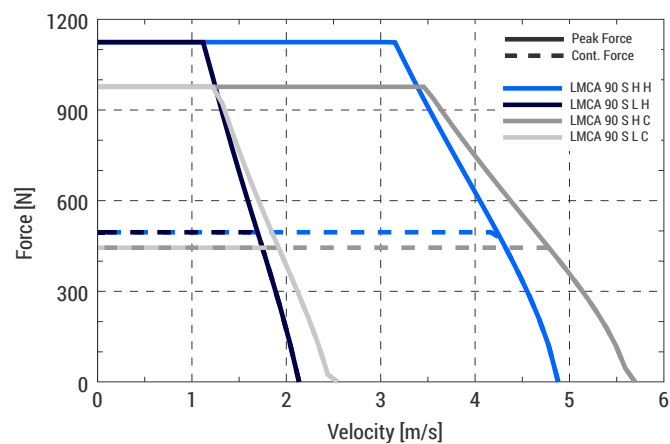

### Forcer dimensions

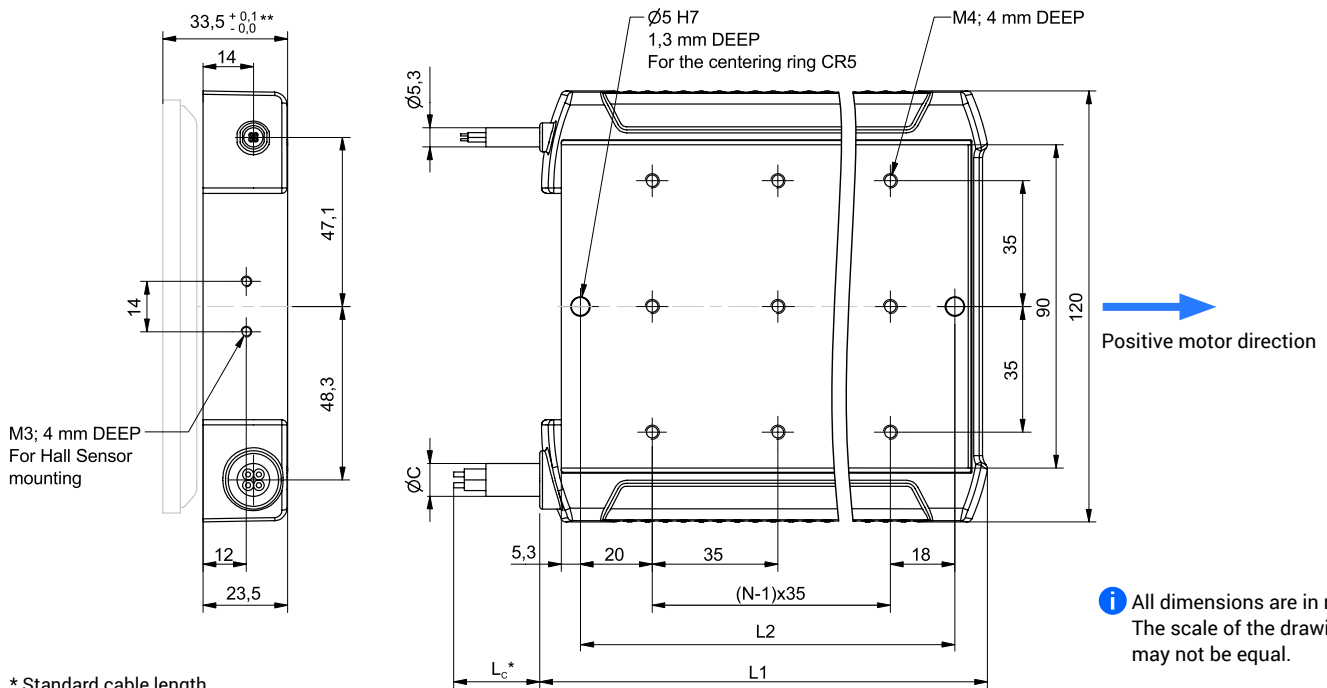

\* Standard cable length  
 \*\* The stated mounting height is set for the air gap of 0,6 mm. For more information, please refer to page 9.

LMCA 90	L1 [mm]	L2 ± 0,02 [mm]	N	ØC	Lc [mm]
LMCA 90 S H/L	128	108	3	9,1	1000
LMCA 90 M H/L	233	213	6	9,1	1000
LMCA 90 L H/L	338	318	9	10,6	1000
LMCA 90 XL H/L	443	423	12	10,6	1000

**i** All dimensions are in mm. The scale of the drawings may not be equal.

**i** 'N' is the number of mounting holes in the x-direction.

### Magnet plate dimensions

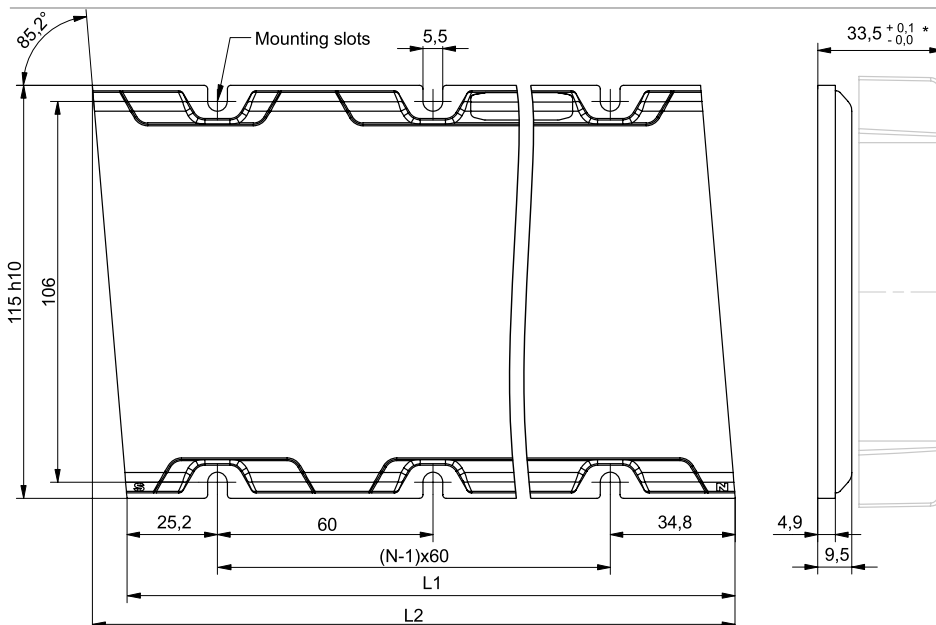

\* The stated mounting height is set for the air gap of 0,6 mm. For more information, please refer to page 9.

MPA 90	L1 [mm]	L2 [mm]	N
MPA 90 120 C/H	120	129,6	2
MPA 90 180 C/H	180	189,6	3
MPA 90 300 C/H	300	309,6	5

**i** 'N' is the number of mounting slots in the x-direction.

## MOUNTING TOLERANCES

### LMCA 30

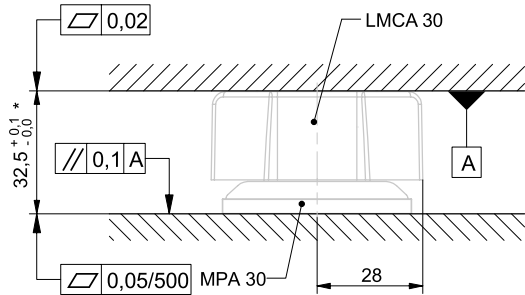

\* The stated mounting height is set for the air gap of 0,6 mm.  
For more information, please refer to page 9.

\*\* We recommend using a thermally conductive paste between the forcer and heatsink to ensure a better heat transfer.

### LMCA 60

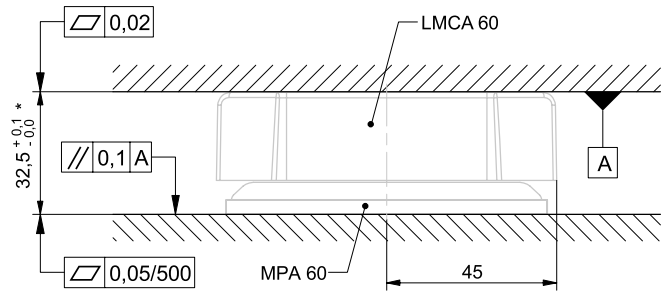

\* The stated mounting height is set for the air gap of 0,6 mm.  
For more information, please refer to page 9.

\*\* We recommend using a thermally conductive paste between the forcer and heatsink to ensure a better heat transfer.

### LMCA 90

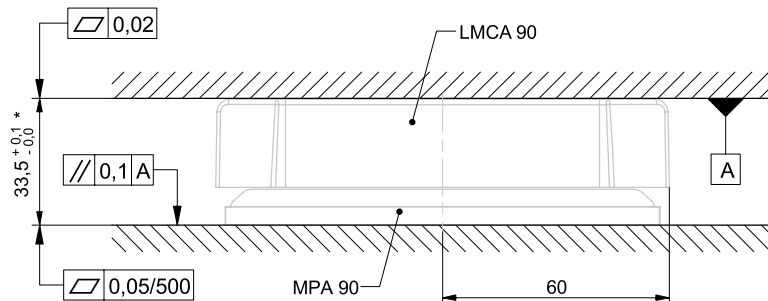

\* The stated mounting height is set for the air gap of 0,6 mm.  
For more information, please refer to page 9.

\*\* We recommend using a thermally conductive paste between the forcer and heatsink to ensure a better heat transfer.

## ELECTRICAL DATA

### Temperature sensors description (KTY83 / PTC)

LMCA linear motors are equipped with two types of temperature sensors which are generally used for overheating protection. The first type is KTY83-122 which is thermally coupled with the U winding. The second one is the PTC, which consists of three PTCs connected in series. The PTC sensors are thermally coupled with U, V, and W windings, whereas the characteristic is harmonized by DIN 44082 standard.

The KTY83 sensor is commonly used for monitoring motor temperature, while the PTC sensor is used for cut-off protection when the motor temperature exceeds the maximum allowed temperature.

For continuous operation, it is recommended that the motor temperature does not exceed 80 % (100 °C) of the maximum allowed motor temperature (125 °C).

### PTC Thermistor

As mentioned in the above description, windings are equipped with three PTC thermistors connected in series. This sensor's characteristic curve has an exponential rise when the temperature of the windings is approaching the maximum temperature of 125 °C. Therefore it can be used as an indicator of signaling critical temperature, which eliminates the need for sensing electronics. With this particular sensor, it is not possible to receive the exact temperature.

In the table below, resistances at specific temperatures are presented.

Resistance of PTCs at ambient temperature (25 °C)	< 300 Ω
Normal operating PTCs resistance (25 °C–120 °C)	< 3000 Ω
Cut-off resistance of PTCs	> 3990 Ω

**i** The resistance is the sum of all three PTCs.

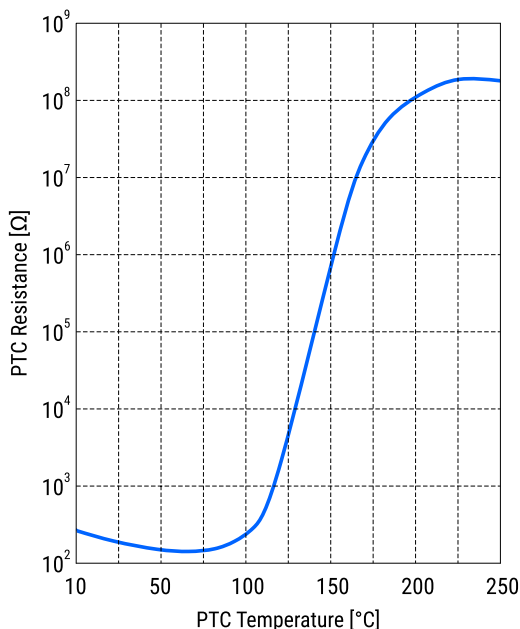

## KTY83-122 Thermistor

As mentioned above, the forcer is equipped with one KTY83-122 thermistor. This sensor's characteristic curve is nearly linear through the whole operating range. The thermal time constant of this sensor is approximately 6 seconds.

With the below equation, you can calculate the temperature of the windings from the current resistance of this KTY83-122 sensor.

The temperature of the windings can be calculated from the current resistance of the KTY83 sensor with the use of the below equation.

$$T = 25 + \frac{\sqrt{\alpha^2 - 4 * \beta + 4 * \beta * \frac{R_T}{R_{25}}} - \alpha}{2 * \beta}$$

Values of specific elements are:

Parameter	Value	Unit
R <sub>T</sub>	*Current sensor reading*	Ω
α	7,88E-03	K <sup>-1</sup>
β	1,94E-05	K <sup>2</sup>
R <sub>25</sub>	1010	Ω

In the table below, resistance values of KTY83 at specific temperatures are presented.

T [°C]	25	30	40	50	60	70	80	90	100	110	120	125	130
R [Ω]	1010	1049	1130	1214	1301	1392	1487	1585	1687	1792	1900	1956	2012

Resistance of KTY at ambient temperature (25 °C)	1010 Ω
Normal operating KTYs resistance (25 °C–120 °C)	< 1900 Ω
Cut-off resistance of KTY	> 1956 Ω

## Pin layout

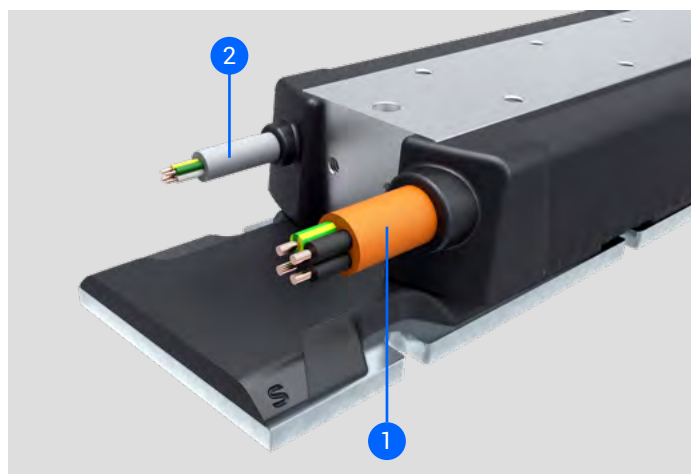

- 1 – Power cable
  - Black: Phase cables (L1, L2, L3)
  - Yellow: Neutral (N) + Ground (Protective Earth, PE)
- 2 – Temperature sensor cable
  - Yellow & Green: PTC Thermistors
  - White & Brown: KTY Thermistor

# UNIMOTION

## CALCULATE AND CONFIGURE YOUR OWN SOLUTION

The LINEAR MOTOR CALCULATION TOOL is an online application that enables quick and easy selection of a suitable product, with the possibility of achieving the optimal ratio between the given capacity and the price and the creation of the 3D models.

For more information please contact us or visit our website.

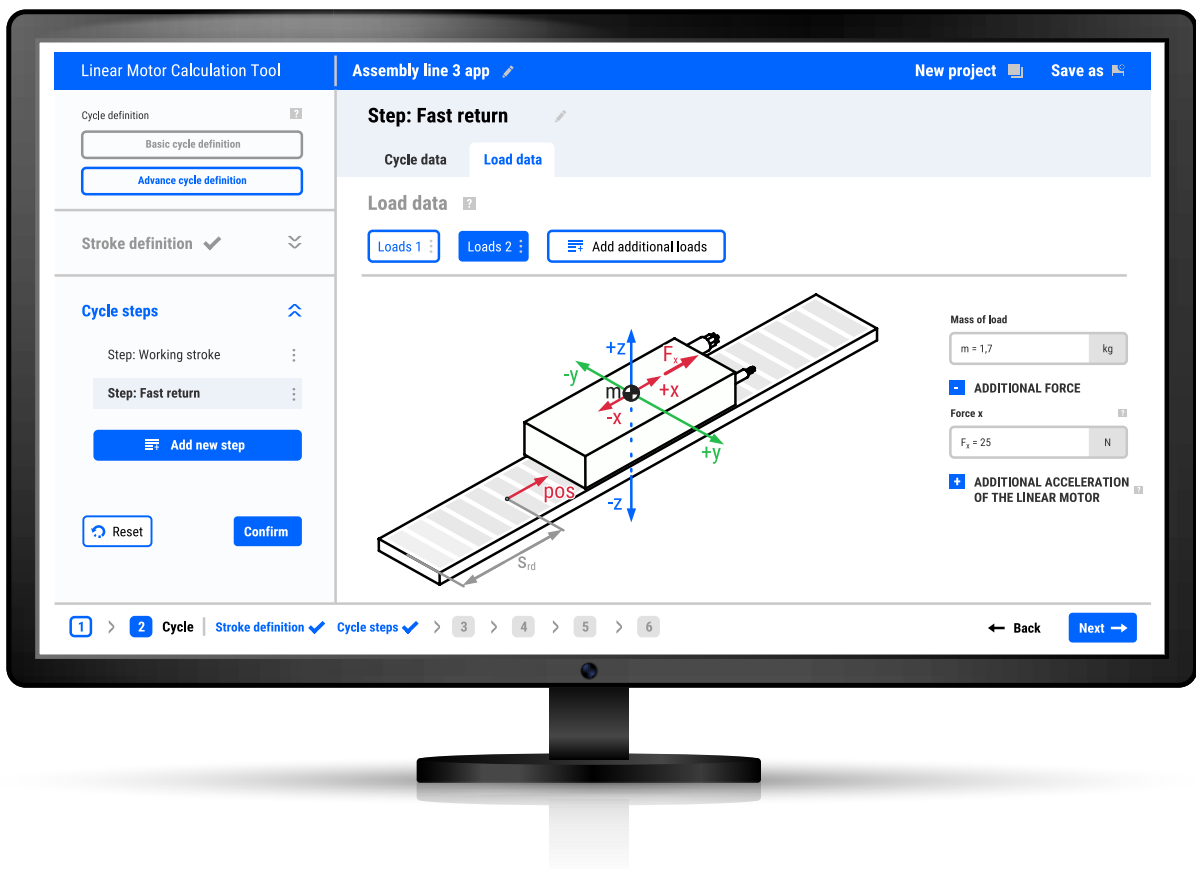

**LMCA Hall sensor**

## Description

UNIMOTION offers a Hall sensor which was specifically developed for the LMCA linear motors. The sensor utilizes existing magnet feedback which allows an unmatched accuracy to price ratio. Its main advantage is integration of the analog and digital sensors into one housing.



Our Hall sensor can be used for a cost-effective solution when the position accuracy demands are not very high. Repeatable accuracy is in the range of 30  $\mu\text{m}$  whilst absolute accuracy is in the range of 100  $\mu\text{m}$ . With the integration of both sensors, analog is used for exact position control, where digital is used for commutation. A combination of both offers the customer a free “wake & shake” operation feature.

The sensor is equipped with 10 highly flexible shielded wires, which are suitable for use in the energy chains. The digital sensor generates the U, V, and W signal outputs with a 120° phase shift while the analog sensor generates sine and cosine signals with an amplitude of 1  $V_{pp}$ . For the best resistance against the EMC, the signals are differential, i.e.: sine: A+, A- and cosine: B+, B-.

Our Hall sensor enables easy and precise mounting which results in an ideal alignment of the sensors and motor windings.

## Specifications table

### Absolute maximum ratings:

Parameter	Min	Max	Unit
Power supply voltage $V_{CC}$	-0,3	6	$V_{DC}$
Output pin current U, V, W, A+, A-, B+, B-	0	-100	mA
Operating junction temperature, $T_J$	-15	85	°C
Storage temperature, $T_{stg}$	-25	90	°C

### Recommended operating conditions:

Parameter	Min	Max	Unit
Power supply voltage $V_{CC}$	4,9	5,5	$V_{DC}$
Power supply current	30	50	mA
Output current	-	5	mA
Output voltage A+ to A- and B+ to B-	0,8	1,2	$V_{pp}$
Operating junction temperature, $T_J$	-15	85	°C
Storage temperature, $T_{stg}$	-25	90	°C

### Technical specifications:

Parameter	Value	Unit
Sensor accuracy	+/- 250*	$\mu\text{m}$
Repeatability	+/- 30	$\mu\text{m}$
Hysteresis	+/- 10	$\mu\text{m}$
Signal period	30	mm
Cable	LAPP UNITRONIC FD CP plus 10 x 0,14	/
Cable bending radius (fixed installation)	26,8	mm
Cable bending radius (flexible installation)	50,25	mm

\* In case of drive compensation, the accuracy can be higher.

## Dimensions

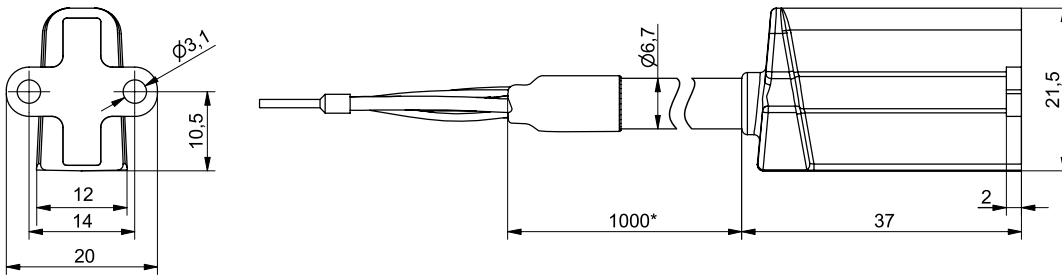

\* Standard cable length.  
For different lengths, please refer to the "Hall sensor – How to order" section.

**i** All dimensions are in mm.  
The scale of the drawings may not be equal.

## Pin layout

Parameter	Symbol	Wire colour
Analog hall output A+	A+	Yellow
Analog hall output A-	A-	Green
Analog hall output B+	B+	Violet
Analog hall output B-	B-	White
Digital hall output U	U	Gray
Digital hall output V	V	Black
Digital hall output W	W	Pink
Power supply +5 V <sub>DC</sub>	+5 V <sub>DC</sub>	Red
Power supply GND	GND	Blue
Cable screen	EARTH	Screen

## How to order

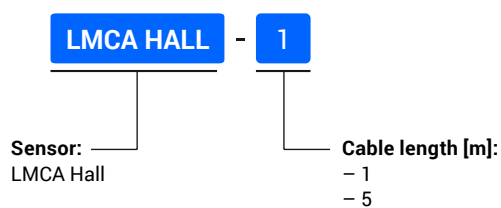

## **Motor selection example**

**Motor selection guide:**

The proper motor selection is done in three steps:

- I. Definition of the motion profile
- II. Calculation of continuous and peak forces
- III. Motor selection

**I. Definition of the motion profile**

There is a wide range of different motion profiles which can be expressed by basic kinematic equations. The most commonly used motion profiles are trapezoidal and triangular.

**Trapezoidal profile:**

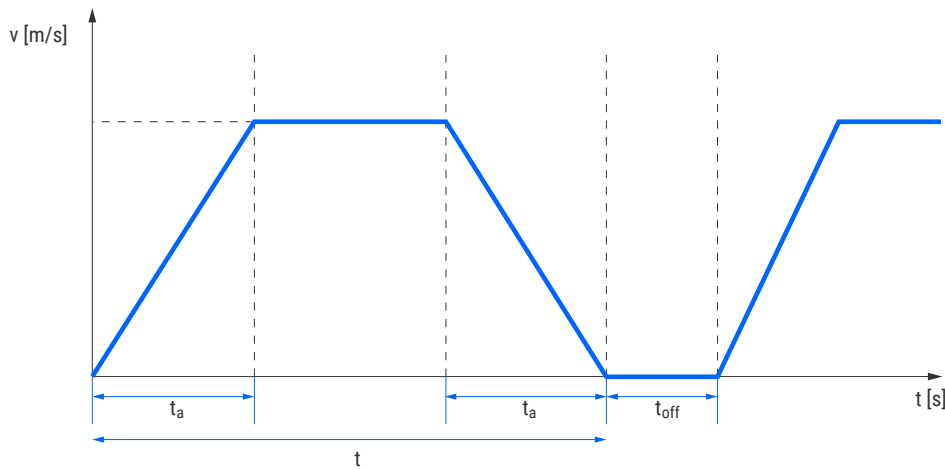

Moving input data:

L	Moving distance (stroke)	[m]
t	Moving time	[s]
t <sub>a</sub>	Acceleration time	[s]
t <sub>off</sub>	Pause	[s]

Average velocity:

$$v = \frac{L}{t}$$

Maximum velocity:

$$v_{max} = \frac{L}{t - t_a}$$

Acceleration/deceleration:

$$a = \frac{v_{max}}{t_a}$$

Where is:

v	Average velocity	[m/s]
v <sub>max</sub>	Maximum velocity	[m/s]
L	Moving distance	[m]
t	Moving time	[s]
t <sub>a</sub>	Acceleration time	[s]
a	Acceleration/deceleration	[m/s <sup>2</sup> ]

Triangular profile:

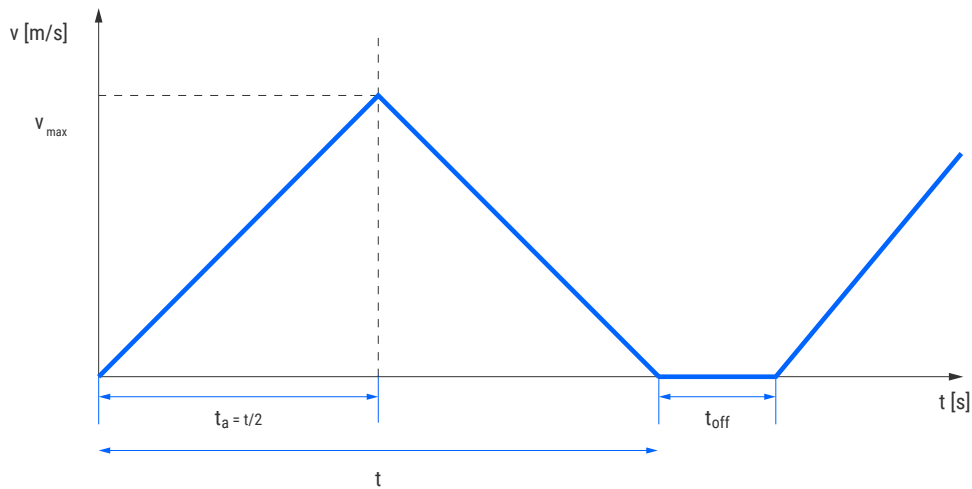

Moving input data:

L	Moving distance (stroke)	[m]
t	Moving time	[s]
t <sub>a</sub>	Acceleration time	[s]
t <sub>off</sub>	Pause	[s]

Average velocity:

$$v = \frac{L}{t}$$

Maximum velocity:

$$v_{max} = \frac{a}{t_a}$$

Acceleration/deceleration:

$$a = \frac{4 * L}{t^2}$$

Where is:

v	Average velocity	[m/s]
v <sub>max</sub>	Maximum velocity	[m/s]
L	Moving distance	[m]
t	Moving time	[s]
t <sub>a</sub>	Acceleration time	[s]
a	Acceleration/deceleration	[m/s <sup>2</sup> ]

## II. Calculation of continuous and peak forces

When velocity and acceleration are defined, we can proceed to the calculation of continuous and peak forces which the motor has to overcome.

Input parameters:

$m_{load}$	Mass of load	[kg]
$k_f$	Friction coefficient	
$F_A$	Attraction force (you can find it in the motor specification)	[N]
$\alpha$	Inclination angle	[°]

Peak force can be calculated by the following equation:

$$F_p = F_{mass} + F_{fri} + F_{incl}$$

$$F_{mass} = a * m_{load}$$

$$F_{fri} = k_f (g * m_{load} * \cos\alpha + F_A)$$

$$F_{incl} = m_{load} * g * \sin\alpha$$

Where is:

$F_p$	Peak force	[N]
$a$	Acceleration	[m/s <sup>2</sup> ]
$m_{load}$	Mass of load	[kg]
$k_f$	Friction coefficient	
$g$	Gravitational constant (9,81)	[m/s <sup>2</sup> ]
$F_A$	Attraction force	[N]
$\alpha$	Inclination angle	[°]
$F_{incl}$	Inclination force (if the motor is placed horizontally ( $\alpha = 0^\circ$ ) the $F_{incl}$ is 0)	[N]

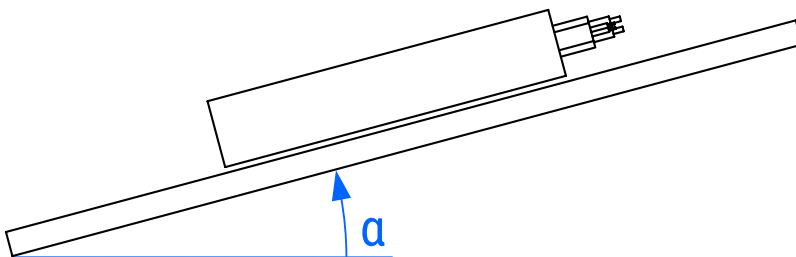

Continuous force can be calculated by following equation:

$$F_c = \sqrt{\frac{F_p^2 * t_a + (F_{fri} + F_{incl})^2 * (t - 2t_a) + (F_{mass} + F_{incl} - F_{fri})^2 * t_a}{t + t_{off}}}$$

### III. Motor selection

#### Defining the motors RMS and MAX current:

$$I_{MAX} = \frac{F_P}{K_F} < I_P \text{ from the motor specification.}$$

$$I_{RMS} = \frac{F_C}{K_F} < I_C \text{ from the motor specification.}$$

**i** We recommend a safety factor where  $I_P$  and  $I_C$  are 30 % higher than  $I_{MAX}$  and  $I_{RMS}$ .

Where is:

$F_P$	Peak force	[N]
$F_C$	Continuous force	[N]
$K_F$	Force constant (you can find it in the motor specifications)	[N/A <sub>RMS</sub> ]

#### Motor voltage calculation:

For the proper motor selection, the correct voltage must be calculated with the below equation:

$$V_{mot} = \sqrt{\left(\frac{\sqrt{2} v_{max} * K_{BEMF}}{\sqrt{3}} + \frac{F_P}{K_F} * R_{20} * \frac{\sqrt{2}}{2}\right)^2 + \left(\sqrt{2} * 2\pi * \frac{F_P * L_P}{K_F * 2 * \tau}\right)^2}$$

Where is:

$v_{max}$	Maximum velocity	[m/s]
$K_{BEMF}$	Motor induction voltage phase-phase RMS (listed in the motor specifications)	[V/m/s]
$K_F$	Force constant (listed in the motor specifications)	[N/A <sub>RMS</sub> ]
$F_P$	Peak force	[N]
$R_{20}$	Phase-phase resistance (listed in the motor specifications)	[Ω]
$L_P$	Phase-phase inductance	[H]
$\tau$	Magnet pitch (listed in the motor specifications)	[m]

Available drive voltage can be calculated with the following equations:

$$V_{drive\_SVM} = \frac{\sqrt{2} V_{supply}[VAC]}{\sqrt{3}} ; \text{ In the case of AC power supply}$$

$$V_{drive\_SVM} = \frac{V_{supply}[VDC]}{\sqrt{3}} ; \text{ In the case of DC power supply}$$

Where is:

$V_{supply}$	Drive supply voltage (for example 230 V AC or 400 V DC)	[V <sub>RMS</sub> ]
$V_{drive\_SVM}$	The available voltage that can be applied to the linear motor	[V]

#### Motor selection condition:

Drive voltage must be higher than the maximum voltage of the motor.

$$V_{mot} < V_{drive\_SVM}$$

**i** A safety factor where  $V_{drive\_svm}$  is 30 % higher than  $V_{mot}$  is recommended.

## Selection example

### I. Definition of the motion profile

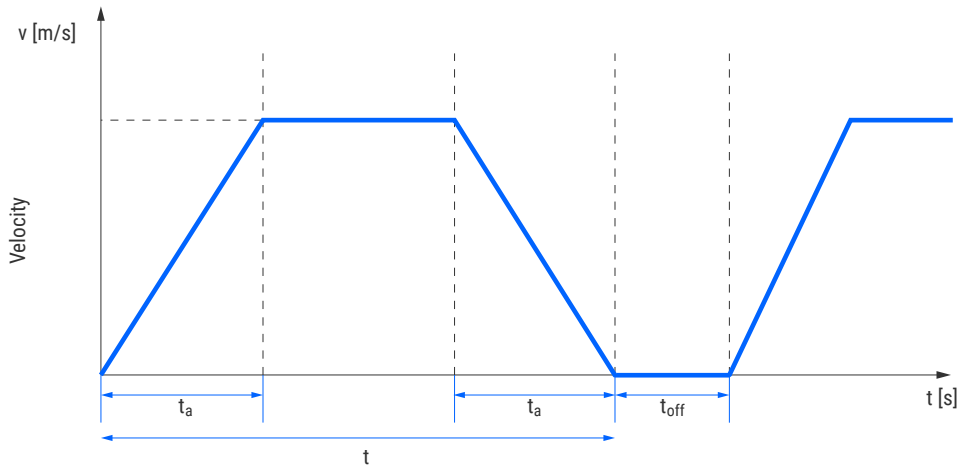

- Moving distance  $L = 2$  m
- Moving time  $t = 2$  s
- Acceleration time  $t_a = 0,5$  s
- Pause  $t_{off} = 1$  s
- Mass of load  $m_{load} = 50$  kg
- Friction coefficient  $k_f = 0,01$
- $\alpha = 0^\circ$

Average velocity:

$$v = \frac{L}{t} = \frac{2}{2} = \mathbf{1 \text{ m/s}}$$

Maximum velocity:

$$v_{max} = \frac{L}{t - t_a} = \frac{2}{2 - 0,5} = \mathbf{1,33 \text{ m/s}}$$

Acceleration/deceleration:

$$a = \frac{v_{max}}{t_a} = \frac{1,33}{0,5} = \mathbf{2,66 \text{ m/s}^2}$$

### II. Continuous and peak force calculation

**Peak force:**

$$F_{mass} = a * m_{load} = 2,66 * 50 = \mathbf{133,3 \text{ N}}$$

$$F_f = k_{fri}(g * m_{load} * \cos\alpha + F_A) = 0,01(9,72 * 50 * \cos 0 + 958) = \mathbf{14,44 \text{ N}}$$

$$F_{incl} = m_{load} * g * \sin\alpha = \mathbf{0 \text{ N}}$$

$$F_p = F_{mass} + F_f + F_{incl} = 133,3 + 14,47 = \mathbf{147,7 \text{ N}}$$

Motor related parameters can be found in the motor specification:

- Attractive force  $F_A = 958$  N

**Continuous force:**

$$F_C = \sqrt{\frac{F_P^2 * t_a + (F_{fri} + F_{incl})^2 * (t - 2t_a) + (F_{mass} + F_{incl} - F_{fri})^2 * t_a}{t + t_{off}}}$$

$$= \sqrt{\frac{147,7^2 * 0,5 + 14,44^2 * (2 - 2 * 0,5) + (133,3 + 0 - 14,44)^2 * 0,5}{2 + 1}} = 77,85 \text{ N}$$

Motor related parameters, can be found in the motor specification:

- Attractive force  $F_A = 958 \text{ N}$

**III. Motor selection**

**Maximum motor current:**

$$I_{MAX} = \frac{F_P}{K_F} = \frac{147,7}{52,7} = 2,8 \text{ A}_{RMS} < 9,0 \text{ A}_{RMS}$$

**Continuous motor current:**

$$I_{RMS} = \frac{F_C}{K_F} = \frac{77,85}{52,7} = 1,48 \text{ A}_{RMS} < 3,0 \text{ A}_{RMS}$$

Motor related parameters can be found in the motor specifications:

- Attractive force  $F_A = 958 \text{ N}$
- $K_F = 52,7 \text{ N/A}_{RMS}$
- $I_C = 3,0 \text{ A}_{RMS}$
- $I_P = 9,0 \text{ A}_{RMS}$

**Motor voltage calculation:**

For a proper motor selection, voltage is also important, which must be applied by the servo drive. Maximum voltage is calculated by:

$$V_{mot} = \sqrt{\left(\sqrt{2} \frac{v_{max} * K_{BEMF}}{\sqrt{3}} + \frac{F_P}{K_F} * R_{20} * \frac{\sqrt{2}}{2}\right)^2 + \left(\sqrt{2} * 2\pi * \frac{F_P * L_P}{K_F * 2 * \tau}\right)^2}$$

$$= \sqrt{\left(\sqrt{2} \frac{1,33 * 31,4}{\sqrt{3}} + \frac{147,7}{52,7} * 4,99 * \frac{\sqrt{2}}{2}\right)^2 + \left(\sqrt{2} * 2\pi * \frac{147,7 * 0,0282}{52,7 * 2 * 0,03}\right)^2} = 45,5 \text{ V}$$

Motor related parameters can be found in the motor specification:

- Attractive force  $F_A = 958 \text{ N}$
- $K_F = 52,7 \text{ N/A}_{RMS}$
- $K_{BEMF} = 31,4 \text{ V/m/s}$
- $R_{20} = 4,99 \Omega$
- $L_P = 28,2 \text{ mH}$
- $\tau = 30 \text{ mm}$

**Available drive voltage:**

$$V_{supply} = 230 \text{ V}_{AC}$$

$$V_{drive\_SVM} = \frac{\sqrt{2} * V_{supply}}{\sqrt{3}} = \frac{\sqrt{2} * 230}{\sqrt{3}} = 187,8 \text{ V} > 45,5 \text{ V}$$

# UNIMOTION



**We cover all major markets.** If you wish to contact us, send us an enquiry and we will be happy to assist you.

## GERMANY

Unimotion GmbH

[www.unimotion.de](http://www.unimotion.de)  
[vertrieb@unimotion.de](mailto:vertrieb@unimotion.de)

## NORTH AMERICA

Unimotion North America, Inc.

[www.unimotionusa.com](http://www.unimotionusa.com)  
[info@unimotionusa.com](mailto:info@unimotionusa.com)