



Compliant with ISO, DIN, and JIS standards



High-Speed, Compact Caged Ball Screw

# SDA-V/SDAN-V

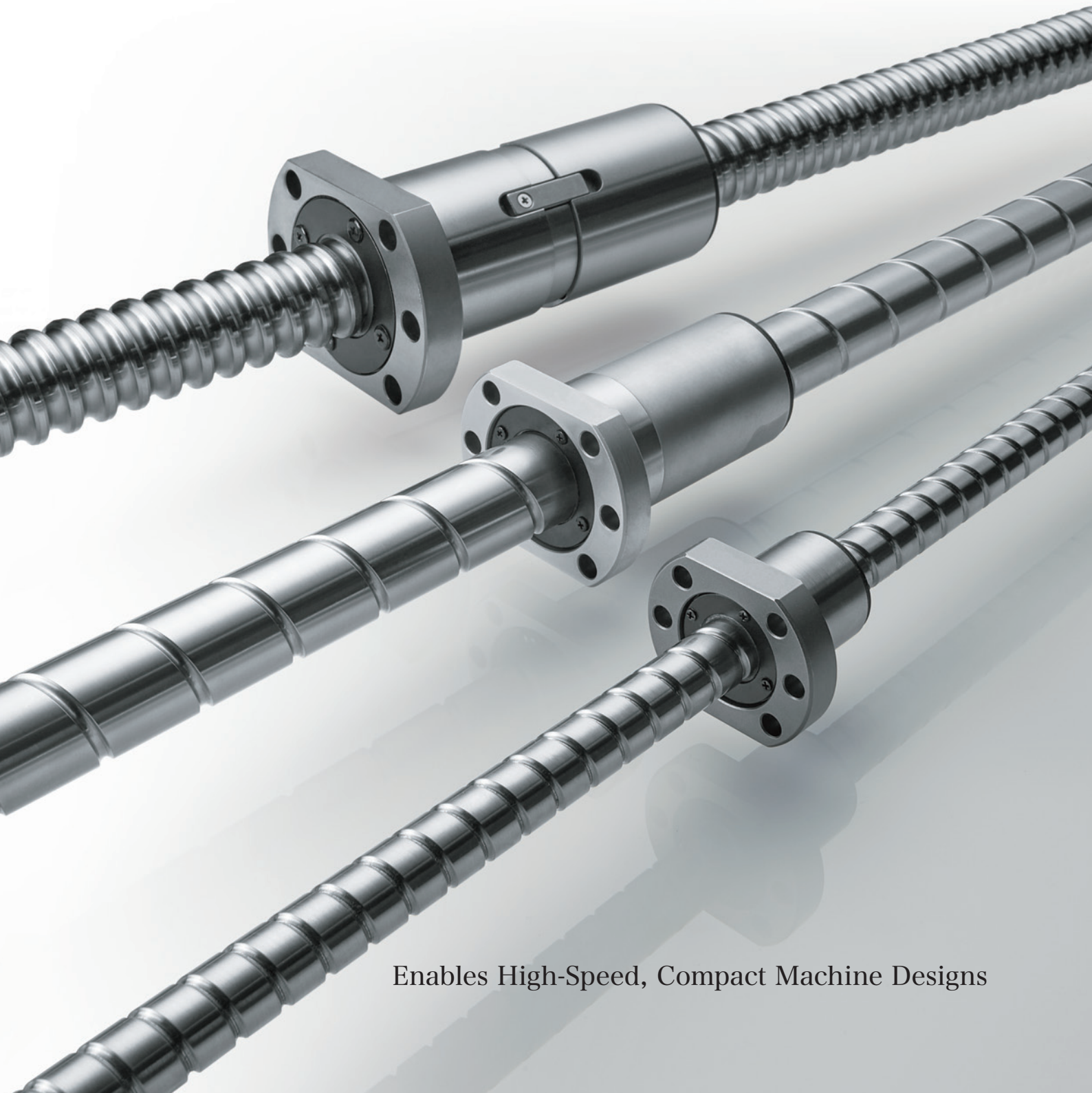

Enables High-Speed, Compact Machine Designs

# SDA-V

## SDA-V/SDAN-V

### ■ High Speed

Picks up balls in the tangential direction and achieves a maximum rotational speed of  $5,000 \text{ min}^{-1}$  (DN value: 160,000).

Torque remains stable even during long periods of high-speed operation.

Conventional precision ball screw  
(Caged Ball type)

Maximum DN value  
130,000

SDA-V/SDAN-V  
(Caged Ball type)

Maximum DN value  
160,000

### ■ Conforms to DIN Standards

The outer diameter is up to 30% more compact than previous THK products.

Enables compact machine designs.

Nut dimensions conform to ISO standards (ISO 3408).

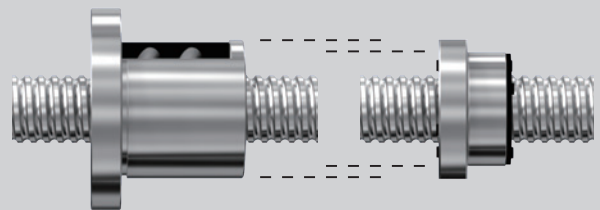

Conventional precision ball screw

SDA-V

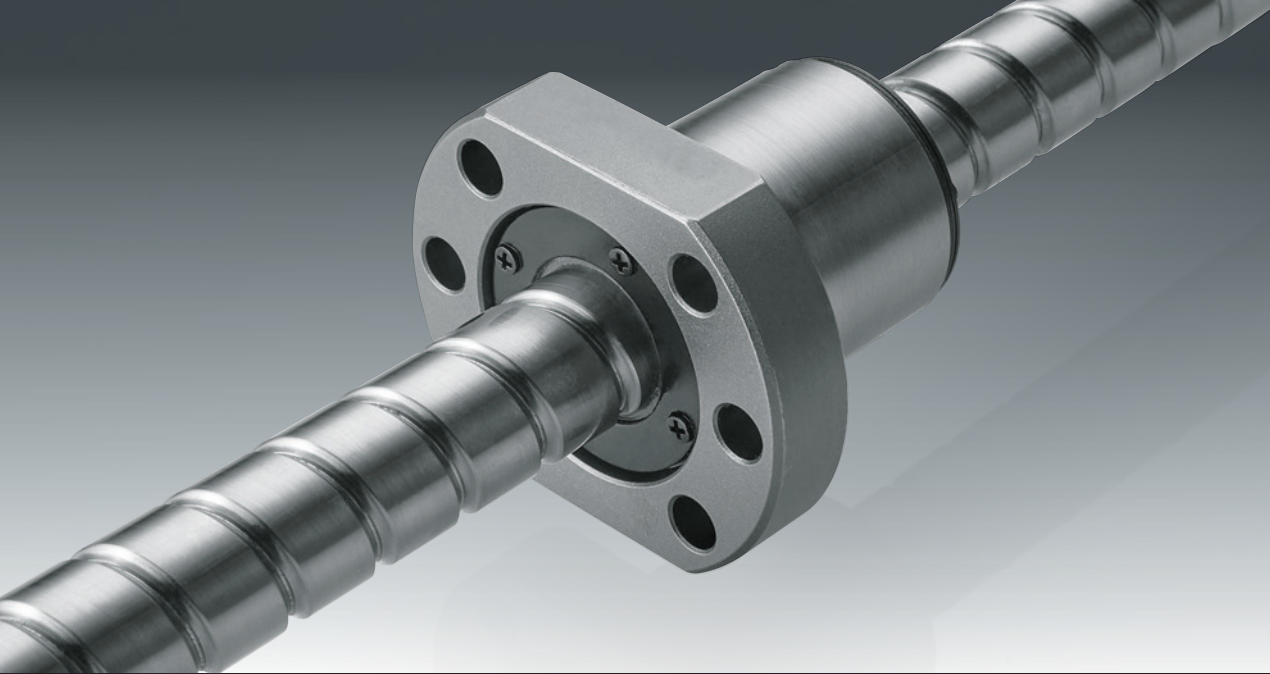

## Enables High-Speed, Compact Machine Designs

### Picks Up Balls in the Tangential Direction

Newly developed circulation components enable an ideal ball circulation structure.



Ball Ball cage

### Model SDA-V/SDAN-V Lineup

A diverse product lineup to meet your varied needs. Full-Ball types are also available.

● : Model SDA-V  
■ : Model SDAN-V

Shaft diameter \ Lead	4	5	6	8	10	12	15	16	20	25	30	32	36	40	50	60
10	●	●			●											
12		●			●				●		●					
14		●			●											
15		●			●				●		●					
16		●			●			●								
20	●	●	●		●			●			●			●		●
25		●			●			●		●	●				●	
28			●		●			●		●	●					
31					●	●		●	●							
32		●	●	●	●	●		●	●			●				
36			●		●	●		●	●	●			●			
38					●	●		●	●	●	●					
40				●	●	●		●	●	●	●			●		
45					●	●		●	●	●	●			●		
50					●	●		●	●	●	●			●	●	
55					●	●		●	●	●	●			●	●	
63					●	●		●	●	●	●			●	●	

# SDAN-V

## SDA-V

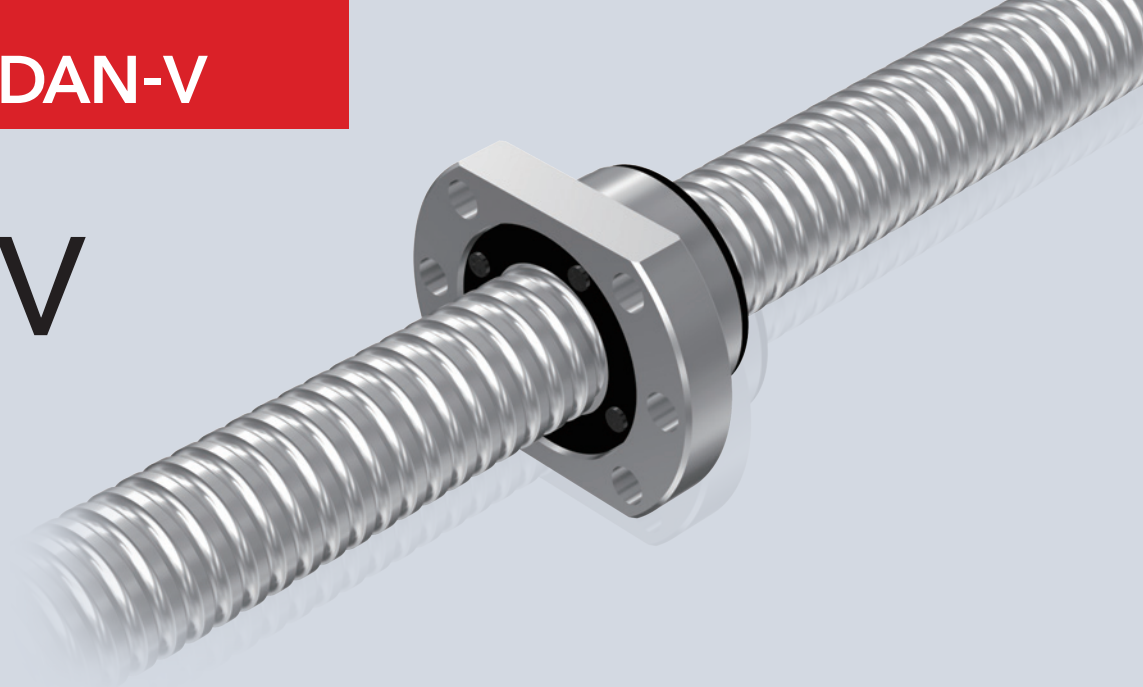

Can be used for a **wide range** of applications, from small electronic component machinery to large general industrial equipment.

- 108 products are available with a combination of shaft diameters from  $\phi 10$  to  $\phi 50$  and leads from 4 mm to 60 mm.
- Clearance can be selected, including an axial clearance of 0 or less.

### Model SDA-V Lineup

Shaft diameter \ Lead	4	5	6	8	10	12	15	16	20	25	30	32	36	40	50	60
10	•	•			•											
12		•			•				•		•					
14		•														
15		•			•				•		•					
16		•			•			•								
20	•	•	•		•				•		•			•		•
25		•			•				•	•	•				•	
28			•													
31					•	•		•	•			•				
32		•	•	•	•	•		•	•			•				
36					•	•		•	•				•			
38					•	•	•	•	•	•	•					
40				•	•	•	•	•	•	•	•			•		
45					•	•	•	•	•	•	•			•		
50					•	•		•	•	•	•			•	•	

### Full-Ball Type (Model SDA-VZ)

Full-Ball types are also available. To request Full-Ball types, please contact THK.

### Model Number Coding Sample

Select an option

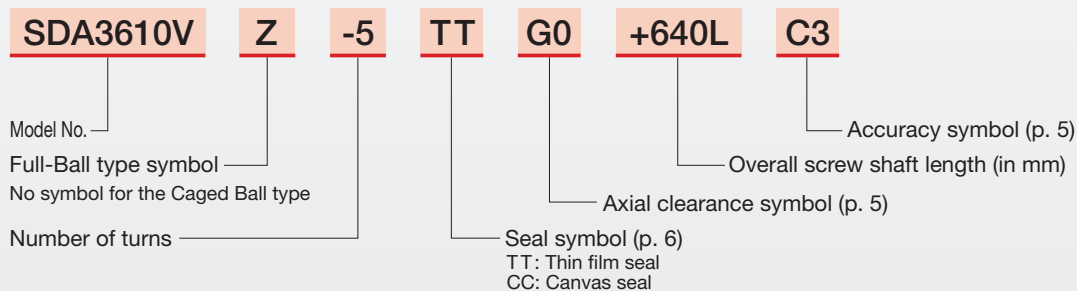

# SDAN-V

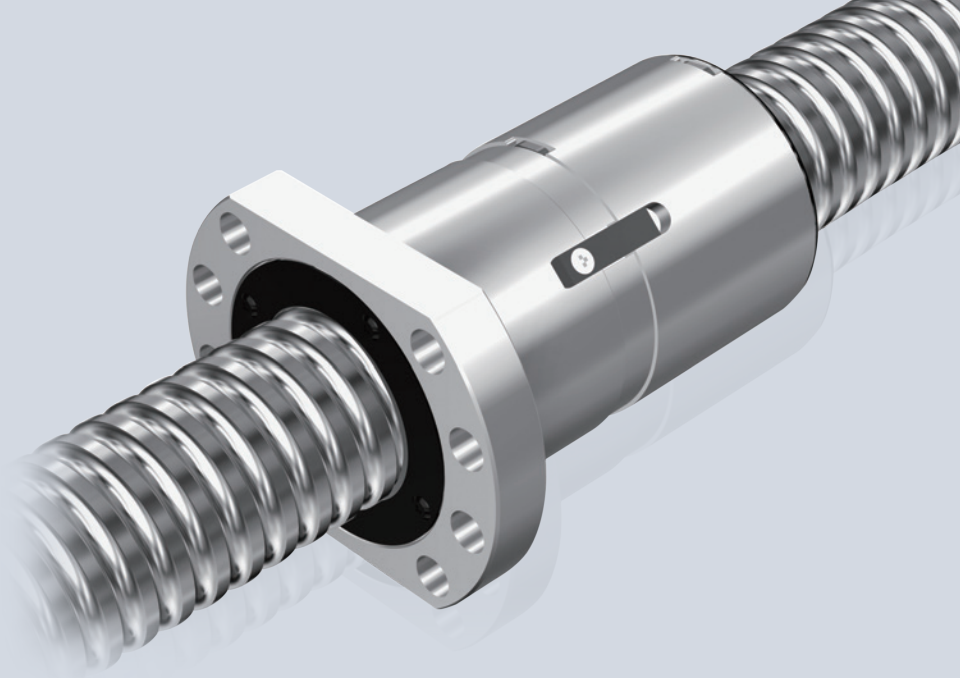

Suitable when it is necessary to minimize displacement from the force of cutting in NC machine tools and precision equipment.

- Designed with higher axial rigidity than the Model SDA-V.
- A double nut is used to achieve an axial clearance of 0 or less.

## Model SDAN-V Lineup

Shaft diameter \ Lead	5	6	8	10	12	16	20	25	30	40
31				■	■	■	■			
32	■	■	■	■	■	■	■			
36		■		■	■	■	■			
38				■	■	■	■			
40			■	■	■	■	■			
45				■	■	■	■			
50				■	■	■	■	■	■	■
55				■	■	■	■			
63				■	■	■	■	■	■	■

## Full-Ball Type (Model SDAN-VX)

Full-Ball types are also available. To request Full-Ball types, please contact THK.

## Model Number Coding Sample

■ Select an option    ■ Fixed symbol

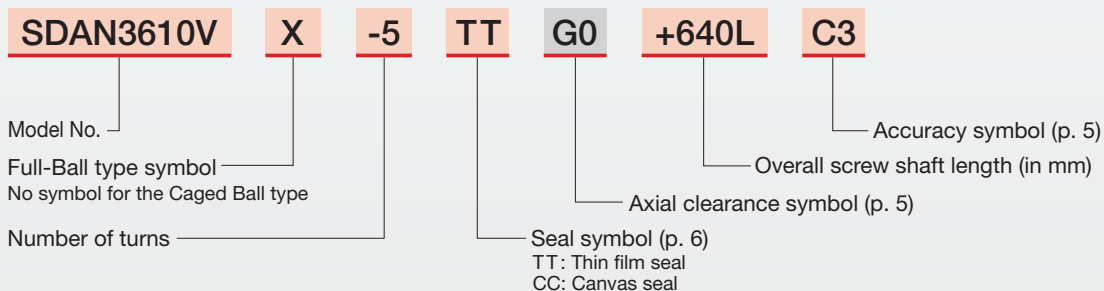

## Lead Angle Accuracy and Axial Clearance

### Lead Angle Accuracy

Complies with conventional JIS (Japanese Industrial Standards) as well as ISO (international standards) and DIN (German industry standards).

### Axial Clearance

The table on the right shows the axial clearance of the precision ball screw.

The Model SDAN-V is only available with G0 clearance.

### Accuracy Standard Compatibility

Accuracy standards	Lead angle accuracy (permissible value)						
	JIS	C0	C1	C2*	C3	C5	C7*
ISO (DIN)	—	—	Cp1	—	Cp3	Cp5	—

\*THK standard lead angle accuracy

Clearance symbol	Unit: mm				
	G0	GT	G1	G2	G3
Axial clearance	0 or less	0 to 0.005	0 to 0.01	0 to 0.02	0 to 0.05

## Static Safety Factor

For ball screws, a static safety factor based on the calculated maximum axial load and static load rating must be considered. Vibrations, impacts, or inertia due to starting and stopping may result in an unexpectedly large load. Therefore, please confirm that a sufficient static safety factor has been ensured when selecting a model. Estimates for the static safety factor are shown in the table below.

### Static Safety Factor $f_s$

$$f_s = \frac{C_{0a}}{F_{a\max}}$$

$f_s$  : Static safety factor

$C_{0a}$  : Basic static load rating<sup>1</sup> (kN)

$F_{a\max}$  : Permissible axial load (kN)

### Estimates of the Static Safety Factor ( $f_s$ )

Load conditions <sup>2</sup>	Lower limit of $f_s$
Without vibrations or impacts	2
With vibrations or impacts	5

<sup>1</sup>The basic static load rating ( $C_{0a}$ ) is a static load with a constant direction and magnitude whereby the sum of the permanent deformation of a ball and that of a rolling groove on a contact area under the maximum stress is 0.0001 times that of the ball diameter. With the ball screw, it is defined as the axial load. (Specific values of each ball screw model are indicated in the dimensional tables for the corresponding model.)

<sup>2</sup>Vibrations and impacts are typically caused by factors such as acceleration and deceleration, sudden starting and stopping, vibrations and impacts from an external machine, and changes in processing power over time.

## Nominal Life and Service Life in Hours

### Basic Dynamic Load Rating $C_a$

The basic dynamic load rating ( $C_a$ ) is used in calculations of service life for when the ball screw is under an axial load. The basic dynamic load rating ( $C_a$ ) indicates the load for which the nominal life  $L$  equals  $10^6$  (rev) when a group of identical ball screws independently operate under that load and it is applied with a constant direction and size. (The basic dynamic load ratings ( $C_a$ ) for each model number are indicated in the dimensional tables.)

### Nominal Life $L_{10m}$ (Total Rotations)

A ball screw's service life is obtained from the following formula using the basic dynamic load rating and applied axial load.

$$L_{10m} = \left( \frac{C_a}{f_w \cdot F_a} \right)^3 \times 10^6$$

$L$  : Modified nominal life (total rotations) (rev)

$C_a$  : Basic dynamic load rating\* (kN)

$F_a$  : Applied axial load (kN)

$f_w$  : Load factor

### Load Factor ( $f_w$ )

Vibration/impacts	Speed (V)	$f_w$
Minute	Under minute speeds $V \leq 0.25$ m/s	1.0 to 1.2
Low	Under low speeds $0.25$ m/s < $V \leq 1.0$ m/s	1.2 to 1.5
Medium	Under medium speeds $1.0$ m/s < $V \leq 2.0$ m/s	1.5 to 2.0
High	Under high speeds $2.0$ m/s < $V$	2.0 to 3.5

\*The nominal life is obtained by calculating the load on the premise that the product is set up in ideal mounting conditions with the assurance of good lubrication. The service life can be affected by the precision of the mounting materials used and any distortion.

### Service Life Time $L_h$

Once the nominal life ( $L_{10m}$ ) has been obtained, the service life in hours ( $L_h$ ) can be calculated using the following formula if the stroke length and the number of cycles are constant.

$$L_h = \frac{L_{10m} \times Ph}{2 \times l_s \times n \times 60}$$

$L_h$  : Service life time (h)

$l_s$  : Stroke length (mm)

$n$  : Number of cycles per minute (min<sup>-1</sup>)

$Ph$  : Lead (mm)

## Contamination Protection

If foreign materials enter the ball screw, they may lead to abnormal wear and ball jamming, which could shorten the life of the product. Therefore, it is necessary to prevent foreign material from entering the product. If it is likely that foreign materials will get inside, it is important to select an effective contamination protection device suited to the conditions in which it will be used.

### ■ Thin Film Seal (TT)

Thin film seals protect against foreign impurities and lubricant discharge through direct contact. They have low sliding resistance and generate little heat.

### ■ Canvas Seal (CC)

Canvas seals prevent foreign material from entering the nut through elastic contact with the outer diameter of the ball screw shaft and the groove. In addition to exceptional performance at preventing contamination and retaining grease, they are made from resin with high slidability and therefore generate little heat. They are used when higher levels of contamination protection are needed.

\*When canvas seals are applied, the overall nut length may become longer.  
For applicable models and their dimensions after applying seals, see p. 25.

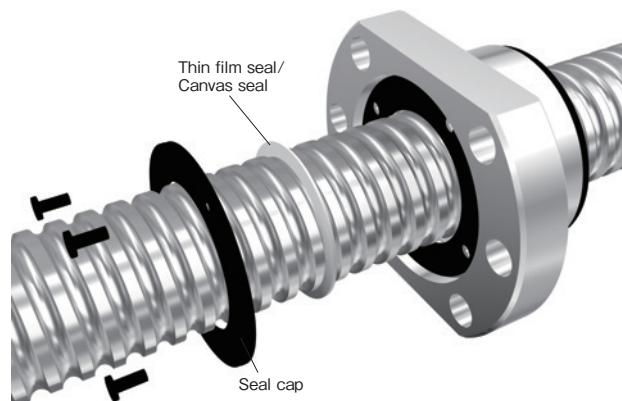

## Standard Grease

### THK Original Grease AFJ

AFJ grease uses refined mineral oil as its base and has a urea-based consistency enhancer and other special additives that give it excellent lubrication properties at a wide range of speeds from low to high.

\*The  $\phi 10$  is filled with lithium-based grease No. 2 (Multemp PS-2 grease) as standard.  
\*Non-standard greases are also available. Please contact THK.

### Representative Physical Properties

Item	Representative physical property	Testing method
Consistency enhancer	Urea-based	
Base oil	Refined mineral oil	
Base oil kinematic viscosity: mm <sup>2</sup> /s (40°C)	20	JIS K 2220 23
Worked penetration (25°C, 60 W)	325	JIS K 2220 7
Mixing stability (100,000 W)	360	JIS K 2220 15
Dropping point: °C	185	JIS K 2220 8
Evaporation volume: mass% (99°C, 22 h)	0.6	JIS K 2220 10
Oil separation rate: mass% (100°C, 24 h)	7.0	JIS K 2220 11
Copper plate corrosion (B method, 100°C, 24 h)	Passed	JIS K 2220 9
Low-temperature torque mN·m (-20°C)	Starting	38
	Rotational	13
4-ball testing (welding load): N	3089	ASTM D2596
Operating temperature range: °C	-20 to 120	
Color	Yellowish brown	

# SDA-V/SDAN-V

## Dimensional Table

### SDA-V/SDA-VZ

DN value	SDA-V (Caged Ball)	160000
	SDA-VZ (Full-Ball)	100000

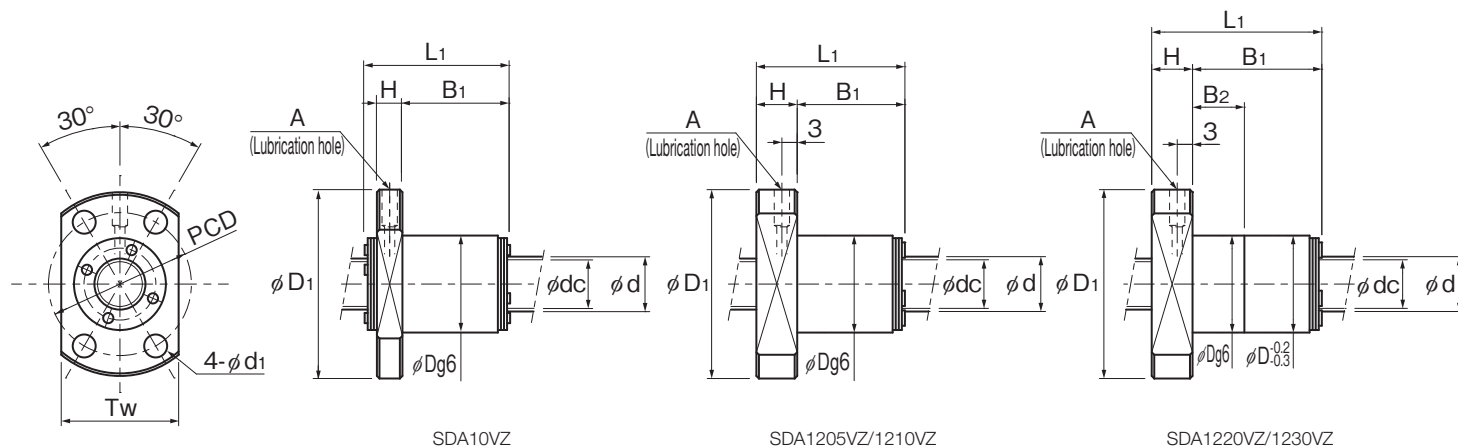

Model No.	Screw shaft outer diameter	Lead	Ball center-to-center diameter	Thread minor diameter	No. of loaded circuits	Basic load rating				Rigidity	
						SDA-V (Caged Ball)		SDA-VZ (Full-Ball)		SDA-V (Caged Ball)	SDA-VZ (Full-Ball)
						Ca (kN)	C <sub>0a</sub> (kN)	Ca (kN)	C <sub>0a</sub> (kN)	K (N/μm)	K (N/μm)
* SDA 1004VZ-4	10	4	10.4	8.77	1×4	-	-	3.54	5.42	-	143
* SDA 1005VZ-4	10	5	10.4	8.77	1×4	-	-	3.53	5.44	-	143
* SDA 1010VZ-3	10	10	10.4	8.77	1×3	-	-	2.63	3.86	-	108
* SDA 1205VZ-3	12	5	12.5	10.1	1×3	-	-	4.99	7.02	-	128
* SDA 1210VZ-2	12	10	12.5	10.1	1×2	-	-	3.31	4.25	-	83
* SDA 1220VZ-2	12	20	12.5	10.1	1×2	-	-	3.13	4.63	-	87
* SDA 1230VZ-2	12	30	12.5	10.1	1×2	-	-	2.92	4.14	-	91
SDA 1405V-4	14	5	14.5	12.1	1×4	7.4	10.1	7.1	11.3	178	196
SDA 1505V-3	15	5	15.5	13.1	1×3	5.9	7.9	5.6	8.8	140	153
SDA 1510V-3	15	10	15.5	13.1	1×3	5.8	7.6	5.5	8.4	141	154
SDA 1520V-4	15	20	15.5	13.1	2×2	6.8	10.1	6.5	11.2	181	198
SDA 1530V-4	15	30	15.5	13.1	2×2	6.5	8.8	6.2	9.7	188	205
SDA 1605V-3	16	5	16.5	14.1	1×3	6	8.4	5.8	9.4	147	162
SDA 1610V-3	16	10	16.5	14.1	1×3	6	8.1	5.7	9	148	163
SDA 1616V-3	16	16	16.5	14.1	1×3	5.9	8.4	5.6	9.2	151	165

Note: Models marked with an asterisk (\*) in the dimensional table are only compatible with the Model SDA-VZ (Full-Ball type).

## Model Number Coding

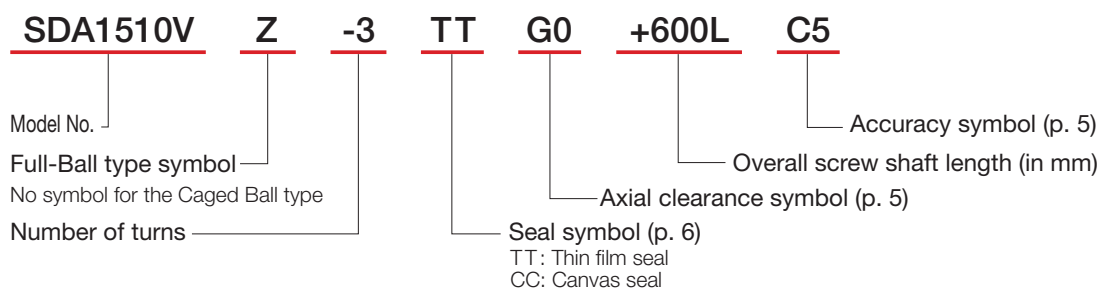

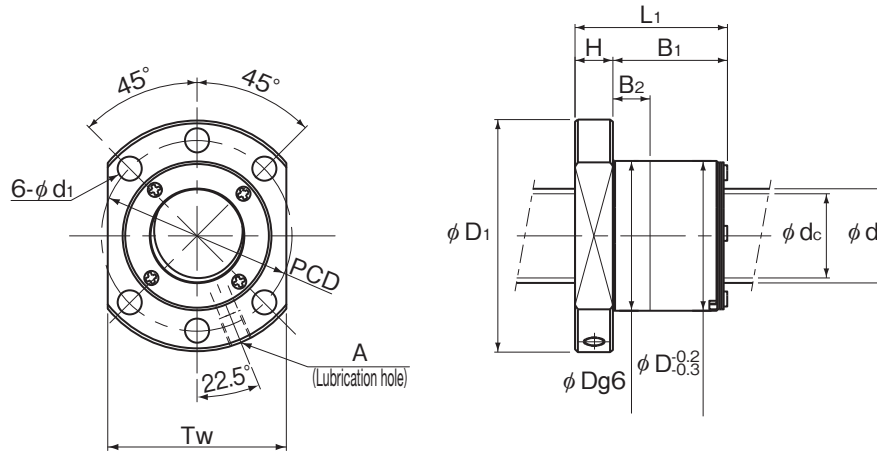

SDA14V to 16V

Unit: mm

	Nut dimensions										Screw shaft inertial moment/mm (kg·m <sup>2</sup> /mm)	Nut mass (kg)	Shaft mass (kg/m)	Permissible rotational speed	
	Outer diameter D	Flange diameter D <sub>1</sub>	Total length L <sub>1</sub>	H	B <sub>1</sub>	B <sub>2</sub>	PCD	d <sub>1</sub>	T <sub>w</sub>	Lubrication hole A				SDA-V (Caged Ball) (min <sup>-1</sup> )	SDA-VZ (Full-Ball) (min <sup>-1</sup> )
	19	36	24	6	16	-	28	4.5	23	φ3	7.71×10 <sup>-9</sup>	0.047	0.577	-	5000
	19	36	28	6	20	-	28	4.5	23	φ3	7.71×10 <sup>-9</sup>	0.052	0.585	-	5000
	19	36	37	6	29	-	28	4.5	23	φ3	7.71×10 <sup>-9</sup>	0.066	0.6	-	5000
	24	40	25	8	17	-	32	4.5	26	φ3	1.60×10 <sup>-8</sup>	0.073	0.796	-	5000
	24	40	29	8	21	-	32	4.5	26	φ3	1.60×10 <sup>-8</sup>	0.082	0.841	-	5000
	24	40	47	8	39	20	32	4.5	26	φ3	1.60×10 <sup>-8</sup>	0.126	0.863	-	5000
	24	40	65	8	57	20	32	4.5	26	φ3	1.60×10 <sup>-8</sup>	0.172	0.869	-	5000
	26	48	30	10	20	10	38	5.5	40	M6	2.96×10 <sup>-8</sup>	0.14	1.1	5000	5000
	28	48	25	10	15	12.5	38	5.5	40	M6	3.90×10 <sup>-8</sup>	0.13	1.27	5000	5000
	28	48	38	10	28	25.5	38	5.5	40	M6	3.90×10 <sup>-8</sup>	0.17	1.33	5000	5000
	28	48	46	10	36	20	38	5.5	40	M6	3.90×10 <sup>-8</sup>	0.19	1.33	5000	5000
	28	48	65	10	55	20	38	5.5	40	M6	3.90×10 <sup>-8</sup>	0.25	1.34	5000	5000
	28	48	25	10	15	12.5	38	5.5	40	M6	5.05×10 <sup>-8</sup>	0.13	1.46	5000	5000
	28	48	39	10	29	26.5	38	5.5	40	M6	5.05×10 <sup>-8</sup>	0.16	1.52	5000	5000
	28	48	56	10	46	20	38	5.5	40	M6	5.05×10 <sup>-8</sup>	0.21	1.54	5000	5000

Note: The groove on the screw shaft cannot be cut on both ends. Contact THK if you require such a design.

The rigidity values (K) in the table represent spring constants, each obtained from the load and the elastic deformation under an axial load equal to 30% of the basic axial dynamic load rating (Ca).

These values do not include the rigidity of the components related to mounting the ball screw nut. Therefore, it is generally appropriate to regard roughly 80% of the rigidity value (K) in the table as the actual value.

If the axial load (Fa) is not 0.3 Ca, the rigidity value (K<sub>N</sub>) is obtained from the following formula.

$$K_N = K \left( \frac{Fa}{0.3Ca} \right)^{\frac{1}{3}}$$

K: Rigidity value in the dimensional table

## Dimensional Table

### SDA-V

DN value	SDA-V (Caged Ball)	160000
	SDA-VZ (Full-Ball)	100000

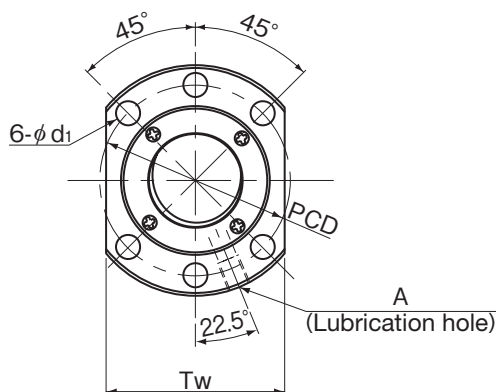

Model No.	Screw shaft outer diameter d	Lead Ph	Ball center-to-center diameter dp	Thread minor diameter dc	No. of loaded circuits Rows × turns	Basic load rating				Rigidity	
						SDA-V (Caged Ball)		SDA-VZ (Full-Ball)		SDA-V (Caged Ball)	SDA-VZ (Full-Ball)
						Ca (kN)	C <sub>0a</sub> (kN)	Ca (kN)	C <sub>0a</sub> (kN)	K (N/μm)	K (N/μm)
SDA 2004V-4	20	4	20.5	18.1	1×4	8.8	14.7	8.3	16.2	239	260
SDA 2005V-3	20	5	20.75	17.1	1×3	11.7	17.7	11.1	18.9	200	213
SDA 2006V-4	20	6	20.75	17.1	1×4	15.3	24.1	14.5	25.9	269	287
SDA 2010V-3	20	10	20.75	17.1	1×3	11.6	17.7	11	19	200	213
SDA 2010V-6	20	10	20.75	17.1	2×3	21	35.3	20	38.1	386	413
SDA 2020V-3	20	20	20.75	17.1	1×3	11.4	17.2	10.8	18.5	203	217
SDA 2020V-6	20	20	20.75	17.1	2×3	20.6	34.5	19.6	37	394	420
SDA 2030V-2	20	30	20.75	17.1	1×2	7.4	11.5	7	12.3	135	143
SDA 2040V-2	20	40	20.75	17.1	1×2	7.1	9.7	6.8	10.4	137	147
SDA 2060V-2	20	60	20.75	17.1	2×1	5.5	9.2	5.2	9.9	121	131
SDA 2505V-3	25	5	25.75	22.1	1×3	12.9	22	12.3	23.7	237	254
SDA 2510V-3	25	10	25.75	22.1	1×3	12.8	22	12.2	23.8	237	254
SDA 2520V-3	25	20	25.75	22.1	1×3	12.7	21.3	12.1	22.9	241	257
SDA 2525V-3	25	25	25.75	22.1	1×3	12.5	21.6	11.9	23.3	243	259
SDA 2530V-2	25	30	25.75	22.1	1×2	8.3	13.9	7.9	14.9	158	168
SDA 2530V-4	25	30	25.75	22.1	2×2	15.1	27.8	14.4	29.8	305	325
SDA 2550V-2	25	50	25.75	22.1	1×2	7.8	12.1	7.5	13.1	163	176

## Model Number Coding

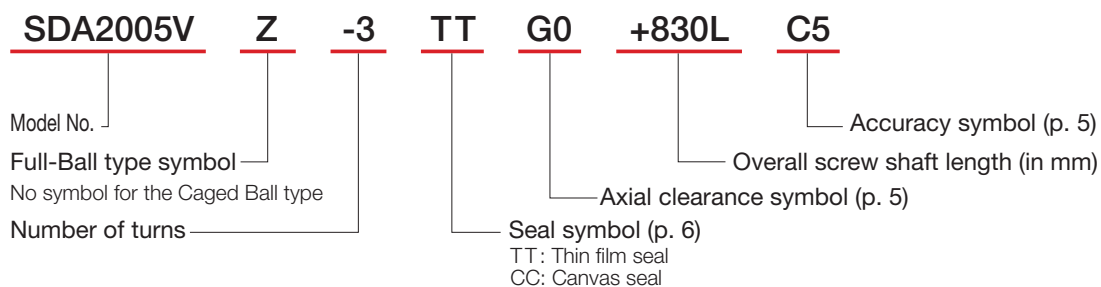

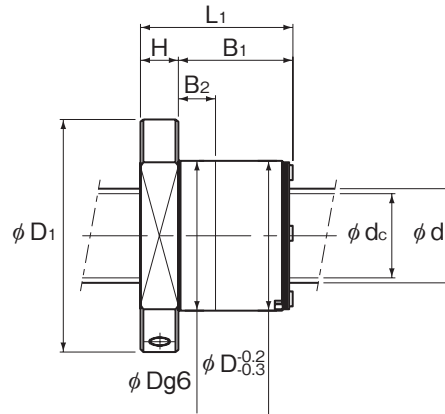

Unit: mm

	Nut dimensions										Screw shaft inertial moment/mm (kg·m <sup>2</sup> /mm)	Nut mass (kg)	Shaft mass (kg/m)	Permissible rotational speed		
	Outer diameter	Flange diameter	Total length	H	B <sub>1</sub>	B <sub>2</sub>	PCD	d <sub>1</sub>	T <sub>w</sub>	Lubrication hole				A	SDA-V (Caged Ball) (min <sup>-1</sup> )	SDA-VZ (Full-Ball) (min <sup>-1</sup> )
	D	D <sub>1</sub>	L <sub>1</sub>													
	32	58	27	10	17	14.5	47	6.6	44	M6	1.23×10 <sup>-7</sup>	0.17	2.27	5000	4870	
	36	58	27	10	17	13.5	47	6.6	44	M6	1.23×10 <sup>-7</sup>	0.18	2.21	5000	4810	
	36	58	35	10	25	22.2	47	6.6	44	M6	1.23×10 <sup>-7</sup>	0.22	2.23	5000	4810	
	36	58	40	10	30	27	47	6.6	44	M6	1.23×10 <sup>-7</sup>	0.25	2.34	5000	4810	
	36	58	40	10	30	27	47	6.6	44	M6	1.23×10 <sup>-7</sup>	0.25	2.18	5000	4810	
	36	58	67	10	57	20	47	6.6	44	M6	1.23×10 <sup>-7</sup>	0.39	2.4	5000	4810	
	36	58	67	10	57	20	47	6.6	44	M6	1.23×10 <sup>-7</sup>	0.38	2.31	5000	4810	
	36	58	66	10	56	20	47	6.6	44	M6	1.23×10 <sup>-7</sup>	0.38	2.42	5000	4810	
	36	58	84	10	74	20	47	6.6	44	M6	1.23×10 <sup>-7</sup>	0.47	2.43	5000	4810	
	36	58	63	10	53	20	47	6.6	44	M6	1.23×10 <sup>-7</sup>	0.36	2.39	5000	4810	
	40	62	27	10	17	13.5	51	6.6	48	M6	3.01×10 <sup>-7</sup>	0.2	3.53	5000	3880	
	40	62	40	10	30	27	51	6.6	48	M6	3.01×10 <sup>-7</sup>	0.28	3.7	5000	3880	
	40	62	67	10	57	20	51	6.6	48	M6	3.01×10 <sup>-7</sup>	0.42	3.78	5000	3880	
	40	62	82	10	72	20	51	6.6	48	M6	3.01×10 <sup>-7</sup>	0.5	3.79	5000	3880	
	40	62	66	10	56	20	51	6.6	48	M6	3.01×10 <sup>-7</sup>	0.41	3.8	5000	3880	
	40	62	66	10	56	20	51	6.6	48	M6	3.01×10 <sup>-7</sup>	0.41	3.71	5000	3880	
	40	62	102	10	92	20	51	6.6	48	M6	3.01×10 <sup>-7</sup>	0.61	3.83	5000	3880	

Note: The groove on the screw shaft cannot be cut on both ends. Contact THK if you require such a design.

The rigidity values (K) in the table represent spring constants, each obtained from the load and the elastic deformation under an axial load equal to 30% of the basic axial dynamic load rating (Ca).

These values do not include the rigidity of the components related to mounting the ball screw nut. Therefore, it is generally appropriate to regard roughly 80% of the rigidity value (K) in the table as the actual value.

If the axial load (Fa) is not 0.3 Ca, the rigidity value (K<sub>N</sub>) is obtained from the following formula.

$$K_N = K \left( \frac{Fa}{0.3Ca} \right)^{\frac{1}{3}}$$

K: Rigidity value in the dimensional table

## Dimensional Table

### SDA-V

DN value	SDA-V (Caged Ball)	160000
	SDA-VZ (Full-Ball)	130000

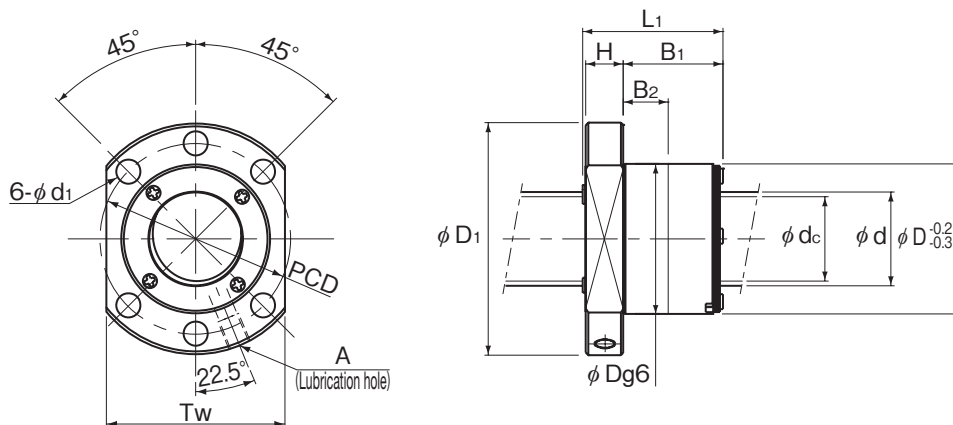

SDA28V to 32VA

Model No.	Screw shaft outer diameter	Lead	Ball center-to-center diameter	Thread minor diameter	No. of loaded circuits	Basic load rating				Rigidity	
						SDA-V (Caged Ball)		SDA-VZ (Full-Ball)		SDA-V (Caged Ball)	SDA-VZ (Full-Ball)
						Ca (kN)	C <sub>0a</sub> (kN)	Ca (kN)	C <sub>0a</sub> (kN)	K (N/μm)	K (N/μm)
SDA 2806V-5	28	6	29	24.9	1×5	29.6	54.5	28.2	57.7	462	487
SDA 3110V-5	31	10	32	25.4	1×5	57.1	94.7	54.4	99.7	529	554
SDA 3112V-5	31	12	32	25.4	1×5	57	94.7	54.3	99.9	529	555
SDA 3116V-5	31	16	32	25.4	1×5	56.8	96	54.1	100.5	534	556
SDA 3120V-5	31	20	32	25.4	1×5	56.6	90.3	53.9	95.1	533	558
SDA 3132V-2	31	32	32	25.4	1×2	23.2	33.8	22.1	35.4	206	214
SDA 3205V-4	32	5	32.75	29.1	1×4	18.8	38.5	17.9	41.7	388	416
SDA 3206V-5	32	6	33	28.9	1×5	31.4	62.4	29.9	66.1	513	541
SDA 3208V-5	32	8	33	28.9	1×5	31.4	62.4	29.9	66.2	513	541
SDA 3210V-5	32	10	33	28.9	1×5	31.3	62.9	29.8	66.3	517	541
SDA 3210VA-5	32	10	33	26.4	1×5	58.1	98.9	55.3	103.1	548	569
SDA 3212VA-5	32	12	33	26.4	1×5	58	98.9	55.3	103.3	548	569
SDA 3216VA-5	32	16	33	26.4	1×5	57.8	98.9	55.1	103.8	547	571
SDA 3220VA-5	32	20	33	26.4	1×5	57.6	94.3	54.9	98.2	552	572
SDA 3232VA-2	32	32	33	26.4	1×2	23.6	35.2	22.5	36.5	213	220
SDA 3610V-5	36	10	37	30.4	1×5	61.7	110.6	58.8	116.4	598	626
SDA 3612V-5	36	12	37	30.4	1×5	61.7	110.6	58.7	116.6	598	627
SDA 3616V-5	36	16	37	30.4	1×5	61.5	111.9	58.6	117.1	603	628
SDA 3620V-5	36	20	37	30.4	1×5	61.3	105.2	58.4	110.6	602	629
SDA 3636V-2	36	36	37	30.4	1×2	25.1	39.3	23.9	41.3	232	242

## Model Number Coding

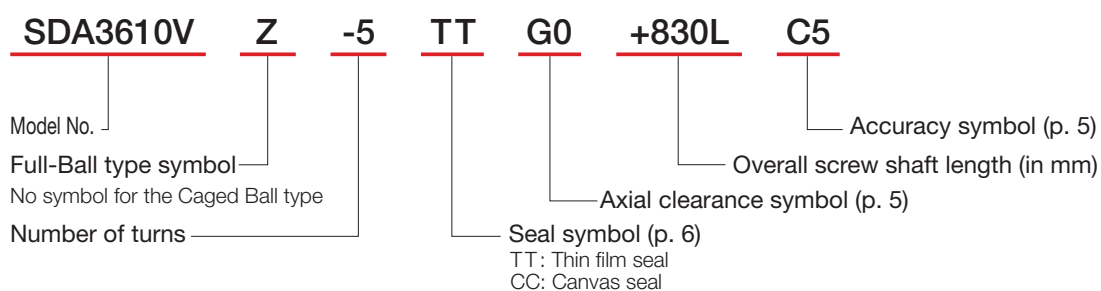

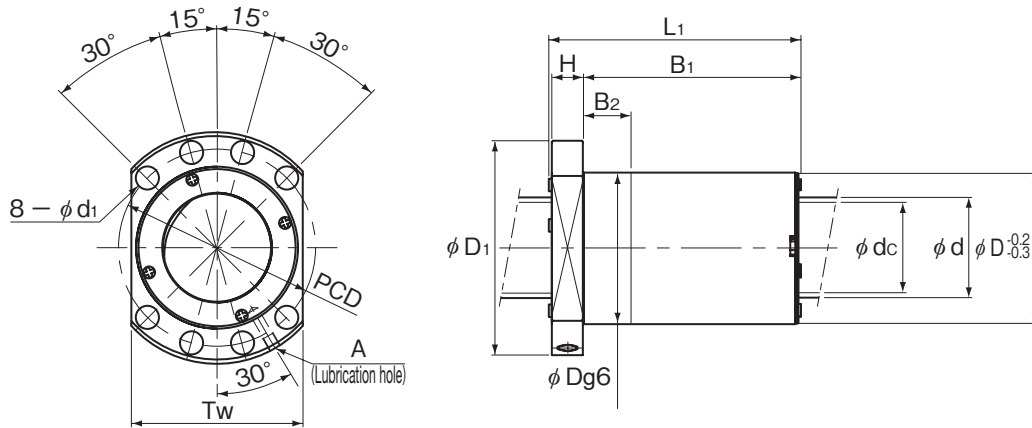

SDA36V

Unit: mm

	Nut dimensions										Screw shaft inertial moment/mm (kg·m <sup>2</sup> /mm)	Nut mass (kg)	Shaft mass (kg/m)	Permissible rotational speed	
	Outer diameter D	Flange diameter D <sub>1</sub>	Total length L <sub>1</sub>	H	B <sub>1</sub>	B <sub>2</sub>	PCD	d <sub>1</sub>	T <sub>w</sub>	Lubrication hole A				SDA-V (Caged Ball) (min <sup>-1</sup> )	SDA-VZ (Full-Ball) (min <sup>-1</sup> )
	46	80	42	12	30	27	65	9	62	M6	4.74×10 <sup>-7</sup>	0.49	4.37	5000	4480
	56	86	65	14	50	20	71	9	65	M6	7.07×10 <sup>-7</sup>	0.96	5.02	5000	4060
	56	86	74	14	59	20	71	9	65	M6	7.07×10 <sup>-7</sup>	1.08	5.17	5000	4060
	56	86	93	14	78	20	71	9	65	M6	7.07×10 <sup>-7</sup>	1.31	5.36	5000	4060
	56	86	112	14	97	20	71	9	65	M6	7.07×10 <sup>-7</sup>	1.54	5.47	5000	4060
	56	86	73	14	58	20	71	9	65	M6	7.07×10 <sup>-7</sup>	1.04	5.63	5000	4060
	50	80	32	12	20	17	65	9	62	M6	8.08×10 <sup>-7</sup>	0.41	5.89	4880	3960
	50	80	42	12	30	10	65	9	62	M6	8.08×10 <sup>-7</sup>	0.48	5.73	4840	3930
	50	80	52	12	40	20	65	9	62	M6	8.08×10 <sup>-7</sup>	0.56	5.87	4840	3930
	50	80	61	12	49	20	65	9	62	M6	8.08×10 <sup>-7</sup>	0.64	6	4840	3930
	57	87	65	14	50	20	72	9	66	M6	8.08×10 <sup>-7</sup>	0.98	5.38	4840	3930
	57	87	74	14	59	20	72	9	66	M6	8.08×10 <sup>-7</sup>	1.1	5.54	4840	3930
	57	87	93	14	78	20	72	9	66	M6	8.08×10 <sup>-7</sup>	1.34	5.73	4840	3930
	57	87	112	14	97	20	72	9	66	M6	8.08×10 <sup>-7</sup>	1.58	5.85	4840	3930
	57	87	73	14	58	20	72	9	66	M6	8.08×10 <sup>-7</sup>	1.07	6.01	4840	3930
	61	91	65	14	50	20	76	9	68	M8×1	1.29×10 <sup>-6</sup>	1.06	6.93	4320	3510
	61	91	74	14	59	20	76	9	68	M8×1	1.29×10 <sup>-6</sup>	1.19	7.11	4320	3510
	61	91	93	14	78	20	76	9	68	M8×1	1.29×10 <sup>-6</sup>	1.45	7.34	4320	3510
	61	91	112	14	97	20	76	9	68	M8×1	1.29×10 <sup>-6</sup>	1.7	7.47	4320	3510
	61	91	81	14	66	20	76	9	68	M8×1	1.29×10 <sup>-6</sup>	1.24	7.69	4320	3510

Note: The groove on the screw shaft cannot be cut on both ends. Contact THK if you require such a design.

The rigidity values (K) in the table represent spring constants, each obtained from the load and the elastic deformation under an axial load equal to 30% of the basic axial dynamic load rating (Ca).

These values do not include the rigidity of the components related to mounting the ball screw nut. Therefore, it is generally appropriate to regard roughly 80% of the rigidity value (K) in the table as the actual value.

If the axial load (Fa) is not 0.3 Ca, the rigidity value (K<sub>N</sub>) is obtained from the following formula.

$$K_N = K \left( \frac{Fa}{0.3Ca} \right)^{\frac{1}{3}}$$

K: Rigidity value in the dimensional table

## Dimensional Table

### SDA-V/SDA-VZ

DN value	SDA-V (Caged Ball)	160000
	SDA-VZ (Full-Ball)	130000

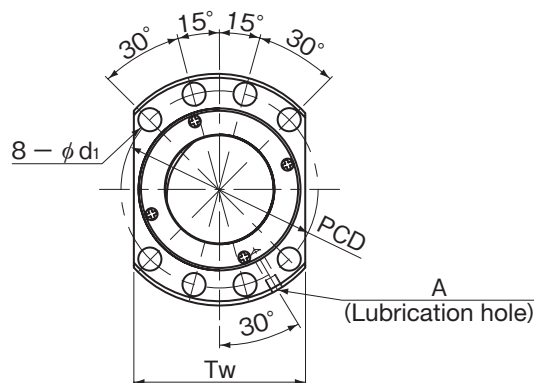

Model No.	Screw shaft outer diameter	Lead	Ball center-to-center diameter	Thread minor diameter	No. of loaded circuits	Basic load rating				Rigidity	
						SDA-V (Caged Ball)		SDA-VZ (Full-Ball)		SDA-V (Caged Ball)	SDA-VZ (Full-Ball)
						Ca (kN)	C <sub>0a</sub> (kN)	Ca (kN)	C <sub>0a</sub> (kN)	K (N/μm)	K (N/μm)
SDA 3810V-5	38	10	39	32.4	1×5	63.4	117.7	60.4	123.1	629	654
SDA 3812V-5	38	12	39	32.4	1×5	63.4	117.7	60.3	123.3	628	655
SDA 3815V-5	38	15	39	32.4	1×5	63.2	117.7	60.2	123.6	627	655
SDA 3816V-5	38	16	39	32.4	1×5	63.2	117.7	60.2	123.7	627	656
SDA 3820V-5	38	20	39	32.4	1×5	63	111.9	60	116.9	632	657
SDA 3825V-4	38	25	39	32.4	1×4	51.1	87.8	48.6	92.7	500	525
SDA 3830V-3	38	30	39	32.4	1×3	38.7	64.9	36.9	68.2	373	390
SDA 3840V-2	38	40	39	32.4	1×2	25.7	42	24.4	43.9	244	253
* SDA 4008VZ-5	40	8	41.25	36.4	1×5	-	-	42.2	99.4	-	663
SDA 4010VA-5	40	10	41.75	35.2	1×5	65.6	126.4	62.5	132.3	664	692
SDA 4012VA-5	40	12	41.75	35.2	1×5	65.5	126.4	62.4	132.5	664	692
SDA 4015VA-5	40	15	41.75	35.2	1×5	65.4	126.4	62.3	132.8	663	693
SDA 4016VA-5	40	16	41.75	35.2	1×5	65.4	126.4	62.3	132.9	663	693
SDA 4020VA-5	40	20	41.75	35.2	1×5	65.2	127.7	62.1	133.4	668	695
SDA 4020VA-10	40	20	41.75	35.2	2×5	118.4	254.1	112.8	266.9	1288	1345
SDA 4025VA-4	40	25	41.75	35.2	1×4	52.9	94.5	50.4	99.4	531	555
SDA 4030VA-3	40	30	41.75	35.2	1×3	40.1	70.3	38.2	73.1	398	412
SDA 4030VA-6	40	30	41.75	35.2	2×3	72.8	139.2	69.4	146.1	764	798
SDA 4040VA-2	40	40	41.75	35.2	1×2	26.6	44.7	25.4	46.9	256	267
SDA 4040VA-4	40	40	41.75	35.2	2×2	48.4	89.4	46.1	93.8	496	518

Note: Models marked with an asterisk (\*) in the dimensional table are only compatible with the Model SDA-VZ (Full-Ball type).

## Model Number Coding

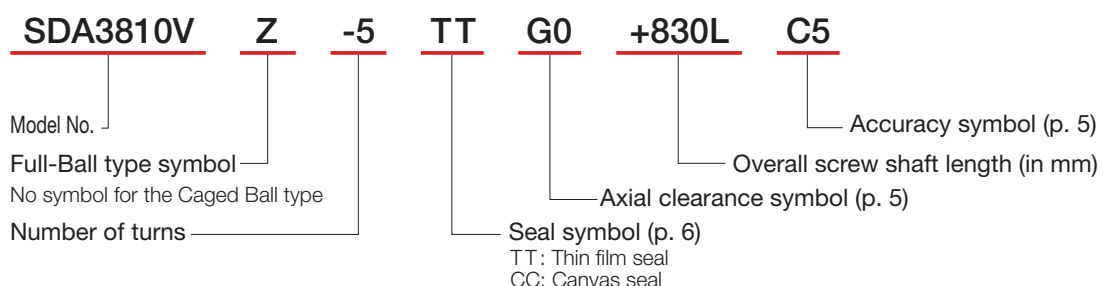

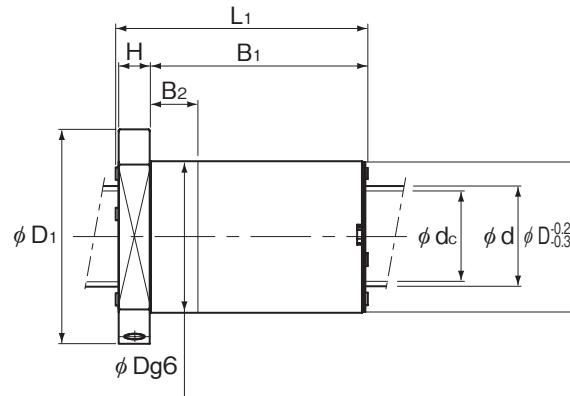

Unit: mm

	Nut dimensions										Screw shaft inertial moment/mm (kg·m <sup>2</sup> /mm)	Nut mass (kg)	Shaft mass (kg/m)	Permissible rotational speed				
	Outer diameter	Flange diameter	Total length	H	B <sub>1</sub>	B <sub>2</sub>	PCD	d <sub>1</sub>	T <sub>w</sub>	Lubrication hole				A			SDA-V (Caged Ball)	SDA-VZ (Full-Ball)
	D	D <sub>1</sub>	L <sub>1</sub>														(min <sup>-1</sup> )	(min <sup>-1</sup> )
	63	93	65	14	50	20	78	9	70	M8×1	1.60×10 <sup>-6</sup>	1.1	7.79	4100	3330			
	63	93	74	14	59	20	78	9	70	M8×1	1.60×10 <sup>-6</sup>	1.23	7.97	4100	3330			
	63	93	88	14	73	20	78	9	70	M8×1	1.60×10 <sup>-6</sup>	1.41	8.09	4100	3330			
	63	93	93	14	78	20	78	9	70	M8×1	1.60×10 <sup>-6</sup>	1.5	8.21	4100	3330			
	63	93	112	14	97	20	78	9	70	M8×1	1.60×10 <sup>-6</sup>	1.77	8.35	4100	3330			
	63	93	111	14	96	20	78	9	70	M8×1	1.60×10 <sup>-6</sup>	1.73	8.45	4100	3330			
	63	93	100	14	85	20	78	9	70	M8×1	1.60×10 <sup>-6</sup>	1.56	8.53	4100	3330			
	63	93	87	14	72	20	78	9	70	M8×1	1.60×10 <sup>-6</sup>	1.38	8.62	4100	3330			
	61	91	55	14	41	20	76	9	68	M8×1	1.97×10 <sup>-6</sup>	0.81	9.08	-	3150			
	70	100	65	14	50	20	85	9	75	M8×1	1.97×10 <sup>-6</sup>	1.38	8.9	3830	3110			
	70	100	74	14	59	20	85	9	75	M8×1	1.97×10 <sup>-6</sup>	1.55	9.06	3830	3110			
	70	100	88	14	74	20	85	9	75	M8×1	1.97×10 <sup>-6</sup>	1.79	9.14	3830	3110			
	70	100	93	14	78	20	85	9	75	M8×1	1.97×10 <sup>-6</sup>	1.9	9.27	3830	3110			
	70	100	112	14	97	20	85	9	75	M8×1	1.97×10 <sup>-6</sup>	2.25	9.39	3830	3110			
	70	100	112	14	97	20	85	9	75	M8×1	1.97×10 <sup>-6</sup>	2.22	8.81	3830	3110			
	70	100	112	14	97	20	85	9	75	M8×1	1.97×10 <sup>-6</sup>	2.22	9.49	3830	3110			
	70	100	101	14	86	20	85	9	75	M8×1	1.97×10 <sup>-6</sup>	2.01	9.55	3830	3110			
	70	100	101	14	86	20	85	9	75	M8×1	1.97×10 <sup>-6</sup>	1.97	9.13	3830	3110			
	70	100	88	14	73	20	85	9	75	M8×1	1.97×10 <sup>-6</sup>	1.77	9.63	3830	3110			
	70	100	88	14	73	20	85	9	75	M8×1	1.97×10 <sup>-6</sup>	1.75	9.29	3830	3110			

Note: The groove on the screw shaft cannot be cut on both ends. Contact THK if you require such a design.

The rigidity values (K) in the table represent spring constants, each obtained from the load and the elastic deformation under an axial load equal to 30% of the basic axial dynamic load rating (Ca).

These values do not include the rigidity of the components related to mounting the ball screw nut. Therefore, it is generally appropriate to regard roughly 80% of the rigidity value (K) in the table as the actual value.

If the axial load (Fa) is not 0.3 Ca, the rigidity value (K<sub>N</sub>) is obtained from the following formula.

$$K_N = K \left( \frac{F_a}{0.3C_a} \right)^{\frac{1}{3}}$$

K: Rigidity value in the dimensional table

## Dimensional Table

### SDA-V

DN value	SDA-V (Caged Ball)	160000
	SDA-VZ (Full-Ball)	130000

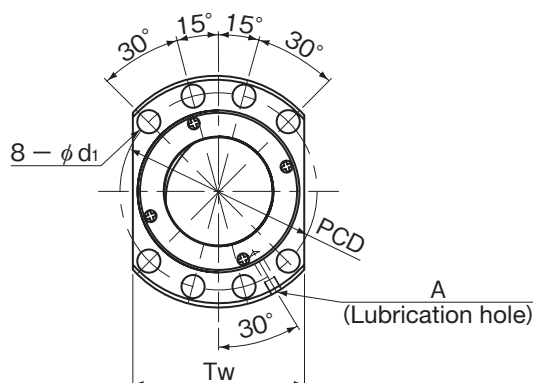

Model No.	Screw shaft outer diameter d	Lead Ph	Ball center-to-center diameter dp	Thread minor diameter dc	No. of loaded circuits Rows × turns	Basic load rating				Rigidity	
						SDA-V (Caged Ball)		SDA-VZ (Full-Ball)		SDA-V (Caged Ball)	SDA-VZ (Full-Ball)
						Ca (kN)	C <sub>0a</sub> (kN)	Ca (kN)	C <sub>0a</sub> (kN)	K (N/μm)	K (N/μm)
SDA 4510V-5	45	10	46	39.4	1×5	68.7	139.4	65.4	146.5	717	749
SDA 4510VA-5	45	10	46.75	40.2	1×5	69.2	142.2	65.9	149	729	759
SDA 4512V-5	45	12	46	39.4	1×5	68.6	139.4	65.4	146.7	717	750
SDA 4512VA-5	45	12	46.75	40.2	1×5	69.2	142.2	65.9	149.2	728	760
SDA 4516V-5	45	16	46	39.4	1×5	68.5	140.7	65.3	147	722	751
SDA 4516VA-5	45	16	46.75	40.2	1×5	69	142.2	65.8	149.5	727	761
SDA 4520V-5	45	20	46	39.4	1×5	68.4	140.7	65.1	147.5	721	752
SDA 4520VA-5	45	20	46.75	40.2	1×5	68.9	143.6	65.6	150	733	762
SDA 4520VA-10	45	20	46.75	40.2	2×5	125.1	285.8	119.1	300.1	1413	1475
SDA 4525V-4	45	25	46	39.4	1×4	55.5	104	52.8	109.8	572	600
SDA 4525VA-4	45	25	46.75	40.2	1×4	55.9	106.7	53.2	111.6	584	608
SDA 4530V-4	45	30	46	39.4	1×4	55.2	105.3	52.6	110.5	577	602
SDA 4530VA-4	45	30	46.75	40.2	1×4	55.7	106.7	53	112.3	583	610
SDA 4540V-3	45	40	46	39.4	1×3	41.7	78.3	39.7	81.9	431	449
SDA 4540VA-3	45	40	46.75	40.2	1×3	42.1	79.7	40.1	83.2	438	455

## Model Number Coding

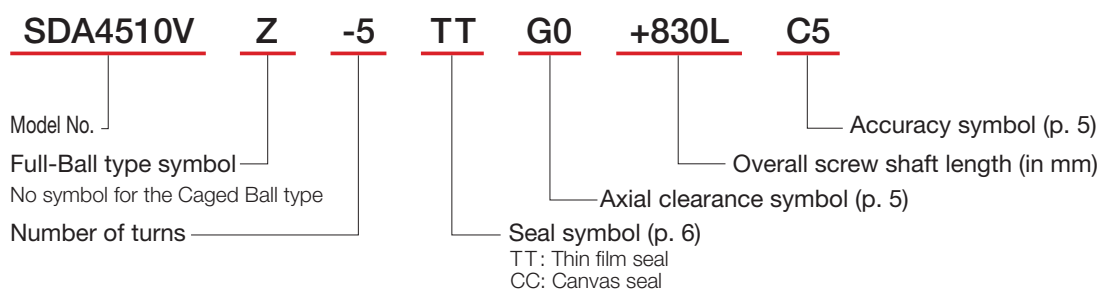

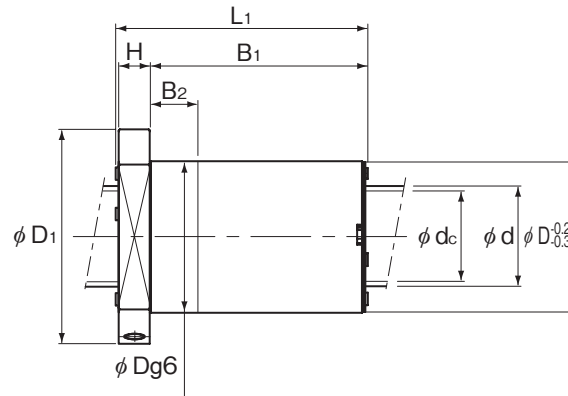

Unit: mm

	Nut dimensions										Screw shaft inertial moment/mm (kg·m <sup>2</sup> /mm)	Nut mass (kg)	Shaft mass (kg/m)	Permissible rotational speed	
	Outer diameter	Flange diameter	Total length	H	B <sub>1</sub>	B <sub>2</sub>	PCD	d <sub>1</sub>	T <sub>w</sub>	Lubrication hole				SDA-V (Caged Ball)	SDA-VZ (Full-Ball)
	D	D <sub>1</sub>	L <sub>1</sub>												
70	105	65	16	48	20	88	11	80	M8×1	3.16×10 <sup>-6</sup>	1.35	11.16	3470	2820	
75	110	65	16	48	20	93	11	85	M8×1	3.16×10 <sup>-6</sup>	1.62	11.4	3420	2780	
70	105	74	16	57	20	88	11	80	M8×1	3.16×10 <sup>-6</sup>	1.5	11.38	3470	2820	
75	110	74	16	57	20	93	11	85	M8×1	3.16×10 <sup>-6</sup>	1.81	11.58	3420	2780	
70	105	93	16	76	20	88	11	80	M8×1	3.16×10 <sup>-6</sup>	1.81	11.67	3470	2820	
75	110	93	16	76	20	93	11	85	M8×1	3.16×10 <sup>-6</sup>	2.19	11.82	3420	2780	
70	105	112	16	95	20	88	11	80	M8×1	3.16×10 <sup>-6</sup>	2.11	11.84	3470	2820	
75	110	112	16	95	20	93	11	85	M8×1	3.16×10 <sup>-6</sup>	2.57	11.96	3420	2780	
75	110	112	16	95	20	93	11	85	M8×1	3.16×10 <sup>-6</sup>	2.56	11.28	3420	2780	
70	105	110	16	93	20	88	11	80	M8×1	3.16×10 <sup>-6</sup>	2.04	11.95	3470	2820	
75	110	110	16	93	20	93	11	85	M8×1	3.16×10 <sup>-6</sup>	2.51	12.06	3420	2780	
70	105	130	16	113	20	88	11	80	M8×1	3.16×10 <sup>-6</sup>	2.36	12.04	3470	2820	
75	110	131	16	114	20	93	11	85	M8×1	3.16×10 <sup>-6</sup>	2.91	12.14	3420	2780	
70	105	129	16	112	20	88	11	80	M8×1	3.16×10 <sup>-6</sup>	2.33	12.16	3470	2820	
75	110	129	16	112	20	93	11	85	M8×1	3.16×10 <sup>-6</sup>	2.86	12.23	3420	2780	

Note: The groove on the screw shaft cannot be cut on both ends. Contact THK if you require such a design.

The rigidity values (K) in the table represent spring constants, each obtained from the load and the elastic deformation under an axial load equal to 30% of the basic axial dynamic load rating (Ca).

These values do not include the rigidity of the components related to mounting the ball screw nut. Therefore, it is generally appropriate to regard roughly 80% of the rigidity value (K) in the table as the actual value.

If the axial load (Fa) is not 0.3 Ca, the rigidity value (K<sub>N</sub>) is obtained from the following formula.

$$K_N = K \left( \frac{F_a}{0.3Ca} \right)^{\frac{1}{3}}$$

K: Rigidity value in the dimensional table

## Dimensional Table

### SDA-V

DN value	SDA-V (Caged Ball)	160000
	SDA-VZ (Full-Ball)	130000

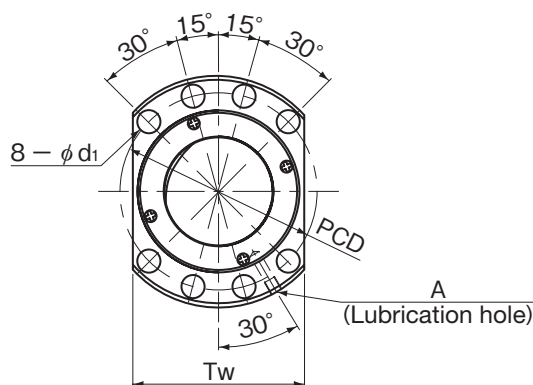

Model No.	Screw shaft outer diameter d	Lead Ph	Ball center-to-center diameter dp	Thread minor diameter dc	No. of loaded circuits Rows × turns	Basic load rating				Rigidity	
						SDA-V (Caged Ball)		SDA-VZ (Full-Ball)		SDA-V (Caged Ball)	SDA-VZ (Full-Ball)
						Ca (kN)	C <sub>0a</sub> (kN)	Ca (kN)	C <sub>0a</sub> (kN)	K (N/μm)	K (N/μm)
SDA 5010V-5	50	10	51	44.4	1×5	72	155.2	68.6	163.2	780	815
SDA 5010VA-5	50	10	51.75	45.2	1×5	72.5	158.1	69	165.7	791	825
SDA 5012V-5	50	12	51	44.4	1×5	72	155.2	68.5	163.3	779	816
SDA 5012VA-5	50	12	51.75	45.2	1×5	72.4	158.1	69	165.9	791	825
SDA 5016V-5	50	16	51	44.4	1×5	71.9	156.6	68.4	163.7	785	816
SDA 5016VA-5	50	16	51.75	45.2	1×5	72.3	158.1	68.9	166.2	790	826
SDA 5020V-5	50	20	51	44.4	1×5	71.7	156.6	68.3	164.2	784	817
SDA 5020V-10	50	20	51	44.4	2×5	130.2	313.2	124	328.3	1518	1583
SDA 5020VA-5	50	20	51.75	45.2	1×5	72.2	159.4	68.8	166.7	795	827
SDA 5020VA-10	50	20	51.75	45.2	2×5	131.1	317.5	124.8	333.3	1534	1602
SDA 5025V-4	50	25	51	44.4	1×4	58.2	123.6	55.5	129.8	624	652
SDA 5025VA-4	50	25	51.75	45.2	1×4	58.6	125.1	55.8	131.7	630	660
SDA 5025VA-8	50	25	51.75	45.2	2×4	106.4	251.5	101.3	263.5	1226	1277
SDA 5030V-4	50	30	51	44.4	1×4	58	117.5	55.3	122.6	629	654
SDA 5030VA-4	50	30	51.75	45.2	1×4	58.4	118.9	55.7	124.5	635	661
SDA 5030VA-8	50	30	51.75	45.2	2×4	106.1	237.7	101	248.9	1229	1280
SDA 5040V-3	50	40	51	44.4	1×3	43.9	86.5	41.8	90.7	467	487
SDA 5040VA-3	50	40	51.75	45.2	1×3	44.2	87.9	42.1	92	473	492
SDA 5040VA-6	50	40	51.75	45.2	2×3	80.3	175.7	76.4	184	916	954
SDA 5050V-2	50	50	51	44.4	1×2	29.2	55.5	27.8	58	303	316
SDA 5050VA-2	50	50	51.75	45.2	1×2	29.4	55.6	28	58.8	303	319

### Model Number Coding

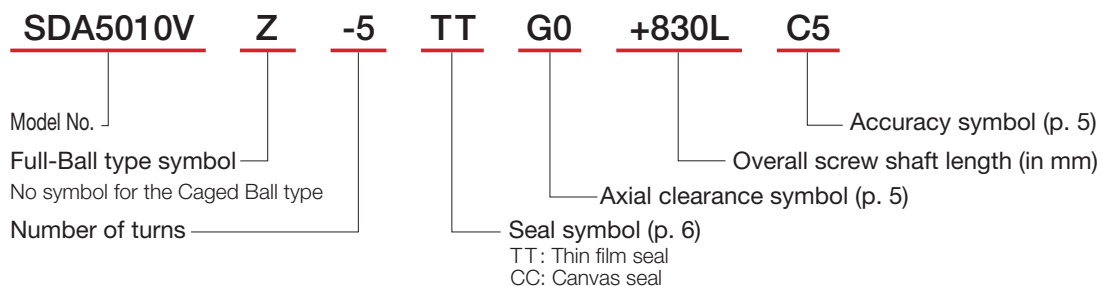

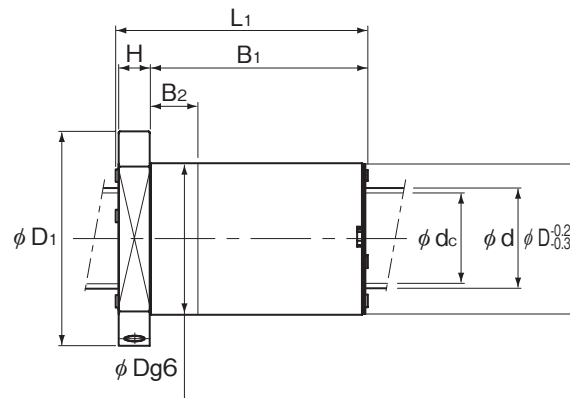

Unit: mm

Outer diameter D	Flange diameter D <sub>1</sub>	Total length L <sub>1</sub>	Nut dimensions							Lubrication hole A	Screw shaft inertial moment/mm (kg·m <sup>2</sup> /mm)	Nut mass (kg)	Shaft mass (kg/m)	Permissible rotational speed	
			H	B <sub>1</sub>	B <sub>2</sub>	PCD	d <sub>1</sub>	T <sub>w</sub>	SDA-V (Caged Ball)					SDA-VZ (Full-Ball)	
															(min <sup>-1</sup> )
75	110	65	16	48	20	93	11	85	M8×1	4.82×10 <sup>-6</sup>	1.46	13.93	3130	2540	
82	118	65	16	48	20	100	11	92	M8×1	4.82×10 <sup>-6</sup>	1.89	14.2	3090	2510	
75	110	74	16	57	20	93	11	85	M8×1	4.82×10 <sup>-6</sup>	1.63	14.19	3130	2540	
82	118	74	16	57	20	100	11	92	M8×1	4.82×10 <sup>-6</sup>	2.12	14.41	3090	2510	
75	110	93	16	76	20	93	11	85	M8×1	4.82×10 <sup>-6</sup>	1.96	14.5	3130	2540	
82	118	93	16	76	20	100	11	92	M8×1	4.82×10 <sup>-6</sup>	2.57	14.67	3090	2510	
75	110	112	16	95	20	93	11	85	M8×1	4.82×10 <sup>-6</sup>	2.29	14.69	3130	2540	
75	110	112	16	95	20	93	11	85	M8×1	4.82×10 <sup>-6</sup>	2.25	13.79	3130	2540	
82	118	112	16	95	20	100	11	92	M8×1	4.82×10 <sup>-6</sup>	3.02	14.83	3090	2510	
82	118	112	16	95	20	100	11	92	M8×1	4.82×10 <sup>-6</sup>	2.98	14.06	3090	2510	
75	110	110	16	93	20	93	11	85	M8×1	4.82×10 <sup>-6</sup>	2.22	14.82	3130	2540	
82	118	110	16	93	20	100	11	92	M8×1	4.82×10 <sup>-6</sup>	2.95	14.95	3090	2510	
82	118	110	16	93	20	100	11	92	M8×1	4.82×10 <sup>-6</sup>	2.92	14.31	3090	2510	
75	110	130	16	113	20	93	11	85	M8×1	4.82×10 <sup>-6</sup>	2.57	14.92	3130	2540	
82	118	130	16	113	20	100	11	92	M8×1	4.82×10 <sup>-6</sup>	3.42	15.03	3090	2510	
82	118	130	16	113	20	100	11	92	M8×1	4.82×10 <sup>-6</sup>	3.39	14.47	3090	2510	
75	110	128	16	111	20	93	11	85	M8×1	4.82×10 <sup>-6</sup>	2.52	15.06	3130	2540	
82	118	129	16	112	20	100	11	92	M8×1	4.82×10 <sup>-6</sup>	3.37	15.13	3090	2510	
82	118	129	16	112	20	100	11	92	M8×1	4.82×10 <sup>-6</sup>	3.32	14.68	3090	2510	
75	110	107	16	90	20	93	11	85	M8×1	4.82×10 <sup>-6</sup>	2.13	15.13	3130	2540	
82	118	107	16	90	20	100	11	92	M8×1	4.82×10 <sup>-6</sup>	2.84	15.2	3090	2510	

Note: The groove on the screw shaft cannot be cut on both ends. Contact THK if you require such a design.

The rigidity values (K) in the table represent spring constants, each obtained from the load and the elastic deformation under an axial load equal to 30% of the basic axial dynamic load rating (Ca).

These values do not include the rigidity of the components related to mounting the ball screw nut. Therefore, it is generally appropriate to regard roughly 80% of the rigidity value (K) in the table as the actual value.

If the axial load (Fa) is not 0.3 Ca, the rigidity value (K<sub>N</sub>) is obtained from the following formula.

$$K_N = K \left( \frac{Fa}{0.3Ca} \right)^{\frac{1}{3}}$$

K: Rigidity value in the dimensional table

# SDA-V/SDAN-V

## Dimensional Table

### SDAN-V/SDAN-VX

DN value	SDAN-V (Caged Ball)	160000
	SDAN-VX (Full-Ball)	130000

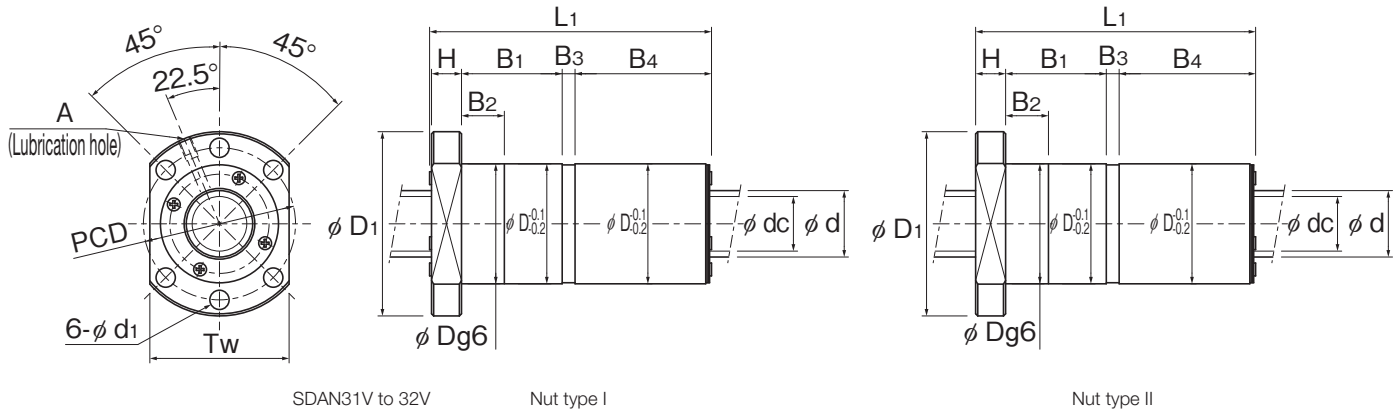

Model No.	Screw shaft outer diameter	Lead	Ball center-to-center diameter	Thread minor diameter	No. of loaded circuits	Basic load rating				Rigidity	
						SDAN-V (Caged Ball)		SDAN-VX (Full-Ball)		SDAN-V (Caged Ball)	SDAN-VX (Full-Ball)
						Ca (kN)	C <sub>0a</sub> (kN)	Ca (kN)	C <sub>0a</sub> (kN)	K (N/μm)	K (N/μm)
SDAN 3110V-5	31	10	32	25.4	1×5	57.1	94.7	54.4	99.7	1059	1108
SDAN 3112V-5	31	12	32	25.4	1×5	57	94.7	54.3	99.9	1058	1109
SDAN 3116V-5	31	16	32	25.4	1×5	56.8	96	54.1	100.5	1068	1112
SDAN 3120V-5	31	20	32	25.4	1×5	56.6	90.3	53.9	95.1	1065	1116
SDAN 3205V-4	32	5	32.75	29.5	1×4	18.8	38.5	17.9	41.7	776	832
SDAN 3206V-5	32	6	33	28.9	1×5	31.4	62.4	29.9	66.1	1027	1082
SDAN 3208V-5	32	8	33	28.9	1×5	31.4	62.4	29.9	66.2	1026	1082
SDAN 3210V-5	32	10	33	28.9	1×5	31.3	62.9	29.8	66.3	1033	1083
SDAN 3210VA-5	32	10	33	26.4	1×5	58.1	98.9	55.3	103.1	1097	1138
SDAN 3212VA-5	32	12	33	26.4	1×5	58	98.9	55.3	103.3	1096	1139
SDAN 3216VA-5	32	16	33	26.4	1×5	57.8	98.9	55.1	103.8	1094	1141
SDAN 3220VA-5	32	20	33	26.4	1×5	57.6	94.3	54.9	98.2	1104	1145
SDAN 3606V-4	36	6	37	32.9	1×4	26.9	55.6	25.6	58.6	902	945
SDAN 3610V-5	36	10	37	30.4	1×5	61.7	110.6	58.8	116.4	1196	1252
SDAN 3612V-5	36	12	37	30.4	1×5	61.7	110.6	58.7	116.6	1195	1253
SDAN 3616V-5	36	16	37	30.4	1×5	61.5	111.9	58.6	117.1	1206	1255
SDAN 3620V-5	36	20	37	30.4	1×5	61.3	105.2	58.4	110.6	1203	1258
SDAN 3810V-5	38	10	39	32.4	1×5	63.4	117.7	60.4	123.1	1257	1308
SDAN 3812V-5	38	12	39	32.4	1×5	63.4	117.7	60.3	123.3	1256	1309
SDAN 3816V-5	38	16	39	32.4	1×5	63.2	117.7	60.2	123.7	1254	1311
SDAN 3820V-5	38	20	39	32.4	1×5	63	111.9	60	116.9	1265	1314
* SDAN 4008VX-5	40	8	41.25	36.3	1×5	-	-	42.2	99.4	-	1326
SDAN 4010VA-5	40	10	41.75	35.2	1×5	65.6	126.4	62.5	132.3	1329	1384
SDAN 4012VA-5	40	12	41.75	35.2	1×5	65.5	126.4	62.4	132.5	1328	1385
SDAN 4016VA-5	40	16	41.75	35.2	1×5	65.4	126.4	62.3	132.9	1326	1387
SDAN 4020VA-5	40	20	41.75	35.2	1×5	65.2	127.7	62.1	133.4	1336	1389

Note: Models marked with an asterisk (\*) in the dimensional table are only compatible with the Model SDAN-VX (Full-Ball type).

## Model Number Coding

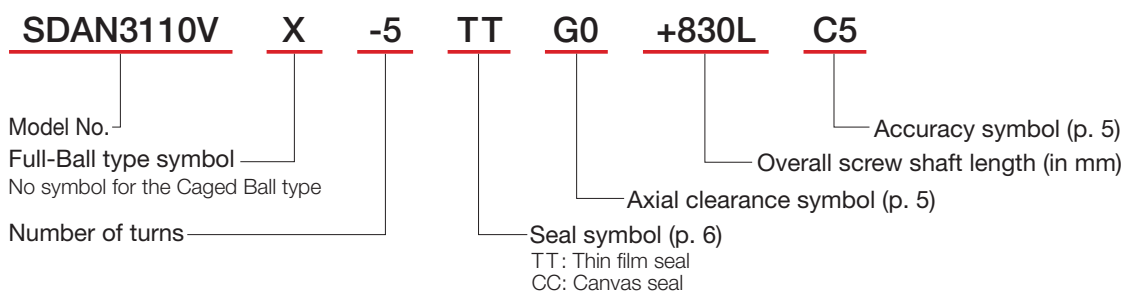

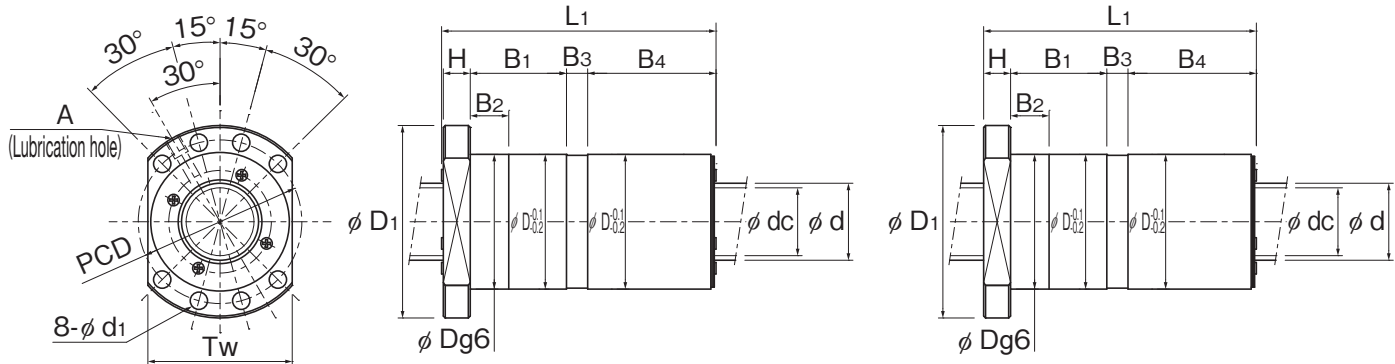

SDAN36V to 40V

Nut type I

Nut type II

Unit: mm

Nut type	Nut dimensions												Lubrication hole	Screw shaft inertial moment/mm <sup>2</sup>	Nut mass	Shaft mass	Permissible rotational speed	
	Outer diameter D	Flange diameter D <sub>1</sub>	Total length L <sub>1</sub>	H	B <sub>1</sub>	B <sub>2</sub>	Shim plate thickness B <sub>3</sub>	B <sub>4</sub>	PCD	d <sub>1</sub>	T <sub>w</sub>	SDAN-V (Caged Ball)					SDAN-VX (Full-Ball)	
I	56	86	135	14	47	20	11	62	71	9	65	M6	7.07×10 <sup>-7</sup>	1.83	5.02	5000	4060	
I	56	86	158	14	56	20	15.6	72	71	9	65	M6	7.07×10 <sup>-7</sup>	2.1	5.17	5000	4060	
I	56	86	189	14	75	20	8.9	90	71	9	65	M6	7.07×10 <sup>-7</sup>	2.5	5.36	5000	4060	
I	56	86	232	14	94	20	14.1	109	71	9	65	M6	7.07×10 <sup>-7</sup>	3.01	5.48	5000	4060	
II	50	80	62	12	16.5	16.5	4.5	29	65	9	62	M6	8.08×10 <sup>-7</sup>	0.66	5.89	4880	3960	
II	50	80	84	12	27.2	27.2	5.8	39	65	9	62	M6	8.08×10 <sup>-7</sup>	0.85	5.79	4840	3930	
II	50	80	108	12	37	20	10.4	49	65	9	62	M6	8.08×10 <sup>-7</sup>	1.03	5.87	4840	3930	
II	50	80	121	12	46	20	5	58	65	9	62	M6	8.08×10 <sup>-7</sup>	1.17	6	4840	3930	
I	57	87	135	14	47	20	11	62	72	9	66	M6	8.08×10 <sup>-7</sup>	1.87	5.38	4840	3930	
I	57	87	158	14	56	20	15.6	72	72	9	66	M6	8.08×10 <sup>-7</sup>	2.14	5.54	4840	3930	
I	57	87	189	14	75	20	8.7	90	72	9	66	M6	8.08×10 <sup>-7</sup>	2.56	5.73	4840	3930	
I	57	87	232	14	94	20	13.9	109	72	9	66	M6	8.08×10 <sup>-7</sup>	3.08	5.85	4840	3930	
II	54	84	72	14	19.2	19.2	5.8	33	69	9	66	M6	1.29×10 <sup>-6</sup>	0.84	7.4	4320	3510	
I	61	91	135	14	47	20	11	62	76	9	68	M8×1	1.29×10 <sup>-6</sup>	2	6.93	4320	3510	
I	61	91	158	14	56	20	15.6	72	76	9	68	M8×1	1.29×10 <sup>-6</sup>	2.31	7.11	4320	3510	
I	61	91	189	14	75	20	8.8	90	76	9	68	M8×1	1.29×10 <sup>-6</sup>	2.77	7.34	4320	3510	
I	61	91	232	14	94	20	14	109	76	9	68	M8×1	1.29×10 <sup>-6</sup>	3.33	7.47	4320	3510	
I	63	93	135	14	47	20	11.1	62	78	9	70	M8×1	1.60×10 <sup>-6</sup>	2.08	7.79	4100	3330	
I	63	93	158	14	56	20	15.7	71	78	9	70	M8×1	1.60×10 <sup>-6</sup>	2.4	7.97	4100	3330	
I	63	93	189	14	75	20	8.9	90	78	9	70	M8×1	1.60×10 <sup>-6</sup>	2.89	8.21	4100	3330	
I	63	93	232	14	94	20	14.2	109	78	9	70	M8×1	1.60×10 <sup>-6</sup>	3.44	8.35	4100	3330	
II	61	91	111	14	38	20	7.4	52	76	9	68	M8×1	1.97×10 <sup>-6</sup>	1.47	9.08	-	3150	
I	70	100	135	14	47	20	10.9	62	85	9	75	M8×1	1.97×10 <sup>-6</sup>	2.68	8.9	3830	3110	
I	70	100	158	14	56	20	15.5	72	85	9	75	M8×1	1.97×10 <sup>-6</sup>	3.1	9.06	3830	3110	
I	70	100	189	14	75	20	8.7	90	85	9	75	M8×1	1.97×10 <sup>-6</sup>	3.7	9.27	3830	3110	
I	70	100	232	14	94	20	13.9	109	85	9	75	M8×1	1.97×10 <sup>-6</sup>	4.45	9.39	3830	3110	

Note: The groove on the screw shaft cannot be cut on both ends. Contact THK if you require such a design.

The rigidity values in the table represent spring constants, each obtained from the load and the elastic deformation when providing a preload equal to 10% of the basic axial dynamic load rating (Ca) and applying an axial load three times greater than the preload. These values do not include the rigidity of the components related to mounting the ball screw nut. Therefore, it is normally appropriate to regard roughly 80% of the value in the table as the actual value. If the applied preload (Fa<sub>0</sub>) is not 0.1 Ca, the rigidity value (K<sub>N</sub>) is obtained from the following formula.

$$K_N = K \left( \frac{Fa_0}{0.1Ca} \right)^{\frac{1}{3}}$$

K: Rigidity value in the dimensional table

## Dimensional Table

### SDAN-V

DN value	SDAN-V (Caged Ball)	160000
	SDAN-VX (Full-Ball)	130000

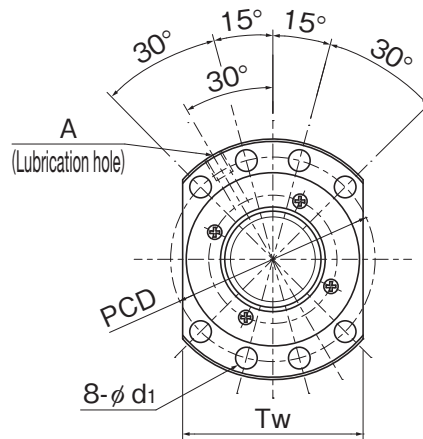

Model No.	Screw shaft outer diameter	Lead	Ball center-to-center diameter	Thread minor diameter	No. of loaded circuits	Basic load rating				Rigidity	
						SDAN-V (Caged Ball)		SDAN-VX (Full-Ball)		SDAN-V (Caged Ball)	SDAN-VX (Full-Ball)
						Ca (kN)	C <sub>0a</sub> (kN)	Ca (kN)	C <sub>0a</sub> (kN)	K (N/μm)	K (N/μm)
	d	Ph	dp	dc	Rows × turns						
SDAN 4510V-5	45	10	46	39.4	1×5	68.7	139.4	65.4	146.5	1434	1499
SDAN 4510VA-5	45	10	46.75	40.2	1×5	69.2	142.2	65.9	149	1457	1519
SDAN 4512V-5	45	12	46	39.4	1×5	68.6	139.4	65.4	146.7	1433	1500
SDAN 4512VA-5	45	12	46.75	40.2	1×5	69.2	142.2	65.9	149.2	1457	1519
SDAN 4516V-5	45	16	46	39.4	1×5	68.5	140.7	65.3	147	1444	1501
SDAN 4516VA-5	45	16	46.75	40.2	1×5	69	142.2	65.8	149.5	1455	1521
SDAN 4520V-5	45	20	46	39.4	1×5	68.4	140.7	65.1	147.5	1442	1504
SDAN 4520VA-5	45	20	46.75	40.2	1×5	68.9	143.6	65.6	150	1465	1524
SDAN 5010V-5	50	10	51	44.4	1×5	72	155.2	68.6	163.2	1559	1630
SDAN 5010VA-5	50	10	51.75	45.2	1×5	72.5	158.1	69	165.7	1582	1650
SDAN 5012V-5	50	12	51	44.4	1×5	72	155.2	68.5	163.3	1559	1631
SDAN 5012VA-5	50	12	51.75	45.2	1×5	72.4	158.1	69	165.9	1582	1651
SDAN 5016V-5	50	16	51	44.4	1×5	71.9	156.6	68.4	163.7	1570	1633
SDAN 5016VA-5	50	16	51.75	45.2	1×5	72.3	158.1	68.9	166.2	1580	1652
SDAN 5020V-5	50	20	51	44.4	1×5	71.7	156.6	68.3	164.2	1568	1635
SDAN 5020VA-5	50	20	51.75	45.2	1×5	72.2	159.4	68.8	166.7	1591	1654
SDAN 5025V-4	50	25	51	44.4	1×4	58.2	123.6	55.5	129.8	1249	1304
SDAN 5025VA-4	50	25	51.75	45.2	1×4	58.6	125.1	55.8	131.7	1260	1319
SDAN 5030V-4	50	30	51	44.4	1×4	58	117.5	55.3	122.6	1258	1307
SDAN 5030VA-4	50	30	51.75	45.2	1×4	58.4	118.9	55.7	124.5	1269	1322
SDAN 5040V-3	50	40	51	44.4	1×3	43.9	86.5	41.8	90.7	934	974
SDAN 5040VA-3	50	40	51.75	45.2	1×3	44.2	87.9	42.1	92	946	985

### Model Number Coding

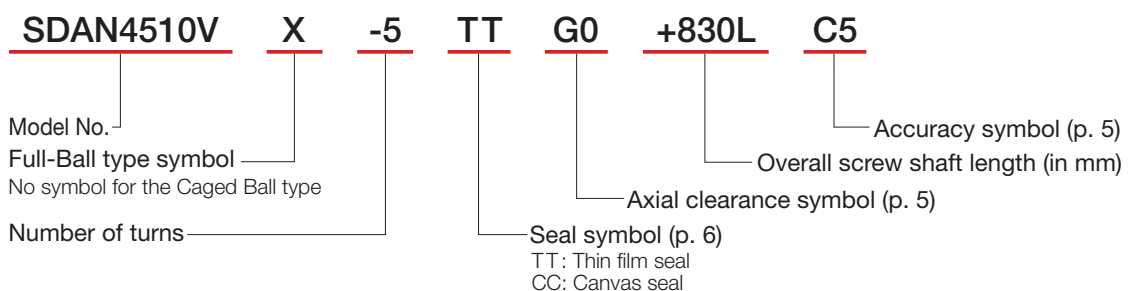

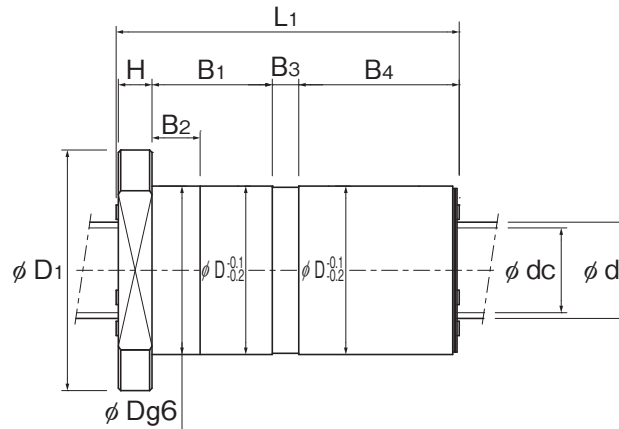

Unit: mm

	Nut dimensions												Screw shaft inertial moment/mm <sup>2</sup>	Nut mass (kg)	Shaft mass (kg/m)	Permissible rotational speed						
	Outer diameter	Flange diameter	Total length	H	B <sub>1</sub>	B <sub>2</sub>	Shim plate thickness	B <sub>3</sub>	B <sub>4</sub>	PCD	d <sub>1</sub>	T <sub>w</sub>				Lubrication hole	A	(kg·m <sup>2</sup> /mm)	(kg)	(kg/m)	SDAN-V (Caged Ball)	SDAN-VX (Full-Ball)
	D	D <sub>1</sub>	L <sub>1</sub>																		(min <sup>-1</sup> )	(min <sup>-1</sup> )
70	105	135	16	45	20	11	62	88	11	80	M8×1	3.16×10 <sup>-6</sup>	2.47	11.16	3470	2820						
75	110	135	16	45	20	11	62	93	11	85	M8×1	3.16×10 <sup>-6</sup>	3.05	11.4	3420	2780						
70	105	158	16	54	20	15.6	72	88	11	80	M8×1	3.16×10 <sup>-6</sup>	2.84	11.38	3470	2820						
75	110	158	16	54	20	15.6	72	93	11	85	M8×1	3.16×10 <sup>-6</sup>	3.5	11.58	3420	2780						
70	105	189	16	73	20	8.8	90	88	11	80	M8×1	3.16×10 <sup>-6</sup>	3.36	11.67	3470	2820						
75	110	189	16	73	20	8.8	90	93	11	85	M8×1	3.16×10 <sup>-6</sup>	4.15	11.82	3420	2780						
70	105	232	16	92	20	14	109	88	11	80	M8×1	3.16×10 <sup>-6</sup>	4.03	11.84	3470	2820						
75	110	232	16	92	20	14	109	93	11	85	M8×1	3.16×10 <sup>-6</sup>	5	11.96	3420	2780						
75	110	135	16	45	20	11	62	93	11	85	M8×1	4.82×10 <sup>-6</sup>	2.69	13.93	3130	2540						
82	118	135	16	45	20	11	62	100	11	92	M8×1	4.82×10 <sup>-6</sup>	3.58	14.2	3090	2510						
75	110	158	16	54	20	15.6	72	93	11	85	M8×1	4.82×10 <sup>-6</sup>	3.08	14.19	3130	2540						
82	118	158	16	54	20	15.6	72	100	11	92	M8×1	4.82×10 <sup>-6</sup>	4.12	14.41	3090	2510						
75	110	189	16	73	20	8.8	90	93	11	85	M8×1	4.82×10 <sup>-6</sup>	3.65	14.5	3130	2540						
82	118	189	16	73	20	8.8	90	100	11	92	M8×1	4.82×10 <sup>-6</sup>	4.89	14.67	3090	2510						
75	110	232	16	92	20	14	109	93	11	85	M8×1	4.82×10 <sup>-6</sup>	4.39	14.69	3130	2540						
82	118	232	16	92	20	14	109	100	11	92	M8×1	4.82×10 <sup>-6</sup>	5.89	14.83	3090	2510						
75	110	235	16	90	20	20.5	108	93	11	85	M8×1	4.82×10 <sup>-6</sup>	4.41	14.82	3130	2540						
82	118	235	16	90	20	20.5	108	100	11	92	M8×1	4.82×10 <sup>-6</sup>	5.93	14.95	3090	2510						
75	110	265	16	110	20	10.7	128	93	11	85	M8×1	4.82×10 <sup>-6</sup>	4.96	14.92	3130	2540						
82	118	265	16	110	20	10.6	128	100	11	92	M8×1	4.82×10 <sup>-6</sup>	6.67	15.03	3090	2510						
75	110	268	16	108	20	17.5	126	93	11	85	M8×1	4.82×10 <sup>-6</sup>	4.98	15.06	3130	2540						
82	118	269	16	108	20	17.3	126	100	11	92	M8×1	4.82×10 <sup>-6</sup>	6.72	15.13	3090	2510						

Note: The groove on the screw shaft cannot be cut on both ends. Contact THK if you require such a design.

The rigidity values in the table represent spring constants, each obtained from the load and the elastic deformation when providing a preload equal to 10% of the basic axial dynamic load rating (Ca) and applying an axial load three times greater than the preload.

These values do not include the rigidity of the components related to mounting the ball screw nut. Therefore, it is normally appropriate to regard roughly 80% of the value in the table as the actual value.

If the applied preload (Fa<sub>0</sub>) is not 0.1 Ca, the rigidity value (K<sub>N</sub>) is obtained from the following formula.

$$K_N = K \left( \frac{Fa_0}{0.1Ca} \right)^{\frac{1}{3}}$$

K: Rigidity value in the dimensional table

## Dimensional Table

### SDAN-VX

DN value	SDAN-VX (Full-Ball)	130000
----------	---------------------	--------

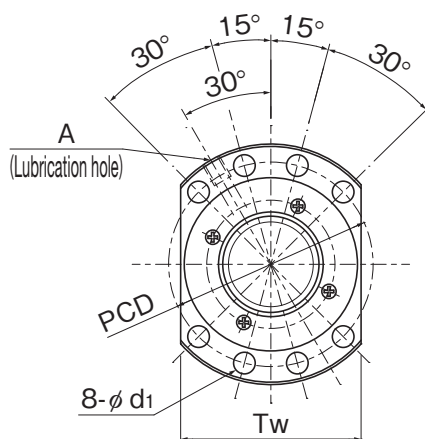

Model No.	Screw shaft outer diameter	Lead	Ball center-to-center diameter	Thread minor diameter	No. of loaded circuits	Basic load rating				Rigidity	
						SDAN-V (Caged Ball)		SDAN-VX (Full-Ball)		SDAN-V (Caged Ball)	SDAN-VX (Full-Ball)
						Ca (kN)	C <sub>0a</sub> (kN)	Ca (kN)	C <sub>0a</sub> (kN)	K (N/μm)	K (N/μm)
* SDAN 5510VX-4	55	10	56	49.4	1×4	-	-	58.2	141.6	-	1400
* SDAN 5510VAX-4	55	10	56.75	50.2	1×4	-	-	58.5	143.6	-	1416
* SDAN 5512VX-4	55	12	56	49.4	1×4	-	-	58.1	141.7	-	1401
* SDAN 5512VAX-4	55	12	56.75	50.2	1×4	-	-	58.5	143.7	-	1416
* SDAN 5516VX-4	55	16	56	49.4	1×4	-	-	58.1	142	-	1402
* SDAN 5516VAX-4	55	16	56.75	50.2	1×4	-	-	58.4	144	-	1417
* SDAN 5520VX-4	55	20	56	49.4	1×4	-	-	58	142.3	-	1403
* SDAN 5520VAX-4	55	20	56.75	50.2	1×4	-	-	58.3	144.3	-	1419
* SDAN 6310VX-4	63	10	64	57.4	1×4	-	-	61.6	162.7	-	1560
* SDAN 6312VX-4	63	12	65	57.6	1×4	-	-	72.9	185.2	-	1603
* SDAN 6316VX-4	63	16	65	57.6	1×4	-	-	72.8	185.5	-	1604
* SDAN 6320VX-4	63	20	65	57.6	1×4	-	-	72.7	185.8	-	1606
* SDAN 6325VX-4	63	25	65	57.6	1×4	-	-	72.6	186.3	-	1607
* SDAN 6330VX-4	63	30	65	57.6	1×4	-	-	72.5	186.9	-	1610
* SDAN 6340VX-3	63	40	65	57.6	1×3	-	-	55	129.2	-	1197

Note: Models marked with an asterisk (\*) in the dimensional table are only compatible with the Model SDAN-VX (Full-Ball type).

## Model Number Coding

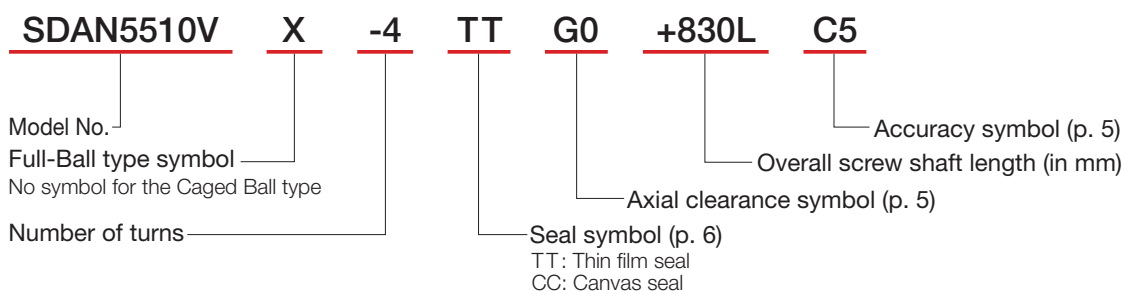

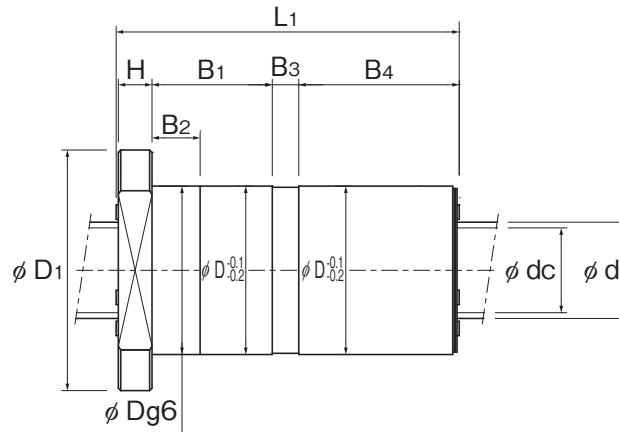

Unit: mm

Outer diameter	Nut dimensions											Screw shaft inertial moment/mm <sup>3</sup>	Nut mass (kg)	Shaft mass (kg/m)	Permissible rotational speed			
	Flange diameter	Total length	H	B <sub>1</sub>	B <sub>2</sub>	Shim plate thickness	B <sub>3</sub>	B <sub>4</sub>	PCD	d <sub>1</sub>	T <sub>w</sub>				Lubrication hole	A	SDAN-V (Caged Ball)	SDAN-VX (Full-Ball)
80	118	115	18	33	20	11	52	100	11	92	M8×1	7.05×10 <sup>-6</sup>	2.54	17.02	-	2320		
82	120	115	18	33	20	11	52	102	11	94	M8×1	7.05×10 <sup>-6</sup>	2.73	17.32	-	2290		
80	118	134	18	40	20	15.6	60	100	11	92	M8×1	7.05×10 <sup>-6</sup>	2.89	17.3	-	2320		
82	120	134	18	40	20	15.6	60	102	11	94	M8×1	7.05×10 <sup>-6</sup>	3.11	17.55	-	2290		
80	118	157	18	55	20	8.8	74	100	11	92	M8×1	7.05×10 <sup>-6</sup>	3.35	17.65	-	2320		
82	120	157	18	55	20	8.8	74	102	11	94	M8×1	7.05×10 <sup>-6</sup>	3.6	17.84	-	2290		
80	118	192	18	70	20	14	89	100	11	92	M8×1	7.05×10 <sup>-6</sup>	4	17.86	-	2320		
82	120	192	18	70	20	14	89	102	11	94	M8×1	7.05×10 <sup>-6</sup>	4.3	18.01	-	2290		
90	125	115	18	33	20	11	52	108	11	95	M8×1	1.21×10 <sup>-5</sup>	2.97	22.61	-	2030		
95	135	135	20	39	25	14.6	61	115	13.5	100	M8×1	1.21×10 <sup>-5</sup>	4.18	22.89	-	2000		
95	135	158	20	54	25	7.8	75	115	13.5	100	M8×1	1.21×10 <sup>-5</sup>	4.84	23.3	-	2000		
95	135	193	20	69	25	13	90	115	13.5	100	M8×1	1.21×10 <sup>-5</sup>	5.8	23.55	-	2000		
95	135	237	20	88	25	19.3	109	115	13.5	100	M8×1	1.21×10 <sup>-5</sup>	7.02	23.74	-	2000		
95	135	266	20	107	25	10.2	128	115	13.5	100	M8×1	1.21×10 <sup>-5</sup>	7.84	23.87	-	2000		
95	135	269	20	105	25	17.2	126	115	13.5	100	M8×1	1.21×10 <sup>-5</sup>	7.87	24.04	-	2000		

Note: The groove on the screw shaft cannot be cut on both ends. Contact THK if you require such a design.

The rigidity values in the table represent spring constants, each obtained from the load and the elastic deformation when providing a preload equal to 10% of the basic axial dynamic load rating (Ca) and applying an axial load three times greater than the preload.

These values do not include the rigidity of the components related to mounting the ball screw nut. Therefore, it is normally appropriate to regard roughly 80% of the value in the table as the actual value.

If the applied preload (Fa<sub>0</sub>) is not 0.1 Ca, the rigidity value (K<sub>N</sub>) is obtained from the following formula.

$$K_N = K \left( \frac{F_{a0}}{0.1Ca} \right)^{\frac{1}{3}}$$

K: Rigidity value in the dimensional table

## Dimensions after Applying Dust-Proofing Seals

### SDA-V

Unit: mm

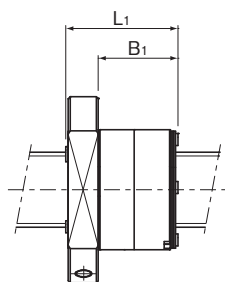

Model No.	SDA-V_CC (with canvas seal)	
	L <sub>1</sub>	B <sub>1</sub>
SDA 1004VZ-4	—	—
SDA 1005VZ-4	—	—
SDA 1010VZ-3	—	—
SDA 1205VZ-3	—	—
SDA 1210VZ-2	—	—
SDA 1220VZ-2	—	—
SDA 1230VZ-2	—	—
SDA 1405V-4	31	21
SDA 1505V-3	26	16
SDA 1510V-3	39	29
SDA 1520V-4	47	37
SDA 1530V-4	65	55
SDA 1605V-3	26	16
SDA 1610V-3	40	30
SDA 1616V-3	56	46
SDA 2004V-4	27	17
SDA 2005V-3	27	17
SDA 2006V-4	36	26
SDA 2010V-3	41	31
SDA 2010V-6	41	31
SDA 2020V-3	68	58
SDA 2020V-6	68	58
SDA 2030V-2	67	57
SDA 2040V-2	85	75
SDA 2060V-2	—	—
SDA 2505V-3	27	17
SDA 2510V-3	41	31
SDA 2520V-3	68	58
SDA 2525V-3	82	72
SDA 2530V-2	66	56
SDA 2530V-4	66	56
SDA 2550V-2	103	93
SDA 2806V-5	43	31
SDA 3110V-5	66	51
SDA 3112V-5	75	60
SDA 3116V-5	94	79

Model No.	SDA-V_CC (with canvas seal)	
	L <sub>1</sub>	B <sub>1</sub>
SDA 3120V-5	113	98
SDA 3132V-2	74	59
SDA 3205V-4	32	20
SDA 3206V-5	43	31
SDA 3208V-5	52	40
SDA 3210V-5	62	50
SDA 3210VA-5	66	51
SDA 3212VA-5	76	61
SDA 3216VA-5	94	79
SDA 3220VA-5	113	98
SDA 3232VA-2	75	60
SDA 3610V-5	66	51
SDA 3612V-5	75	60
SDA 3616V-5	94	79
SDA 3620V-5	113	98
SDA 3636V-2	83	68
SDA 3810V-5	66	51
SDA 3812V-5	75	60
SDA 3815V-5	89	74
SDA 3816V-5	94	79
SDA 3820V-5	113	98
SDA 3825V-4	112	97
SDA 3830V-3	101	86
SDA 3840V-2	89	74
SDA 4008VZ-5	55	41
SDA 4010VA-5	66	51
SDA 4012VA-5	76	61
SDA 4015VA-5	90	74
SDA 4016VA-5	94	79
SDA 4020VA-5	113	98
SDA 4020VA-10	113	98
SDA 4025VA-4	113	98
SDA 4030VA-3	102	87
SDA 4030VA-6	102	87
SDA 4040VA-2	89	74
SDA 4040VA-4	89	74

Model No.	SDA-V_CC (with canvas seal)	
	L <sub>1</sub>	B <sub>1</sub>
SDA 4510V-5	66	49
SDA 4510VA-5	66	49
SDA 4512V-5	75	58
SDA 4512VA-5	76	59
SDA 4516V-5	94	77
SDA 4516VA-5	94	77
SDA 4520V-5	113	96
SDA 4520VA-5	113	96
SDA 4520VA-10	113	96
SDA 4525V-4	112	95
SDA 4525VA-4	112	95
SDA 4530V-4	132	115
SDA 4530VA-4	132	115
SDA 4540V-3	130	113
SDA 4540VA-3	130	113
SDA 5010V-5	66	49
SDA 5010VA-5	66	49
SDA 5012V-5	75	58
SDA 5012VA-5	76	59
SDA 5016V-5	94	77
SDA 5016VA-5	94	77
SDA 5020V-5	113	96
SDA 5020V-10	113	96
SDA 5020VA-5	113	96
SDA 5020VA-10	113	96
SDA 5025V-4	112	95
SDA 5025VA-4	112	95
SDA 5025VA-8	112	95
SDA 5030V-4	131	114
SDA 5030VA-4	132	115
SDA 5030VA-8	132	115
SDA 5040V-3	130	113
SDA 5040VA-3	130	113
SDA 5040VA-6	130	113
SDA 5050V-2	108	91
SDA 5050VA-2	108	91

### SDAN-V

Unit: mm

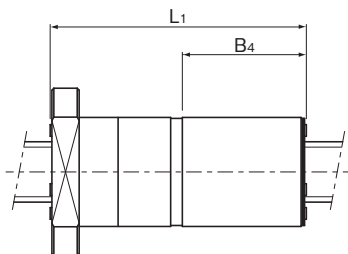

Model No.	SDAN-V_CC (with canvas seal)	
	L <sub>1</sub>	B <sub>4</sub>
SDAN 3110V-5	136	63
SDAN 3112V-5	159	72
SDAN 3116V-5	190	91
SDAN 3120V-5	233	110
SDAN 3205V-4	62	29
SDAN 3206V-5	85	40
SDAN 3208V-5	108	49
SDAN 3210V-5	122	59
SDAN 3210VA-5	136	63
SDAN 3212VA-5	160	72
SDAN 3216VA-5	190	91
SDAN 3220VA-5	233	110
SDAN 3606V-4	73	34
SDAN 3610V-5	136	63
SDAN 3612V-5	159	72
SDAN 3616V-5	190	91
SDAN 3620V-5	233	110
SDAN 3810V-5	136	63
SDAN 3812V-5	159	72
SDAN 3816V-5	190	91
SDAN 3820V-5	233	110
SDAN 4008VX-5	111	52
SDAN 4010VA-5	136	63
SDAN 4012VA-5	160	72
SDAN 4016VA-5	190	91
SDAN 4020VA-5	233	110
SDAN 4510V-5	136	63
SDAN 4510VA-5	136	63
SDAN 4512V-5	159	72
SDAN 4512VA-5	160	72
SDAN 4516V-5	190	91
SDAN 4516VA-5	190	91

Model No.	SDAN-V_CC (with canvas seal)	
	L <sub>1</sub>	B <sub>4</sub>
SDAN 4520V-5	233	110
SDAN 4520VA-5	233	110
SDAN 5010V-5	136	63
SDAN 5010VA-5	136	63
SDAN 5012V-5	159	72
SDAN 5012VA-5	160	72
SDAN 5016V-5	190	91
SDAN 5016VA-5	190	91
SDAN 5020V-5	233	110
SDAN 5020VA-5	233	110
SDAN 5025V-4	237	108
SDAN 5025VA-4	237	108
SDAN 5030V-4	266	128
SDAN 5030VA-4	267	128
SDAN 5040V-3	270	126
SDAN 5040VA-3	270	126
SDAN 5510VX-4	116	53
SDAN 5510VAX-4	116	53
SDAN 5512VX-4	135	60
SDAN 5512VAX-4	135	60
SDAN 5516VX-4	158	75
SDAN 5516VAX-4	158	75
SDAN 5520VX-4	193	90
SDAN 5520VAX-4	193	90
SDAN 6310VX-4	116	53
SDAN 6312VX-4	143	64
SDAN 6316VX-4	165	79
SDAN 6320VX-4	200	94
SDAN 6325VX-4	244	113
SDAN 6330VX-4	273	132
SDAN 6340VX-3	276	130

## Handling

- (1) Please use at least two people to move any product weighing 20 kg or more, or use a cart or another method of conveyance. Otherwise, it may cause injury or damage the unit.
- (2) Do not disassemble the parts. This will result in loss of functionality.
- (3) Tilting the screw shaft and nut may cause them to fall under their own weight.
- (4) Take care not to drop or strike this product. Otherwise, it may cause injury or damage the unit. Even if there is no outward indication of damage, a sudden impact could prevent the unit from functioning properly.
- (5) When assembling, be sure not to remove the nut from the screw shaft.
- (6) Wear appropriate safety gear, such as protective gloves and safety shoes, when handling the product.

## Use

- (1) Prevent foreign materials, such as cutting chips or coolant, from entering the product. Failure to do so could damage the product.
- (2) Prevent foreign materials, such as cutting chips, coolant, corrosive solvents, or water from getting in the product by using a bellows or cover when the product is used in an environment where such a thing is likely.
- (3) Do not use this product if the external temperature exceeds 80°C. If used above this temperature, there is a risk that the resin and rubber parts may deform or become damaged (except for the heat-resistant type).
- (4) If foreign materials such as cutting chips adhere to the product, replenish the lubricant after washing the product.
- (5) Slight oscillations can inhibit the formation of an oil film between the raceways and the area of contact for the balls, resulting in fretting. Therefore, be sure to use a type of grease with high fretting resistance. We recommend periodically rotating the nut once to help ensure that a film forms between the raceways and balls.
- (6) Do not forcibly drive a pin, key, or any other positioning device into the product. This could create indentations in the raceways and impair the product's function.
- (7) Skewing or misalignment of the nut and the element that supports the shaft can drastically reduce service life. Inspect the components carefully and make sure they are mounted correctly.
- (8) If any balls fall out of the nut, contact THK. Do not use the product in that condition.
- (9) If the unit will be mounted vertically, install safety equipment or take other measures to prevent it from falling. The nut may fall under its own weight.
- (10) Do not exceed the permissible rotation speed when using the product. This could damage the product or otherwise cause it to malfunction. Please use the product within the range of speeds we have specified.
- (11) Do not allow the nut to overshoot. The product may malfunction if any of the balls fall out, the circulation components become damaged, or any indentations form in the ball raceways. Continuing to use the product under these circumstances may lead to premature wear or damage to the circulation components.
- (12) Use ball screws in conjunction with guide elements such as an LM Guide or ball spline. Failure to do so could damage the product.
- (13) Insufficient rigidity or accuracy of the mounting surface could cause an unexpected load to act on the ball screw, which could lead to premature failure of the product. Therefore, give sufficient consideration to the rigidity and accuracy of the housing and base.

## Lubrication

- (1) Thoroughly wipe off anti-rust oil and feed lubricant before using the product.
- (2) Do not mix different lubricants. Even grease containing the same type of thickening agent may, if mixed, interact negatively due to disparate additives or other ingredients.
- (3) When using the product in locations exposed to constant vibrations or in special environments such as in clean rooms, vacuums, and extreme heat or cold, use a lubricant suitable for its use/environment.
- (4) When lubricating products that do not feature a grease nipple or lubrication hole, directly coat the raceways with lubricant and perform several warm-up strokes to ensure that the grease permeates the interior.
- (5) Grease viscosity can vary depending on the temperature. Please keep in mind that the torque of the ball screw may be affected by changes in viscosity.
- (6) After lubrication, the rotational torque of the ball screw may increase due to the stirring resistance of the grease. Be sure to perform a warming-up operation and allow the grease to break in sufficiently before operating the machinery.
- (7) Excess grease may spatter after lubrication. Wipe off spattered grease as necessary.
- (8) Grease deteriorates over time, which decreases the lubricity. Perform regular grease inspections and replenish grease based on frequency of use.
- (9) The greasing interval varies depending on the operating conditions and environment. Grease the system approximately every 100 km of travel distance (3 to 6 months). The final greasing interval/amount should be set at the actual machine.
- (10) Depending on the mounting orientation and nut lubrication port position, the lubricant may not circulate sufficiently. Take note of this during the design process.
- (11) It is necessary to provide adequate lubrication when using ball screws. Using the product without lubrication may increase wear on the rolling elements and shorten the service life.

## Storage

When storing the ball screw, pack it as designated by THK and store it indoors in a horizontal position away from high or low temperatures and high humidity. Please note that if the product has been kept in storage for an extended period, the lubricant inside may have deteriorated. Please ensure that you replenish the lubricant before using.

## Disposal

The product should be treated as industrial waste and disposed of appropriately.

## Recommended Products

### High-Speed, Compact Ball Screw Semi-custom **SDA-VZ**

- The nut dimensions comply with ISO, DIN, and JIS standards
- Select stroke length in units of 1 mm.  
The shaft end shape and support unit can be selected.
- Eight products are available with a combination of shaft diameters from  $\phi 15$  to  $\phi 25$  and leads from 5 mm to 20 mm.

Fast-delivery product

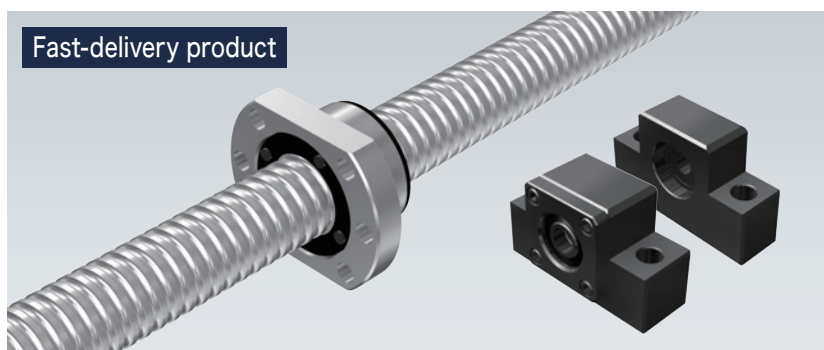

## High-Speed, Compact Caged Ball Screw **SDA-V/SDAN-V**

●“LM Guide” and “” are registered trademarks of THK CO., LTD.

- The actual products may differ from the pictures and photographs in this catalog.
- Outward appearances and specifications are subject to change without notice for the purpose of improvement. Please consult with THK before using.
- Although great care has been taken in the production of this catalog, THK will not take any responsibility for damage resulting from typographical errors or omissions.
- For exports of our products and technologies and sales for export, our basic policy is to comply with the Foreign Exchange and Foreign Trade Act and other laws and regulations. Please consult us in advance if you want to export our products by the piece.

All rights reserved

# THK CO., LTD.

Global Headquarters 2-12-10 Shibaura, Minato-ku, Tokyo 108-8506 Japan

International Sales Department Phone: +81-3-5730-3860

[www.thk.com](http://www.thk.com)