



# Linear Motor Actuators

**GLM10,15,20,25**

High-speed, low dust-generation and  
low noise have been achieved

Dedicated driver  
has been developed



UL Certified products &  
CE Marked products

**THK CO., LTD.**  
TOKYO, JAPAN

CATALOG No.339-4E-CU

# THK Linear Motor Actuators

– Challenging the Boundaries of  
Higher Agility and Accuracy –

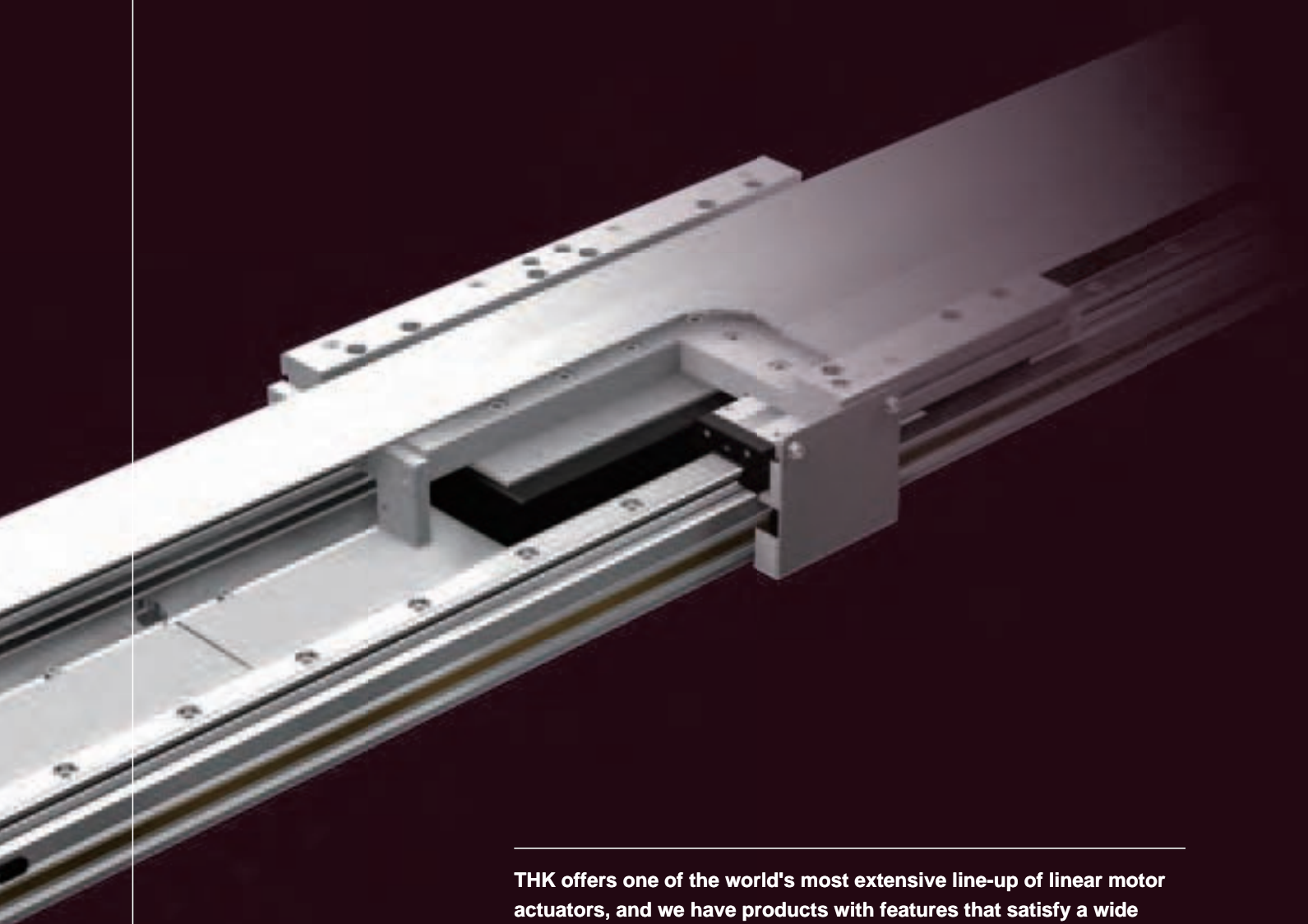

---

**THK offers one of the world's most extensive line-up of linear motor actuators, and we have products with features that satisfy a wide range of applications. THK's actuators are optimized for LM Guide's rated load and motor heat dissipation, enabling the creation of high-quality linear motion systems. Our actuators can be customized in various ways to conform to LM Guides with different surface treatments and lubrication requirements. Special-purpose units can also be created by combining a discrete linear motor with specially designed mechanisms. THK's actuators offer flexible solutions for diverse customer needs.**

---

## Linear Motor Actuator Model GLM

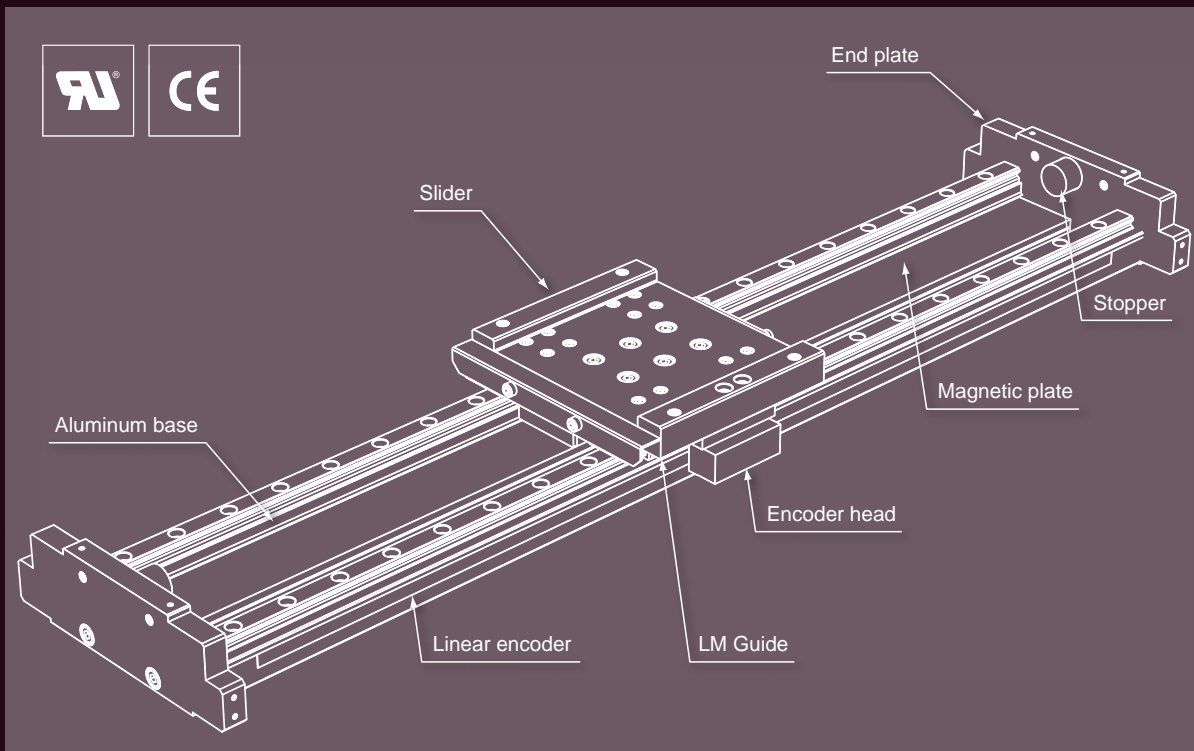

AC linear servo motor with iron core is adopted for Model GLM. Very powerful magnetic field is generated by winding the coil on the iron core, thus it produces high thrust and high acceleration/ deceleration even with small profile.

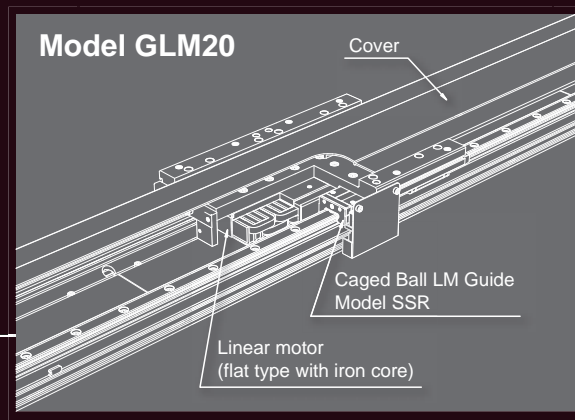

### Structure of Caged Ball LM Guide Model SSR

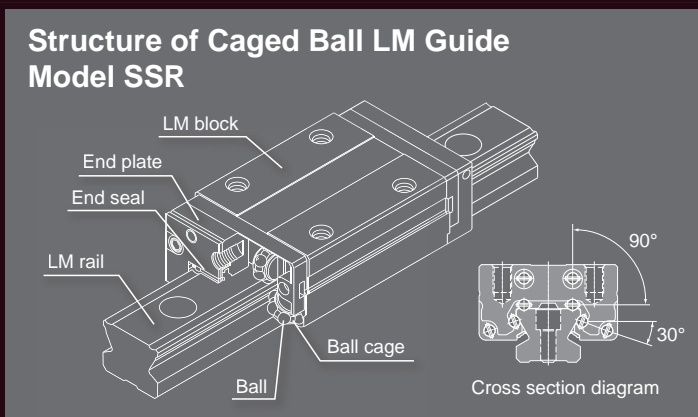

Caged Ball LM Guide Model SSR is an LM Guide that achieves low noise, pleasant sound quality, long maintenance-free operation, long service life and high speed characteristics by adopting a caged ball technology for eliminating the wear caused by friction between balls.

Linear Motor Actuator Model GLM  
**Features**

- 1 High speed**

Linear motor actuator exerts high speed characteristic even with long stroke as it can directly convert electromagnetic force into the linear motion.

Model GLM10 can achieve the maximum speed of 4m/s.  
Even with the other model numbers, the maximum speed of 3m/s is possible.
- 2 High acceleration/ deceleration, superb conformity**

Sharp acceleration and deceleration of 2G are achieved by reducing its weight as a result of using aluminum parts for the slider.

Also, reducing the weight of the slider and high rigidity allow superb conformity.
- 3 High precision**

Outstanding positioning accuracy is achieved by full-closed feedback control\* of the linear encoder.

\* Full-closed feedback control ... This method directly detects the slider position that is operated by the linear encoder.
- 4 Long stroke**

Since the magnetic plates can be jointed, the linear motor actuators can deal with longer strokes that are not possible with ball screw drive actuators.

Also, the joint specifications of the base for GLM15, 20 and 25 enable even longer strokes.
- 5 Multi-sliders**

Multiple sliders can be mounted on a single axis base and controlled independently.
- 6 Clean and quiet operation**

By combining the linear motor with iron core and Caged Ball LM Guide, low noise and low dust-generating operation is achieved.

Note: Model GLM10 uses the full-ball type LM Guide (HSR10RM).

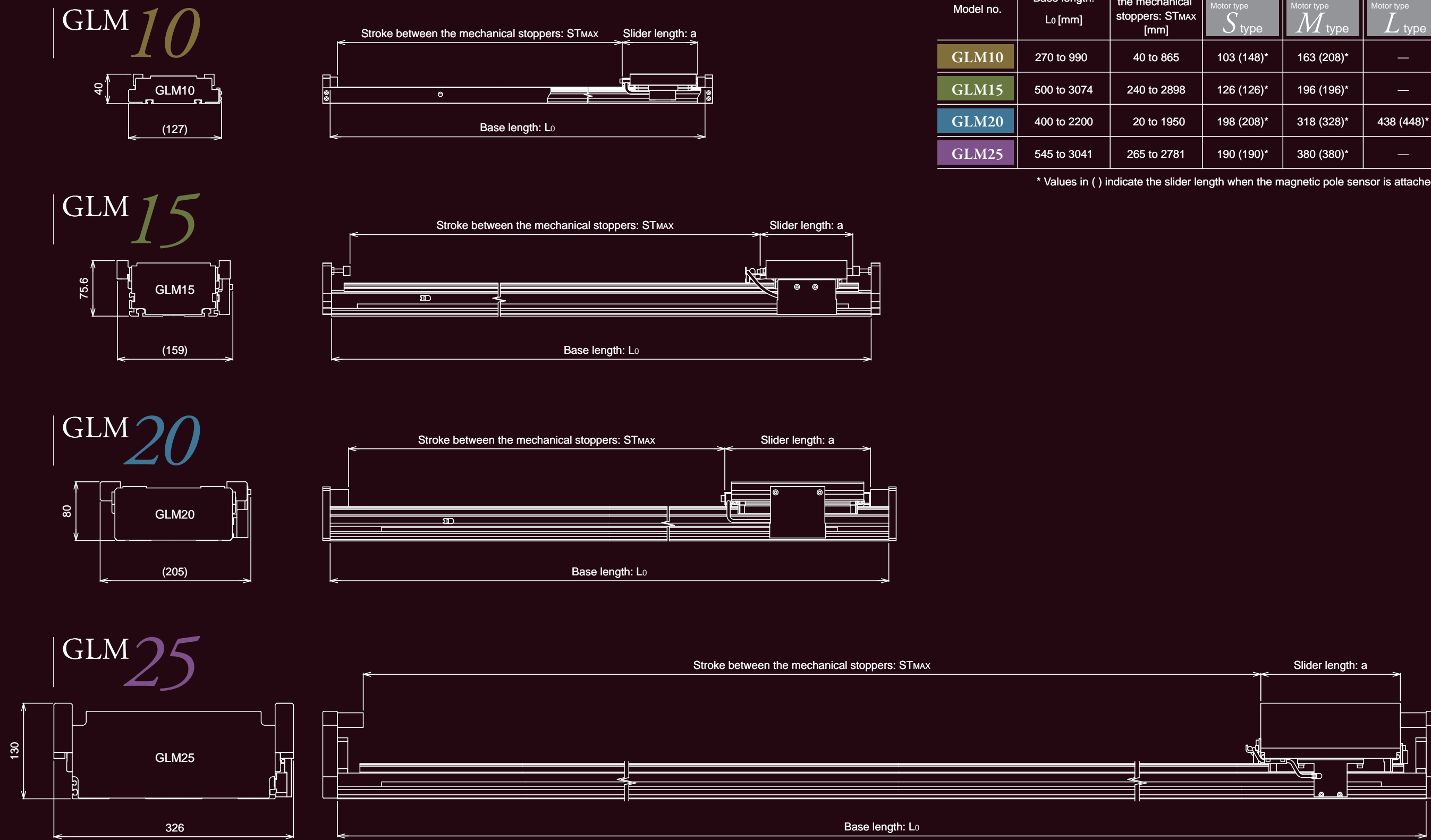

Linear Motor Actuator Model GLM  
**Size Comparison**



Model no.	Base length: L <sub>0</sub> [mm]	Stroke between the mechanical stoppers: ST <sub>MAX</sub> [mm]	Slider length: a [mm]		
			Motor type S type	Motor type M type	Motor type L type
GLM10	270 to 990	40 to 865	103 (148)*	163 (208)*	—
GLM15	500 to 3074	240 to 2898	126 (126)*	196 (196)*	—
GLM20	400 to 2200	20 to 1950	198 (208)*	318 (328)*	438 (448)*
GLM25	545 to 3041	265 to 2781	190 (190)*	380 (380)*	—

\* Values in ( ) indicate the slider length when the magnetic pole sensor is attached.

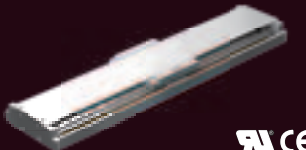
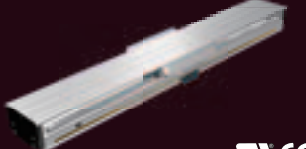
# Performance Comparison

Model no.	Appearance	Features / application example	Motor type (Slider size)	Thrust [N]		Stroke between the mechanical stoppers [mm]		Maximum load capacity [kg]	Positioning repeatability [ $\mu\text{m}$ ]	Resolution [ $\mu\text{m}$ ]	Maximum speed [m/s]		
				Maximum thrust	Rated continuous thrust	Without magnetic pole sensor	With magnetic pole sensor						
GLM10		<ul style="list-style-type: none"> <li>Low-profile design</li> <li>For compact transfer system (up to 53[N])</li> </ul> <b>[Application example]</b> <ul style="list-style-type: none"> <li>Equipment for manufacturing hard disc drive components</li> <li>Semiconductor die bonder</li> </ul>	$S_{\text{type}}$	26	6	145 to 865	100 to 820	6	$\pm 1, \pm 5$ (optical linear encoder)	0.1 to 5.0 (optical linear encoder)	4 (5 $\mu\text{m}$ resolution)		
			$M_{\text{type}}$	53	13	85 to 805	40 to 760	12					
GLM15		<ul style="list-style-type: none"> <li>Extruded aluminum parts with reasonable cost and Caged Ball LM Guide (SSR15XV/XW)</li> <li>For compact transfer system (up to 279[N])</li> </ul> <b>[Application example]</b> <ul style="list-style-type: none"> <li>Semiconductor wafer transfer</li> <li>Transfer of CCD camera for inspection equipment</li> </ul>	$S_{\text{type}}$	150	40	324 to 2898	310 to 2884	19.5	$\pm 1$ (optical linear encoder)	0.1 to 1.0 (optical linear encoder)	3 (1 $\mu\text{m}$ resolution)		
			$M_{\text{type}}$	279	81	254 to 2828	240 to 2814	38.5				$\pm 10$ (magnetic linear encoder)	10.0 (magnetic linear encoder)
GLM20		<ul style="list-style-type: none"> <li>Extruded aluminum parts with reasonable cost and Caged Ball LM Guide (SSR20XW)</li> <li>For medium to large transfer system (up to 933[N])</li> </ul> <b>[Application example]</b> <ul style="list-style-type: none"> <li>Glass substrate transfer system</li> <li>Glass substrate/printed circuit board inspection equipment</li> <li>Glass substrate manufacturing equipment</li> <li>Glass substrate exposure equipment</li> <li>Semiconductor wafer stocker</li> <li>DNA chip manufacturing equipment</li> <li>Large-size inkjet printer</li> <li>Printed circuit board inspection equipment</li> <li>Measuring instrument of automotive parts</li> <li>Plywood manufacturing equipment</li> </ul>	$S_{\text{type}}$	333 (285)*	59 (48)*	150 to 1950	140 to 1940	70	$\pm 1$ (optical linear encoder)	0.1 to 1.0 (optical linear encoder)	3 (1 $\mu\text{m}$ resolution)		
			$M_{\text{type}}$	612 (481)*	113 (124)*	30 to 1830	20 to 1820	140				$\pm 10$ (magnetic linear encoder)	10.0 (magnetic linear encoder)
			$L_{\text{type}}$	933	178	90 to 1710	80 to 1700	210					
GLM25		<ul style="list-style-type: none"> <li>Extruded aluminum parts with reasonable cost and Caged Ball LM Guide (SSR25XW)</li> <li>For ultra-large transfer system (up to 3072[N])</li> </ul> <b>[Application example]</b> <ul style="list-style-type: none"> <li>Large-size glass substrate inspection equipment</li> <li>Large-size glass substrate manufacturing equipment</li> <li>Evaluation equipment of automotive parts</li> </ul>	$S_{\text{type}}$	1557	450	285 to 2781	265 to 2761	193	$\pm 1$ (optical linear encoder)	0.1 to 1.0 (optical linear encoder)	3 (1 $\mu\text{m}$ resolution)		
			$M_{\text{type}}$	3072	892	407 to 2591	402 to 2586	415				$\pm 10$ (magnetic linear encoder)	10.0 (magnetic linear encoder)

\* Values in ( ) are for 100V

## Glossary

### Maximum thrust

This indicates the maximum value of the force that the slider can generate instantaneously towards the traveling direction.

### Rated continuous thrust

This indicates the force that the slider can continuously generate towards the traveling direction.

### Magnetic pole sensor

The sensor that identify N and S poles of the magnet. This is used to detect the positional relationships between the coil of the movable element and N and S poles of the permanent magnet.

### Maximum load capacity

This indicates the maximum weight that can be transferred by loading onto the actuator.  
\* THK defines maximum load capacity as the weight that can be transferred with approx. 0.5G acceleration. For actual selection, see the Selection Method of Model GLM (Pages 62 to 64) in this catalog and please contact THK.

### Optical linear encoder

This is a position detector that detects the positional information of the slider by using light (laser light). This is used for the application that require high precision and high resolution.

### Magnetic linear encoder

This is a position detector that detects the positional information of the slider by using magnetism. This possesses superb weatherability compared to the optical type. Also, the magnetic linear encoder is normally used when the overall length of the unit is the joint specification.

### Positioning repeatability (diagram on the right)

Position to a given point from the same direction seven times, measure the stopping points and then calculate the value of half the maximum difference of the reading. Perform this measurement at the center and at both ends of the travel distance; the largest value becomes the measurement value, and the positioning repeatability is expressed by placing the symbol " $\pm$ " next to the value of half the maximum difference.

### Resolution

Minimum travel distance that can be set. Note: This does not guarantee the positioning accuracy.

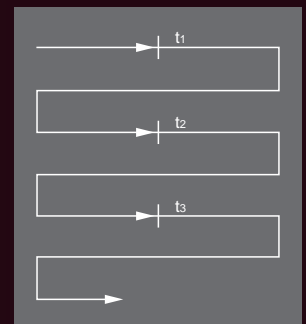

Positioning repeatability

# TD Driver: Designed Especially for Driving Linear Motors

Model no.	Main circuit power supply voltage	External dimensions/ weight	Power capacity [kVA]	Appearance	Compatible linear motor actuator(s)
TD-010CU-100AC TD-010CU-200AC TD-020CU-200AC TD-045CU-100AC TD-045CU-200AC	AC200V Single-phase/ three-phase  AC100V Single-phase	W: 60mm H: 180mm L: 125mm  Weight: 1.0kg	0.2 to 1.4	 	GLM10S/10M  GLM15S/15M  GLM20S 
TD-075CU-100AC TD-075CU-200AC	AC200V Single-phase/ three-phase  AC100V Single-phase	W: 65mm H: 180mm L: 162mm  Weight: 1.3kg	0.9 to 1.9	 	GLM20M 
TD-100CU-200AC	AC200V Three-phase	W: 94.5mm H: 180mm L: 165mm  Weight: 2.0kg	2.3	 	GLM20L 
TD-150CU-200AC	AC200V Three-phase	W: 101.5mm H: 180mm L: 165mm  Weight: 2.1kg	3.2	 	GLM25S 
TD-300CU-200AC		W: 239mm H: 180mm L: 165mm  Weight: 3.9kg			

## Features

- Driver designed especially for driving linear motors**

The drivers are specifically designed for driving linear motors in order to maximize the features of the linear motor actuators such as high speed, sharp acceleration/deceleration and outstanding constant speed.
- Superior servo performance**

Outstanding servo performance is achieved as a result of adopting THK's unique control algorithm.
- Compact design**

Compactness is achieved by reducing the number of parts.
- Conforming to international authoritative standards that have reputation of superb safety and reliability**

All the electronic parts/printed circuit boards and sheet metal/painting conform to RoHS directive (→ P.9). Also, this is fully compliant with THK green procurement (→ P.9). Reliability is improved as a result of obtaining CE Marking.
- Adequate setup tools**

Parameter and others can be set easily by digital operator [D-Con] and PC communications software [D-ASYS].

## TD Driver: Designed Especially for Driving Linear Motors

# Setup Tools

### Digital operator D-Con

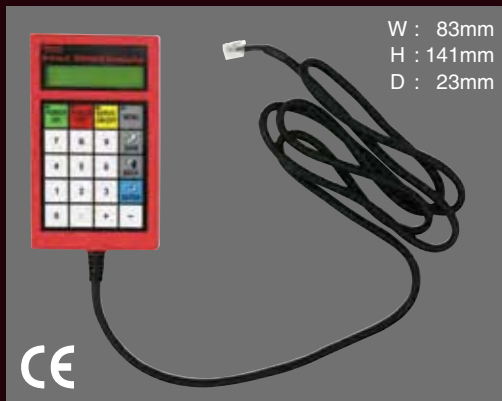

#### Features

##### Quick setup

Quick setup is possible by simply connecting it to the TD driver.

##### Easy operation

Sheet key and highly visible LCD display (16 characters x 2 lines). Even beginners can easily set the parameters.

#### Function

- Parameter checking/change/writing/saving
- Monitor (I/O, position, alarm, actual load factor)
- JOG/INDEX operation
- Communication speed setting

### PC communications software D-ASYS



#### Features

##### Easy to operate on PC

Other than D-Con, the operational state can be observed with waveform display using your own PC.

##### Communications software is offered free of charge from the website

Communications software can be downloaded free of charge after logging in the THK technical support site. (Japanese and English are available) <https://tech.thk.com/>

#### Function

- Parameter checking/change/writing/saving
- Monitor (I/O, position, alarm, actual load factor)
- Logging (position/speed/waveform display of current)
- JOG/INDEX operation
- Communication speed setting

### Glossary

#### UL Approval

UL stands for Underwriters Laboratories Inc., a nonprofit organization in the United States. The UL standard created by UL has garnered the public trust as the highest authority for safety standards, and the UL Marking is used by many state and local governments in the US. In addition, products with UL approval are widely recognized among consumers to have their "safety and reliability verified by a third party".

##### UL1004 (motor)

- Standard for the overall motor structure: Electrical safety (heat generation, fire)

##### UL508C (driver)

- Standard for power converters: Electrical safety (heat generation, fire)

THK's UL approval registration  
File no.

Linear motor: E315198  
Driver: E315162

\* For more details on UL, visit the Underwriters Laboratories website.  
<http://www.ul.com/>

#### RoHS directive

This is a hazardous substances control act enforced by EU on July 1, 2006, prohibiting electric and electronic equipment to contain the specified hazardous substances. If the products contain the hazardous substances that are controlled by this directive, they cannot be sold within the EU region.



#### CE Marking



Statutory safety logo for the products sold in the EU region. For the unit products such as drivers, etc., obtaining the CE Marking approval became fully compulsory from January 1996 by the EMC directive and low voltage directive.

##### ① EMC directive

- Immunity test: Capacity to withstand noise from outside
- Emission test: Capacity to reduce the release of noise to outside

##### ② Low voltage directive

- Requirement of electric safety for the electric products that are operated by the power source of 50 to 1000VAC and 75 to 1500VDC.

#### THK green procurement

THK Group, through the development of its business activities as well as the social life of each employee, acknowledges that we are deeply related to global environment, and thus would like to tackle with effectively reducing environmental impact. When procuring raw materials and parts used in the production of the products, or those indirect materials and tools used in the production processes, THK Group implements the measures to consider reducing their impact on the environment.

# Table of Contents

## GLM 10



- ▶ Product Specifications ..... P.11
- ▶ Model Number Chart ..... P.12 to 14
- ▶ System Configuration ..... P.14
- ▶ Dimensions ..... P.15
- ▶ Sensor, T-Slot,  
Cable Carrier Dimensions ..... P.16
- ▶ Cable Specifications ..... P.59 to 61
- ▶ Selection Method ..... P.62 to 64

## GLM 15



- ▶ Product Specifications ..... P.17, 18
- ▶ Model Number Chart ..... P.19 to 22
- ▶ System Configuration ..... P.23, 24
- ▶ Dimensions ..... P.25, 26
- ▶ Sensor, T-Slot,  
Cable Carrier Dimensions ..... P.27, 28
- ▶ External Dimensions of the Interpolator  
Cable Specifications, Nuts for Mounting the Base .. P.59 to 61
- ▶ Selection Method ..... P.62 to 64

## GLM 20



- ▶ Product Specifications ..... P.29, 30
- ▶ Model Number Chart ..... P.31 to 34
- ▶ System Configuration ..... P.35, 36
- ▶ Dimensions ..... P.37 to 39
- ▶ Sensor, T-Slot,  
Cable Carrier Dimensions ..... P.40, 41
- ▶ External Dimensions of the Interpolator  
Cable Specifications, Nuts for Mounting the Base .. P.59 to 61
- ▶ Selection Method ..... P.62 to 64

## GLM 25



- ▶ Product Specifications ..... P.43, 44
- ▶ Model Number Chart ..... P.45 to 48
- ▶ System Configuration ..... P.49, 50
- ▶ Dimensions ..... P.51 to 54
- ▶ Sensor, Cable Carrier Dimensions ..... P.55
- ▶ External Dimensions of the Interpolator  
Cable Specifications ..... P.59 to 61
- ▶ Selection Method ..... P.62 to 64

## Driver Model TD



- ▶ Driver Specifications ..... P.56
- ▶ External Dimensions of the Driver ..... P.57, 58

GLM10

GLM15

GLM20

GLM25

Driver Model TD

# Product Specifications

## Specifications

Item	Motor type		S type								M type							
			TD-010CU-200AC				TD-010CU-100AC				TD-010CU-200AC				TD-010CU-100AC			
Applicable driver			TD-010CU-200AC				TD-010CU-100AC				TD-010CU-200AC				TD-010CU-100AC			
Main circuit power supply voltage			200VAC single-phase/three-phase				100VAC single-phase				200VAC single-phase/three-phase				100VAC single-phase			
Maximum thrust [N] <sup>*1</sup>			26								53							
Rated continuous thrust [N] <sup>*1</sup>			6								13							
Maximum speed [m/s] <sup>*2</sup>	4.0	3.0	1.5	0.3	2.0	2.0	1.5	0.3	4.0	3.0	1.5	0.3	2.0	2.0	1.5	0.3		
Resolution [μm]	5.0	1.0	0.5	0.1	5.0	1.0	0.5	0.1	5.0	1.0	0.5	0.1	5.0	1.0	0.5	0.1		
Positioning repeatability [μm]	±5		±1				±5				±1				±5			
Maximum load capacity [kg] <sup>*3</sup>			6								12							
Estimated mass [kg] <sup>*4</sup>			0.5								1.2							

\*1 This is the value in which the motor is driven with 100% of root-mean-square thrust under the condition with the ambient temperature of 20°C.

\*2 Maximum speed varies according to the linear scale resolution.

E.g.: Motor type - S type, selected driver - TD-010CU-200AC, resolution - 1.0μm, maximum speed - 3.0m/s

\*3 Speed and/or acceleration/deceleration may be restricted by the payload mass. See "Selection Method of Model GLM" on Pages 62 to 64.

\*4 Mass that can be driven with the acceleration of approx. 2G. However, operable weight may vary as it may be affected by thrust and speed characteristics depending on speed.

## Thrust - speed characteristics

### [200V main circuit power supply]

Motor type : S type  
Driver model no.: TD-010CU-200AC

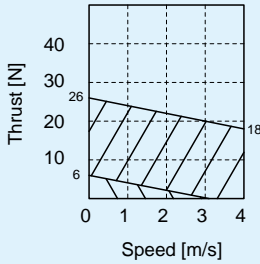

Motor type : M type  
Driver model no.: TD-010CU-200AC

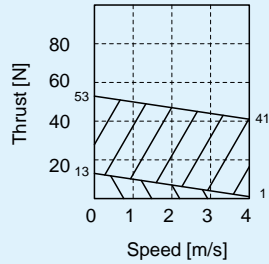

▨ Maximum thrust    ▨ Rated continuous thrust

### [100V main circuit power supply]

Motor type : S type  
Driver model no.: TD-010CU-100AC

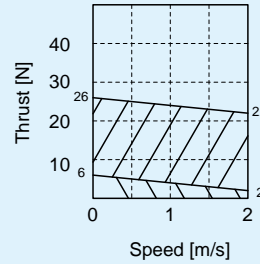

Motor type : M type  
Driver model no.: TD-010CU-100AC

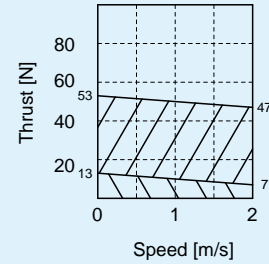

▨ Maximum thrust    ▨ Rated continuous thrust

## Base specifications

Item			Stroke between the mechanical stoppers: ST <sub>MAX</sub> [mm]			
Base length: L <sub>0</sub> [mm]	Base model no.	Base section mass [kg]	Motor type: S type		Motor type: M type	
			Without magnetic pole sensor	With magnetic pole sensor	Without magnetic pole sensor	With magnetic pole sensor
270	027	1.4	145	100 <sup>*1</sup>	85 <sup>*1</sup>	40 <sup>*1</sup>
510	051	2.6	385	340	325	280
750	075	3.6	625	580	565	520
990	099	4.8	865	820	805	760

\*1 When combined between short base length and long slider, some may not be able to use the base mounting hole in the central section.  
In this case, consider fixing the base with the T-slots.

Note 1: Maximum length of the single base is 1960mm.

Note 2: The stroke between the mechanical stoppers listed in the table above is for one slider.

Note 3: The standard length bases are recommended to conform to the standard magnet plate length.

# Model Number Chart

## Main unit

**2 GLM10 - 099 - S - EP - C - NN - D - B - N - N - D04 - E01 - CU**

①      ②                  ③      ④      ⑤      ⑥      ⑦      ⑧      ⑨      ⑩      ⑪                  ⑫                  ⑬                  ⑭

① Combined no. of sliders	* Omitted when the number is 1.						
② Model no.	GLM10						
③ Base model no.	* See "Model GLM10 Base specifications" (→P.11).						
④ Motor type (Slider size)	S : S type M : M type * See "Model GLM10 Specifications" (→P.11).						
⑤ End plate	EP : With standard end plate (both ends)						
⑥ Cover	C : With aluminum plate cover N : No cover						
⑦ Resolution	* See "Model GLM10 Specifications" (→P.11). Following types can be selected according to resolution. <table style="display: inline-table; vertical-align: middle;"> <tr> <td>NR : Resolution 5.0μm</td> <td rowspan="4" style="font-size: 3em; vertical-align: middle;">}</td> <td rowspan="4" style="vertical-align: middle;">With the optical linear encoder (RENISHAW)</td> </tr> <tr> <td>NN : Resolution 1.0μm</td> </tr> <tr> <td>NU : Resolution 0.5μm</td> </tr> <tr> <td>NV : Resolution 0.1μm</td> </tr> </table> * The values of resolution are after quadrature.	NR : Resolution 5.0μm	}	With the optical linear encoder (RENISHAW)	NN : Resolution 1.0μm	NU : Resolution 0.5μm	NV : Resolution 0.1μm
NR : Resolution 5.0μm	}	With the optical linear encoder (RENISHAW)					
NN : Resolution 1.0μm							
NU : Resolution 0.5μm							
NV : Resolution 0.1μm							
⑧ Sensor	K : Proximity sensor GL-12F [N.O. contact] (3pcs.) (SUNX) D : Proximity sensor GXL-N12F [N.O. contact] (1pc.) (SUNX) GXL-N12FB [N.C. contact] (2pcs.) N : No sensor						
⑨ Cable carrier	B : TKP0180W40R37 (Tsubakimoto Chain Co.) N : No cable carrier <b>Note:</b> Main unit must come with a cable carrier in order for it to conform to UL Certifications and CE Marking. (Items conforming to CE Marking requirements have a protective cover on the cable connector) Also, please note that the main unit without the cable carrier only conforms to UL Certification. (If selecting the main unit without the cable carrier, the conforming product/certified product code ⑭ will be "UL".) * Cable carriers other than the standard equipment can also be selected. For more information, please contact THK.						
⑩ Magnetic pole sensor	J : With magnetic pole sensor equipped N : No magnetic pole sensor * In case that the magnetic pole sensor is not equipped, when the power is turned on, automatic magnetic pole detection is executed when the first Servo-On command is sent. During the automatic magnetic pole detection, the slider will travel several millimeters back and forth for approximately 10 seconds. The item with the magnetic pole sensor must be selected in order to avoid this motion.						
⑪ Design no.	N * If several sliders are combined on single axis base, the standard setting will be restricted. For more information, please contact THK.						
⑫ Power cable	D00 : No power cable required D04 : Cable length 4m D06 : Cable length 6m D08 : Cable length 8m <b>Note:</b> For the combinations of the power cable and encoder/magnetic pole sensor cables, see Page 14.						

[The model number chart for the main unit continues on the next page]

## Main unit

<p>⑬ Encoder cable</p>	<p>E00 : Encoder cable not required            E01 : Cable length 1m            E03 : Cable length 3m            E05 : Cable length 5m</p> <p>* When the magnetic pole sensor code ⑩ is specified as N            ⇒ KET cable (specified length) is included.</p> <p>* When the magnetic pole sensor code ⑩ is specified as J            ⇒ KGET cable (specified length) is included.</p> <p>Note: For the combinations of the power cable and encoder/magnetic pole sensor cables, see Page 14.</p>
<p>⑭ Conforming product/ certified product code</p>	<p>CU : UL Certified products &amp; CE Marked products            UL : UL Certified products only (without cable carrier)</p> <p>Note: Main unit must come with a cable carrier in order for it to conform to UL Certifications and CE Marking. (Items conforming to CE Marking requirements have a protective cover on the cable connector) Also, please note that the main unit without the cable carrier only conforms to UL Certification.</p>

## Driver

# TD - 010CU - 200AC - G10MU - 1U - N

①	②	③	④	⑤	⑥
① Model no.	TD : Driver model code				
② Capacity	010CU : 100W (for both S type and M type motors)				
③ Input power	100AC : Single-phase 100VAC 200AC : Single-phase/three-phase 200VAC				
④ Motor type	G10SU : GLM10 S type G10MU : GLM10 M type				
⑤ Resolution (value + unit)	5U : 5.0μm 1U : 1.0μm 500N : 0.5μm 100N : 0.1μm				
⑥ Magnetic pole sensor	J : With magnetic pole sensor equipped N : No magnetic pole sensor				

## Cable

\* The model GLM10 comes with a power cable, the encoder cable, and the magnetic pole sensor cable.  
When purchasing a separate cable for maintenance, specify the following model number.

# K DST - 04 - CU

①	②	③
① Model no.	K : Cable model code	
② Type	DST : Power cable (standard length of the cable: 4m, 6m, 8m) ET : Encoder cable (standard length of the cable: 1m, 3m, 5m) GET : Encoder/magnetic pole sensor cable (standard length of the cable: 1m, 3m, 5m)	
③ Cable length [Unit: m]	04 : 4m (please select from standard length) * If the cable other than the standard length is required, please contact THK.	



## Dimensions S type

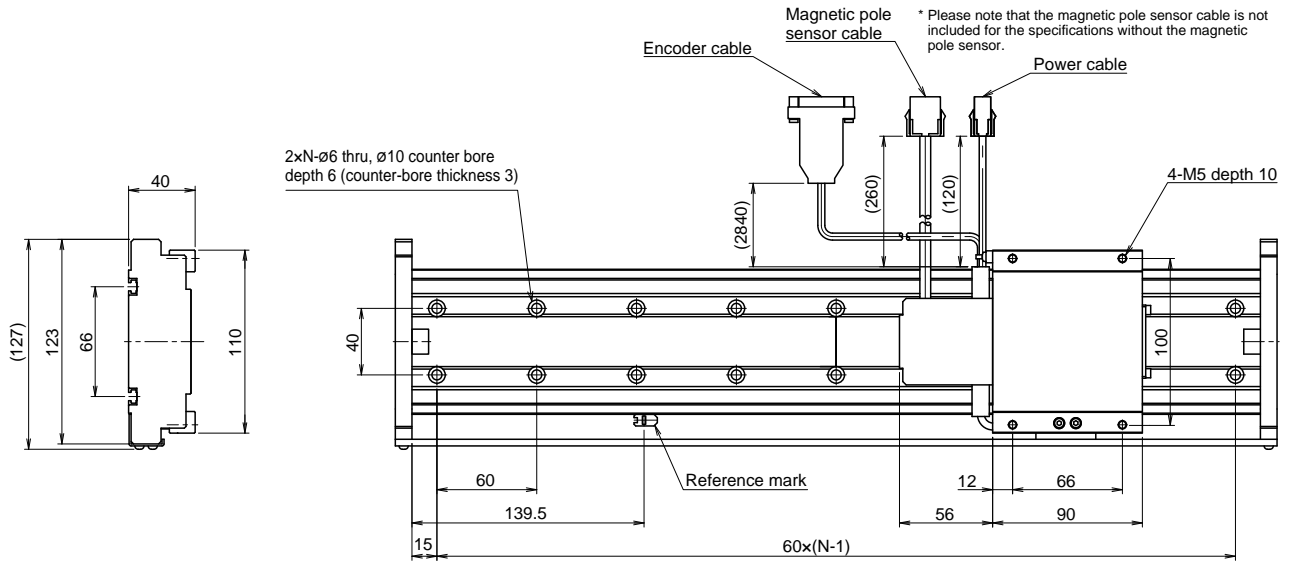

Base length: $L_0$ [mm]	No. of mounting holes per row N
270	5
510	9
750	13
990	17

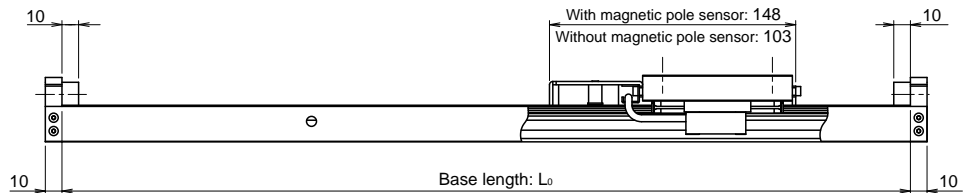

Note: The above diagram is for the specifications with the magnetic pole sensor. Slider length will differ for the specifications without the magnetic pole sensor. Also, please note that the magnetic pole sensor cable is not included.

## Dimensions M type

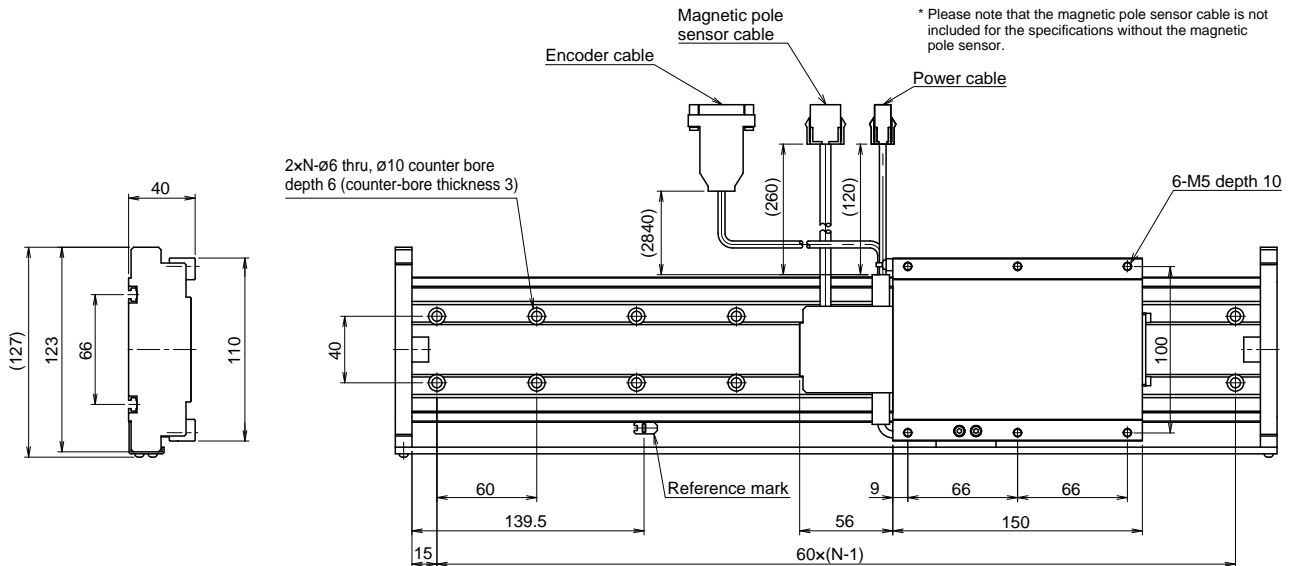

Base length: $L_0$ [mm]	No. of mounting holes per row N
270	5
510	9
750	13
990	17

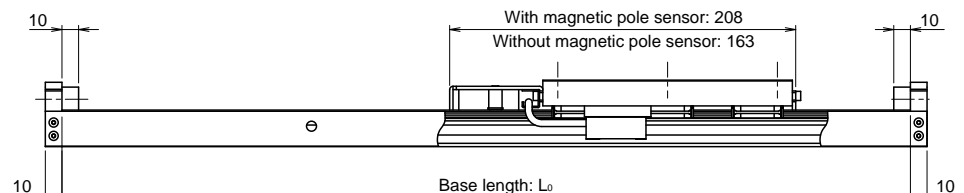

Note: The above diagram is for the specifications with the magnetic pole sensor. Slider length will differ for the specifications without the magnetic pole sensor. Also, please note that the magnetic pole sensor cable is not included.

# Sensor/T-Slot/Cable Carrier Dimensions

## Proximity sensor

GL-12F [N.O. contact] (3pcs.) (SUNX)

GXL-N12F [N.O. contact] (1pc.) (SUNX)

GXL-N12FB [N.C. contact] (2pcs.)

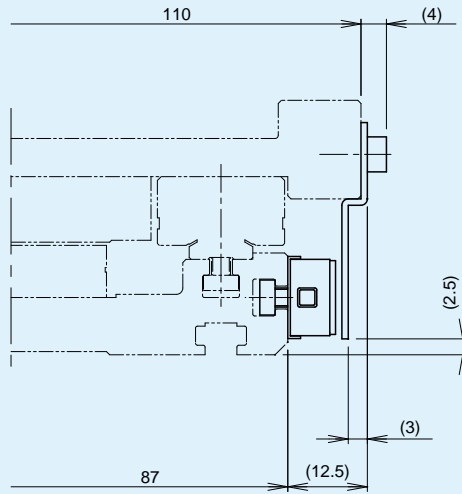

## T-slot

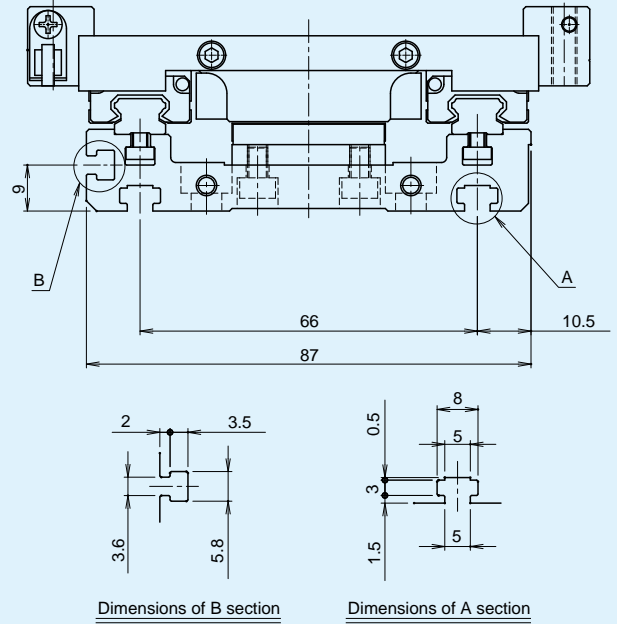

## Standard cable carrier B

TKP0180W40R37 (Tsubakimoto Chain Co.)

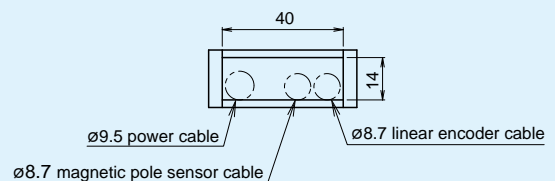
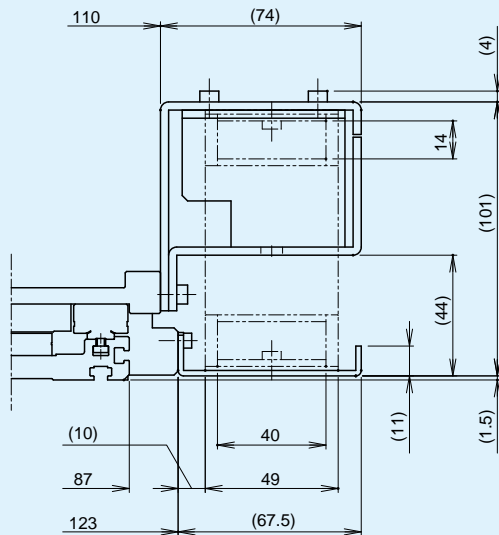

Cross section of the cable carrier

GLM10

GLM15

GLM20

GLM25

Driver Model TD

# Product Specifications

## Specifications

Item	Motor type	S type								M type							
Applicable driver		TD-010CU-200AC				TD-010CU-100AC				TD-020CU-200AC				TD-020CU-100AC			
Main circuit power supply voltage		200VAC single-phase/three-phase				100VAC single-phase				200VAC single-phase/three-phase				100VAC single-phase			
Maximum thrust [N]*1		150								279							
Rated continuous thrust [N]*1		40								81							
Maximum speed [m/s]*2		3.0	3.0	1.5	0.3	1.7	1.7	1.5	0.3	3.0	3.0	1.5	0.3	1.7	1.7	1.5	0.3
Resolution [ $\mu\text{m}$ ]		10.0	1.0	0.5	0.1	10.0	1.0	0.5	0.1	10.0	1.0	0.5	0.1	10.0	1.0	0.5	0.1
Positioning repeatability [ $\mu\text{m}$ ]		$\pm 10$	$\pm 1$			$\pm 10$	$\pm 1$			$\pm 10$	$\pm 1$			$\pm 10$	$\pm 1$		
Maximum load capacity [kg]*3		19.5								38.5							
Estimated mass [kg]*4		2.6								6.3							

\*1 This is the value in which the motor is driven with 100% of root-mean-square thrust under the condition with the ambient temperature of 20°C.

\*2 Maximum speed varies according to the linear scale resolution.

E.g.: Motor type - S type, selected driver - TD-010CU-200AC, resolution - 1.0 $\mu\text{m}$ , maximum speed - 3.0m/s

\*3 Speed and/or acceleration/deceleration may be restricted by the payload mass. See "Selection Method of Model GLM" on Pages 62 to 64.

\*4 Mass that can be driven with the acceleration of approx. 2G. However, operable weight may vary as it may be affected by thrust and speed characteristics depending on speed.

## Thrust - speed characteristics

### [200V main circuit power supply]

Motor type : S type  
Driver model no. : TD-010CU-200AC

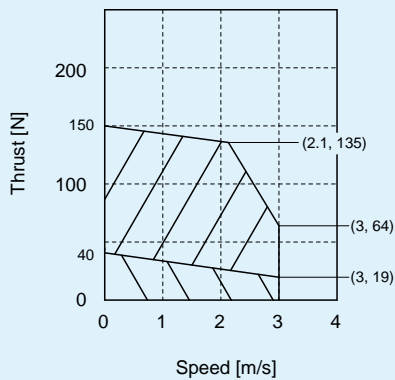

Motor type : M type  
Driver model no. : TD-020CU-200AC

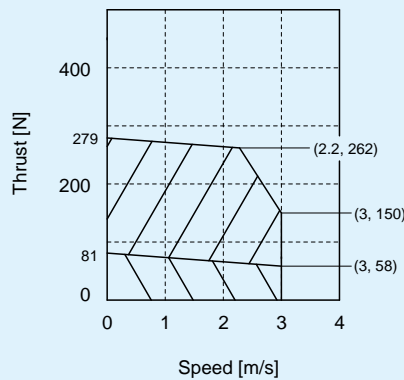

### [100V main circuit power supply]

Motor type : S type  
Driver model no. : TD-010CU-100AC

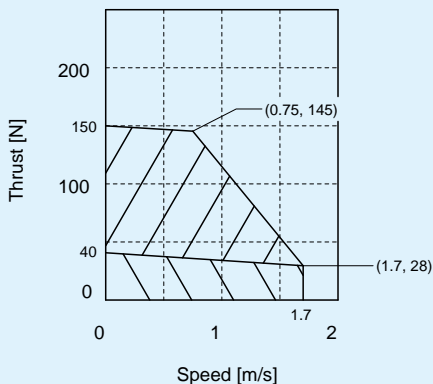

Motor type : M type  
Driver model no. : TD-020CU-100AC

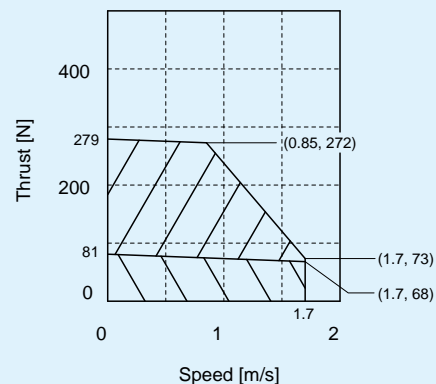

Maximum thrust  
 Rated continuous thrust

## Base specifications

Item			Stroke between the mechanical stoppers: ST <sub>MAX</sub> [mm]			
Base length: L <sub>0</sub> [mm]	Base model no.	Base section mass [kg]	Motor type: S type		Motor type: M type	
			Without magnetic pole sensor	With magnetic pole sensor	Without magnetic pole sensor	With magnetic pole sensor
500	050	4.6	324	310	254	240
734	073	6.9	558	544	488	474
968	096	9.0	792	778	722	708
1202	120	11.3	1026	1012	956	942
1436	143	13.6	1260	1246	1190	1176
1670	167	15.9	1494	1480	1424	1410
1904	190	18.2	1728	1714	1658	1644
2138	213	21.2	1962	1948	1892	1878
2372	237	23.5	2196	2182	2126	2112
2606	260	25.9	2430	2416	2360	2346
2840	284	28.2	2664	2650	2594	2580
3074	307	30.6	2898	2884	2828	2814

Note 1: The stroke between the mechanical stoppers listed in the table above is for one slider.

Note 2: The standard length bases are recommended to conform to the standard magnet plate length.

Note 3: Maximum length of the single base is 3776mm.

GLM10

GLM15

GLM20

GLM25

Driver Model TD



## Main unit

⑫ Power cable	D00 : No power cable required
	D01 : Cable length 1m D03 : Cable length 3m D05 : Cable length 5m D10 : Cable length 10m D15 : Cable length 15m
Note: For the combinations of the power cable and encoder/magnetic pole sensor cables, see Pages 23 and 24.	
⑬ Encoder cable	E00 : Encoder cable not required
	E01 : Cable length 1m E03 : Cable length 3m E05 : Cable length 5m E10 : Cable length 10m E15 : Cable length 15m
* When the resolution ⑦ is specified as NN, NU, or NV and the magnetic pole sensor code ⑩ is specified as N ⇒ KET cable (specified length) is included.	
* When the resolution ⑦ is specified as NN, NU, or NV and the magnetic pole sensor code ⑩ is specified as J ⇒ KJET cable (specified length) is included.	
* When the resolution ⑦ is specified as TD and the magnetic pole sensor code ⑩ is specified as N ⇒ KSET cable (1m) and CK cable (specified length) are included. CE09 cable is not included.	
* When the resolution ⑦ is specified as TD and the magnetic pole sensor code ⑩ is specified as J ⇒ KSJT cable (interpolator side - 1m/magnetic pole sensor side - specified length) and CK cable (specified length) are included. CE09 cable is not included.	
Note: For the combinations of the power cable and encoder/magnetic pole sensor cables, see Pages 23 and 24.	
⑭ Conforming product/ certified product code	CU : UL Certified products & CE Marked products
	UL : UL Certified products only (without cable carrier)
Note: Main unit must come with a cable carrier in order for it to conform to UL Certifications and CE Marking. (Items conforming to CE Marking requirements have a protective cover on the cable connector) Also, please note that the main unit without the cable carrier only conforms to UL Certification.	

## Driver

# TD - 010CU - 200AC - G15SU - 1U - N

①	②	③	④	⑤	⑥
① Model no.	TD	: Driver model code			
② Capacity	010CU	: 100W (for S type motor)			
	020CU	: 200W (for M type motor)			
③ Input power	100AC	: Single-phase 100VAC			
	200AC	: Single-phase/three-phase 200VAC			
④ Motor type	G15SU	: GLM15 S type			
	G15MU	: GLM15 M type			
⑤ Resolution (value + unit)	10U	: 10.0μm			
	1U	: 1.0μm			
	500N	: 0.5μm			
	100N	: 0.1μm			
⑥ Magnetic pole sensor	J	: With magnetic pole sensor equipped			
	N	: No magnetic pole sensor			



## D - CON2

①

②

① Model no.

D : Setup support tool

② Type

CON2 : Digital operator

ASYS : PC communications software

\* D-ASYS (PC communications software) can be downloaded from THK's technical support site after logging in. Technical support site: <https://tech.thk.com/>

- Communication cable (cable for connecting to PC when using D-ASYS)

## K232 - 01

①

① Cable length

01 : 1m

## System configuration: With the optical linear encoder (RENISHAW)

Specifications without the magnetic pole sensor

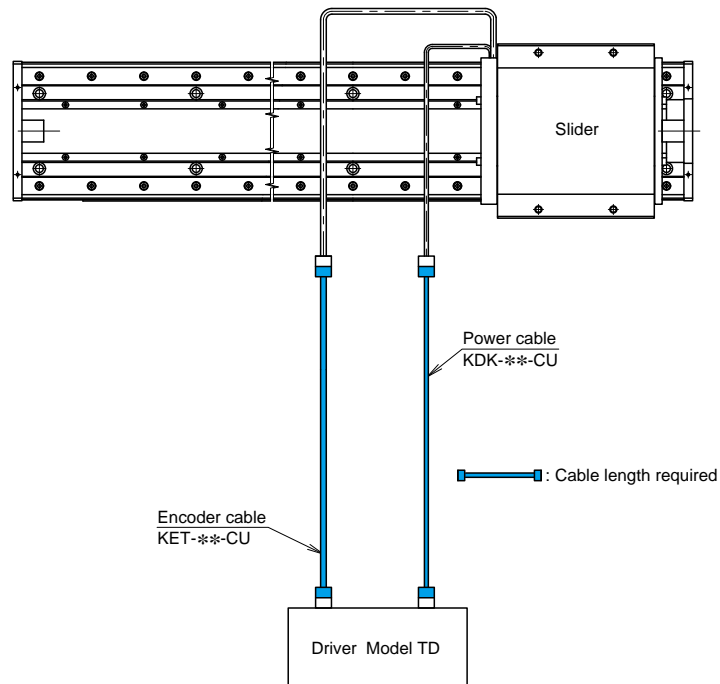

\* Customer is to provide the controller.

Specifications with the magnetic pole sensor

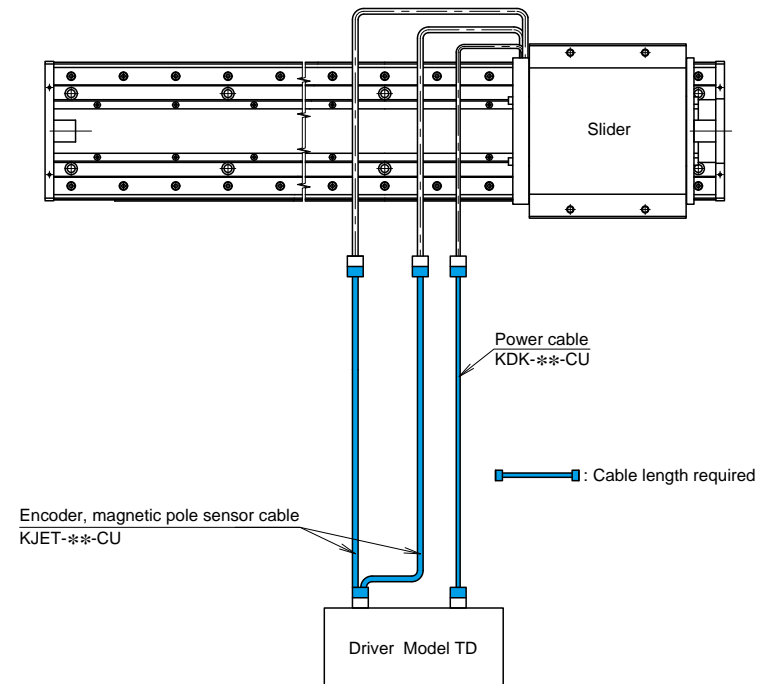

\* Customer is to provide the controller.

## ■ Combinations of the power cable and encoder/magnetic pole sensor cables

Cable length required	Power cable model no. [model no. of the main unit]	Specifications without the magnetic pole sensor	Specifications with the magnetic pole sensor
		Encoder cable model no. [model no. of the main unit]	Encoder/magnetic pole sensor cable model no. [model no. of the main unit]
1m	KDK-01-CU [D01]	KET-01-CU [E01]	KJET-01-CU [E01]
3m	KDK-03-CU [D03]	KET-03-CU [E03]	KJET-03-CU [E03]
5m	KDK-05-CU [D05]	KET-05-CU [E05]	KJET-05-CU [E05]
10m	KDK-10-CU [D10]	KET-10-CU [E10]	KJET-10-CU [E10]
15m	KDK-15-CU [D15]	KET-15-CU [E15]	KJET-15-CU [E15]

Note: The table above is a standard combination of the cable length. If the combinations other than the table above is required, please contact THK.

## System configuration: With the magnetic linear encoder (Sony Manufacturing Systems)

### Specifications without the magnetic pole sensor

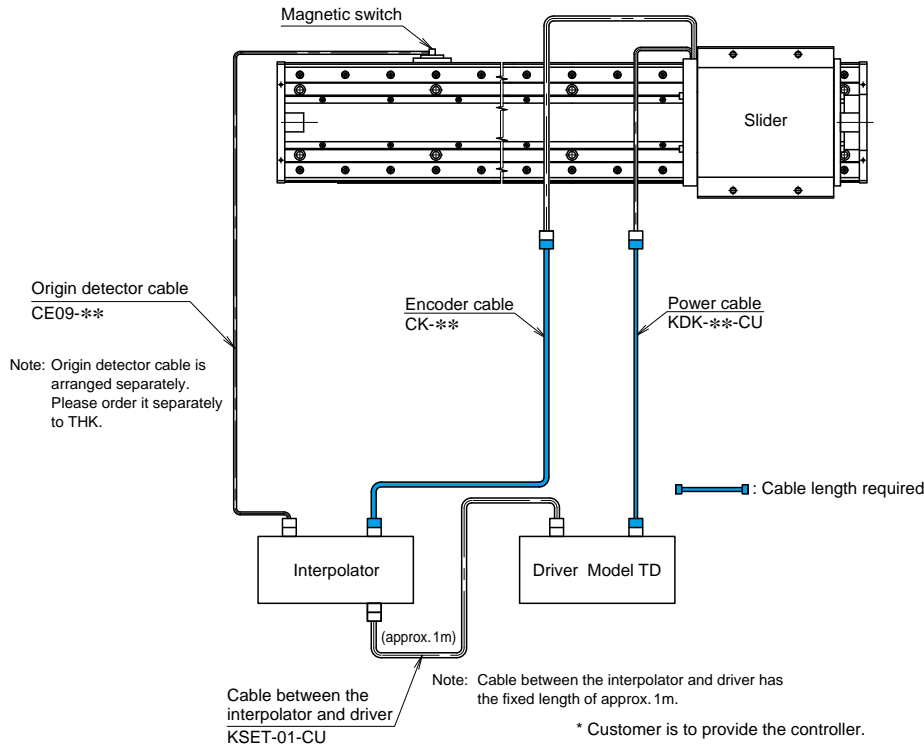

### Specifications with the magnetic pole sensor

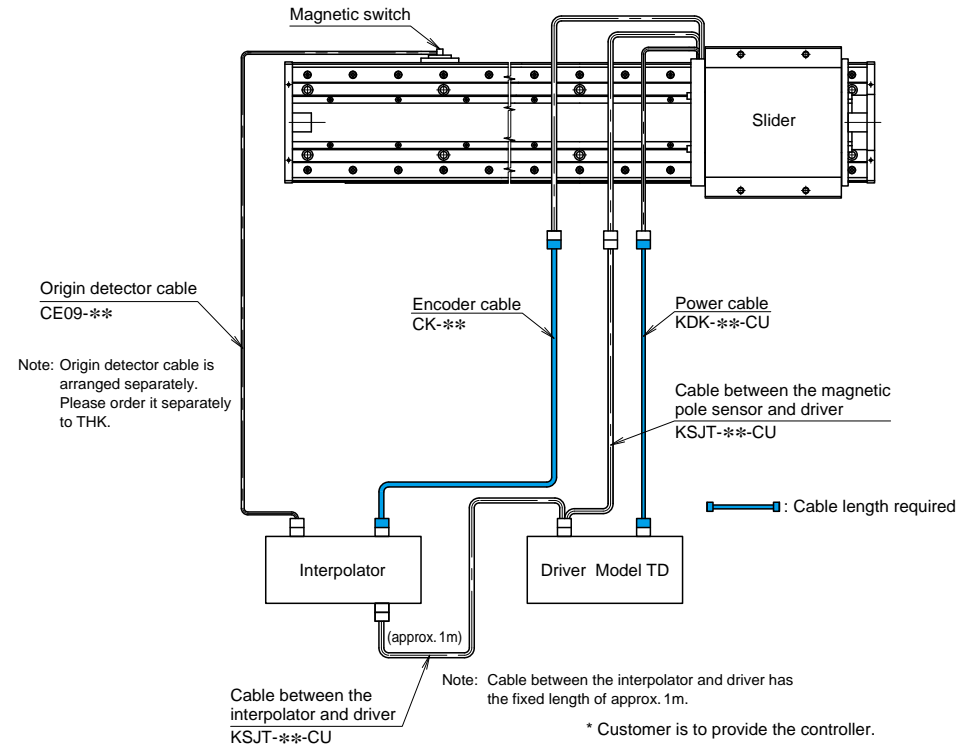

### Combinations of the power cable and encoder/magnetic pole sensor cables

Cable length required	Power cable model no. [model no. of the main unit]	Specifications without the magnetic pole sensor	
		Encoder cable model no. [model no. of the main unit]	Model no. of the cable between the interpolator and driver
1m	KDK-01-CU [D01]	CK-01 [E01]	KSET-01-CU
3m	KDK-03-CU [D03]	CK-03 [E03]	
5m	KDK-05-CU [D05]	CK-05 [E05]	
10m	KDK-10-CU [D10]	CK-10 [E10]	
15m	KDK-15-CU [D15]	CK-15 [E15]	

### Combinations of the power cable and encoder/magnetic pole sensor cables

Cable length required	Power cable model no. [model no. of the main unit]	Specifications with the magnetic pole sensor	
		Encoder cable model no. [model no. of the main unit]	Model no. of the cable between the interpolator and magnetic pole sensor/driver
1m	KDK-01-CU [D01]	No setting	No setting
3m	KDK-03-CU [D03]	CK-03 [E03]	KSJT-03-CU
5m	KDK-05-CU [D05]	CK-05 [E05]	KSJT-05-CU
10m	KDK-10-CU [D10]	CK-10 [E10]	KSJT-10-CU
15m	KDK-15-CU [D15]	CK-15 [E15]	KSJT-15-CU

Note: The table above is a standard combination of the cable length. If the combinations other than the table above is required, please contact THK.

## Dimensions S type: With the optical linear encoder (RENISHAW)

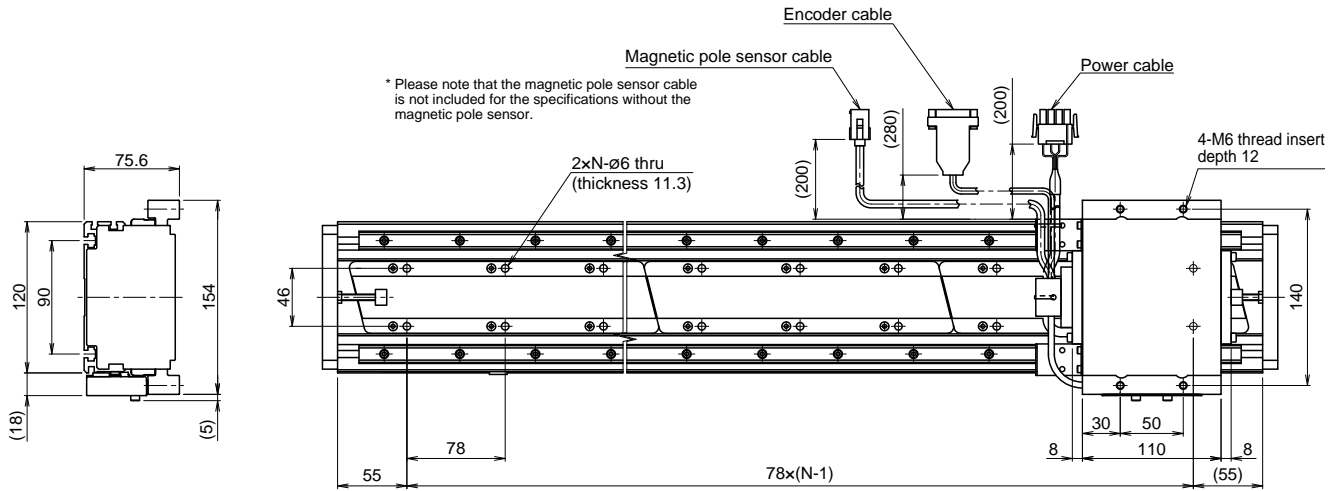

With magnetic pole sensor : 51  
Without magnetic pole sensor : 37

Base length: L <sub>0</sub> [mm]	No. of mounting holes per row N
500	6
734	9
968	12
1202	15
1436	18
1670	21
1904	24
2138	27
2372	30
2606	33
2840	36
3074	39

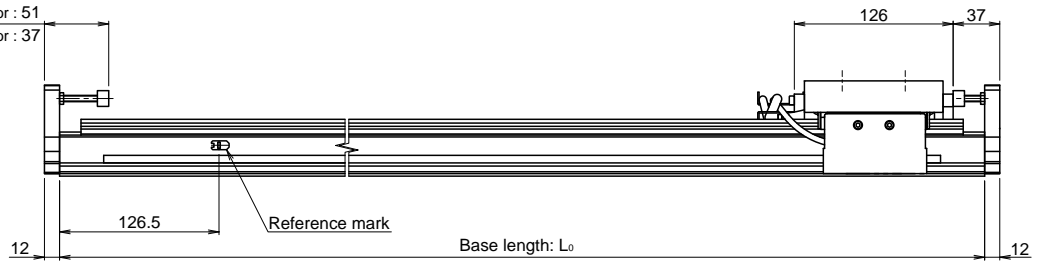

## Dimensions S type: With the magnetic linear encoder (Sony Manufacturing Systems)

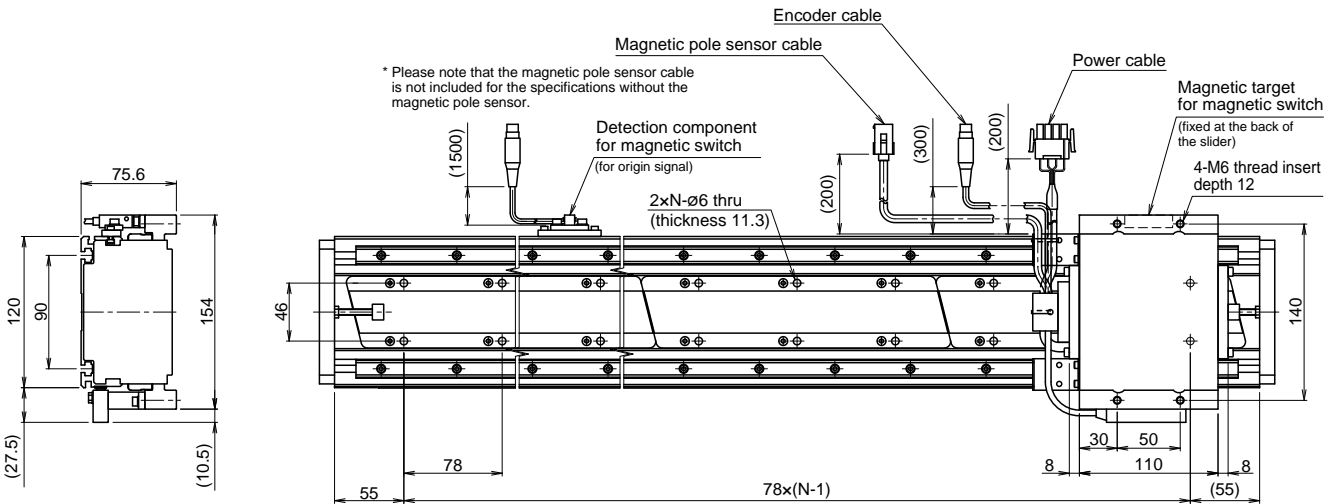

With magnetic pole sensor : 51  
Without magnetic pole sensor : 37

Base length: L <sub>0</sub> [mm]	No. of mounting holes per row N
500	6
734	9
968	12
1202	15
1436	18
1670	21
1904	24
2138	27
2372	30
2606	33
2840	36
3074	39

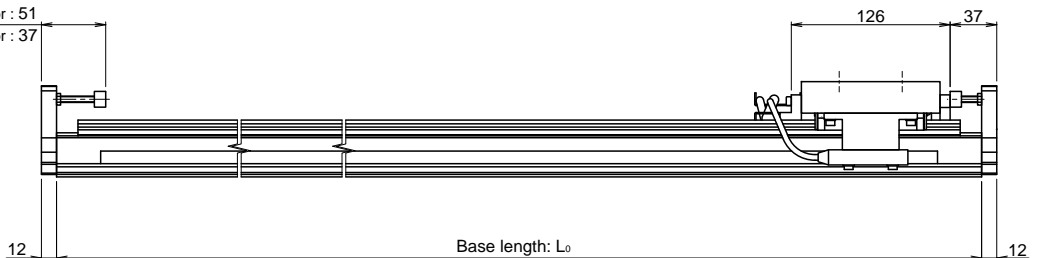

## Dimensions M type: With the optical linear encoder (RENISHAW)

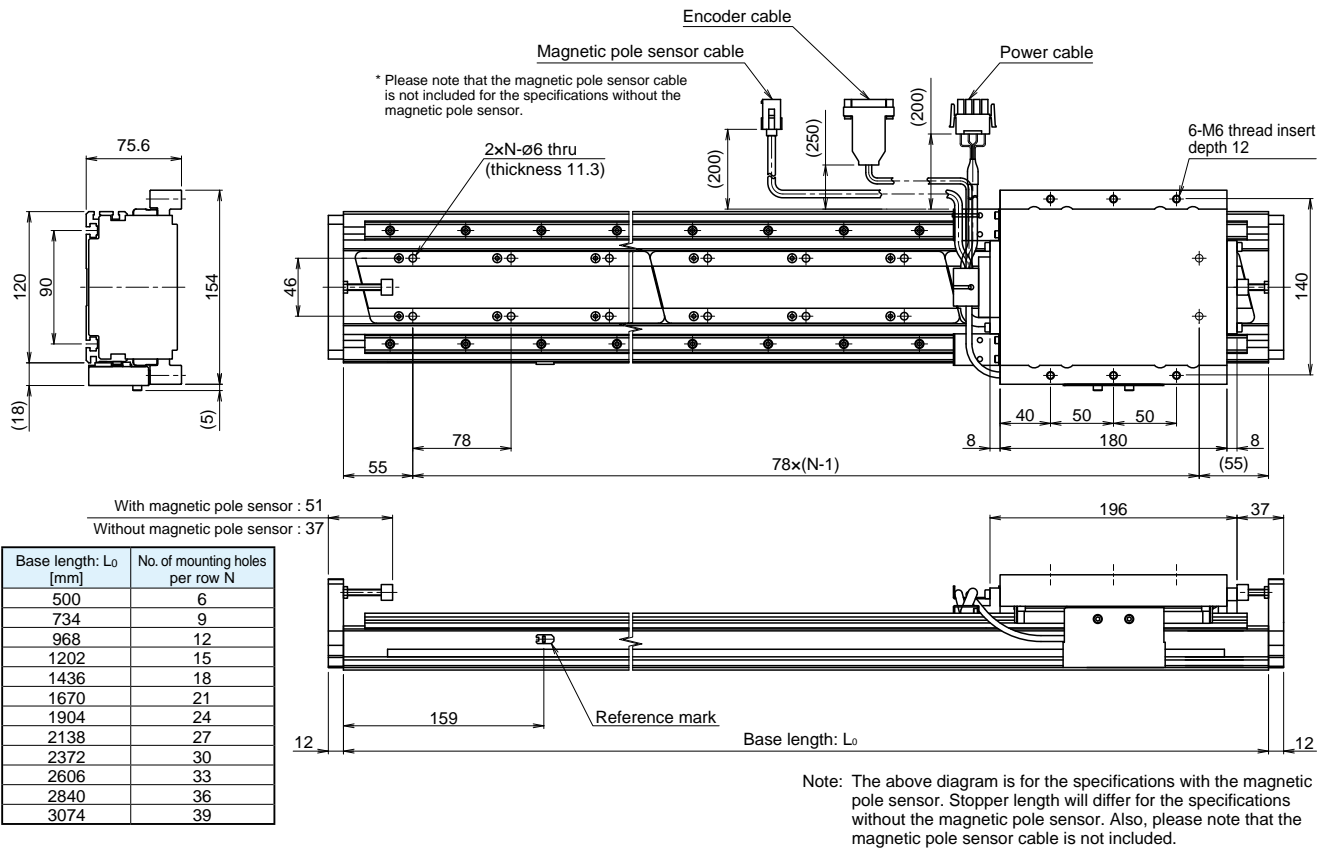

## Dimensions M type: With the magnetic linear encoder (Sony Manufacturing Systems)

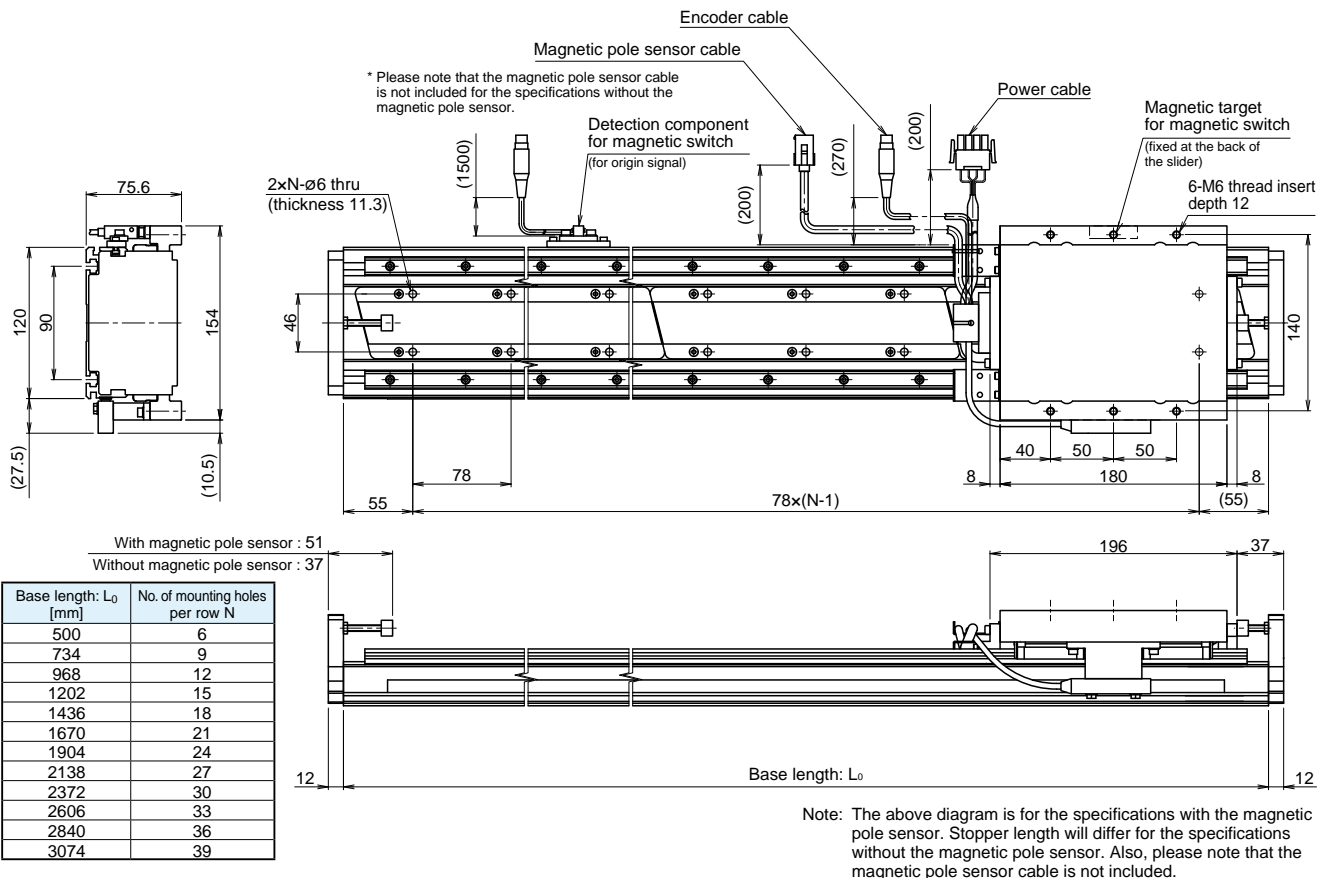

# Sensor/T-Slot/Cable Carrier Dimensions

## Proximity sensor

GL-12F [N.O. contact] (3pcs.) (SUNX)

GXL-N12F [N.O. contact] (1pc.) (SUNX)

GXL-N12FB [N.C. contact] (2pcs.)

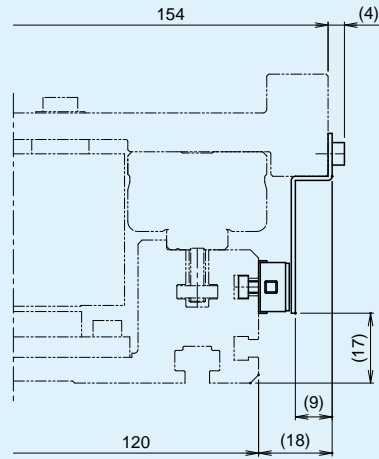

## Photo sensor

EE-SX671 + EE-1001

[Interchangeable for both N.O. and N.C. contact]  
(3pcs.) (OMRON)

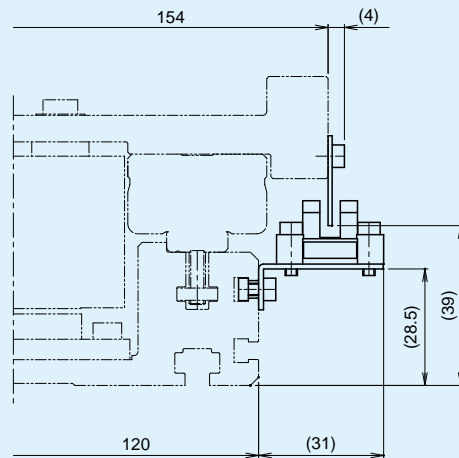

## T-slot

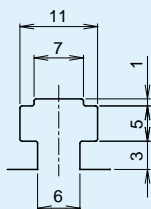

Dimensions of B section

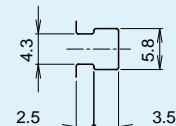
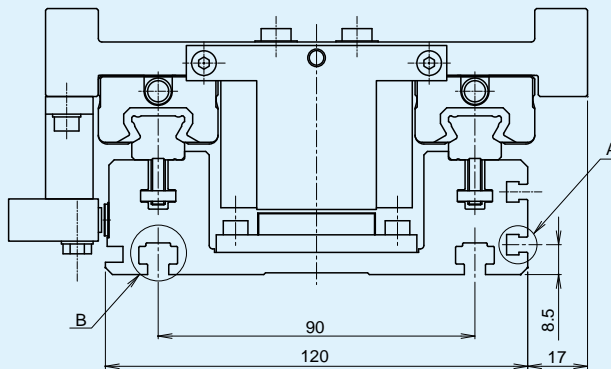

Dimensions of A section

GLM10

GLM15

GLM20

GLM25

Driver Model TD

## Standard cable carrier A

TKP0180W40R50 (Tsubakimoto Chain Co.)

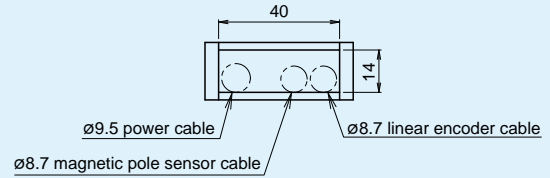
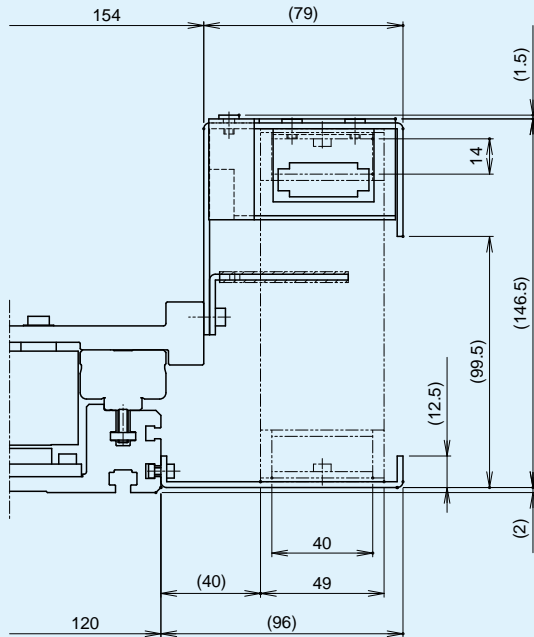

Cross section of the cable carrier

Note: It can be attached to the base length of up to 1904mm.

## Standard cable carrier C

E6.29.040.055.0 (IGUS)

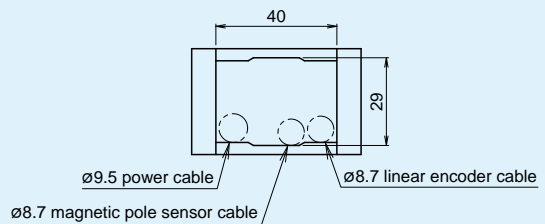
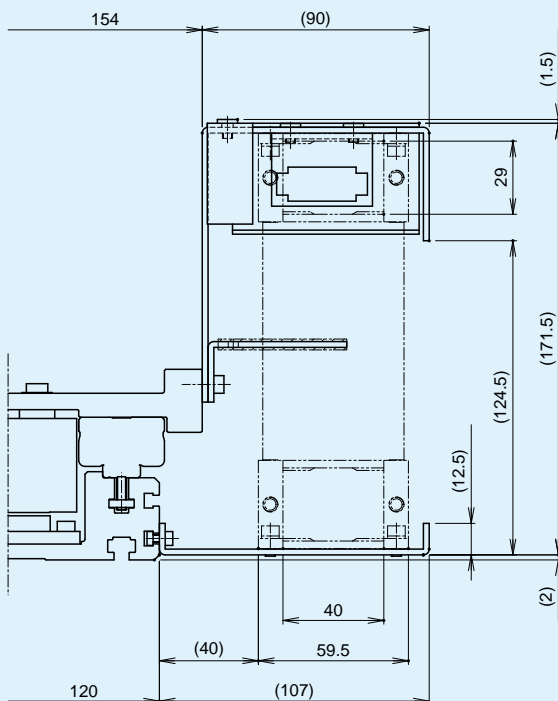

Cross section of the cable carrier

GLM10

GLM15

GLM20

GLM25

Driver Model TD

# Product Specifications

## Specifications

Item \ Motor type	S type								M type								L type			
Applicable driver	TD-045CU-200AC				TD-045CU-100AC				TD-075CU-200AC				TD-075CU-100AC				TD-100CU-200AC			
Main circuit power supply voltage	200VAC single-phase/three-phase				100VAC single-phase				200VAC single-phase/three-phase				100VAC single-phase				200VAC three-phase			
Maximum thrust [N] <sup>*1</sup>	333				285				612				481				933			
Rated continuous thrust [N] <sup>*1</sup>	59				48				113				124				178			
Maximum speed [m/s] <sup>*2</sup>	3.0	3.0	1.5	0.3	2.0	2.0	1.5	0.3	3.0	3.0	1.5	0.3	2.0	2.0	1.5	0.3	3.0	3.0	1.5	0.3
Resolution [μm]	10.0	1.0	0.5	0.1	10.0	1.0	0.5	0.1	10.0	1.0	0.5	0.1	10.0	1.0	0.5	0.1	10.0	1.0	0.5	0.1
Positioning repeatability [μm]	±10		±1		±10		±1		±10		±1		±10		±1		±10		±1	
Maximum load capacity [kg] <sup>*3</sup>	70								140								210			
Estimated mass [kg] <sup>*4</sup>	10								20								35			

\*1 This is the value in which the motor is driven with 100% of root-mean-square thrust under the condition with the ambient temperature of 20°C.

\*2 Maximum speed varies according to the linear scale resolution.

E.g.: Motor type - S type, selected driver - TD-045CU-200AC, resolution - 1.0μm, maximum speed - 3.0m/s

\*3 Speed and/or acceleration/deceleration may be restricted by the payload mass. See "Selection Method of Model GLM" on Pages 62 to 64.

\*4 Mass that can be driven with the acceleration of approx. 2G. However, operable weight may vary as it may be affected by thrust and speed characteristics depending on speed.

## Thrust - speed characteristics

### [200V main circuit power supply]

Motor type : S type  
Driver model no.: TD-045CU-200AC

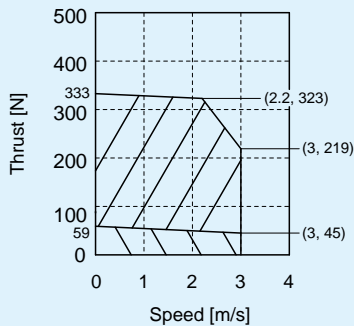

Motor type : M type  
Driver model no.: TD-075CU-200AC

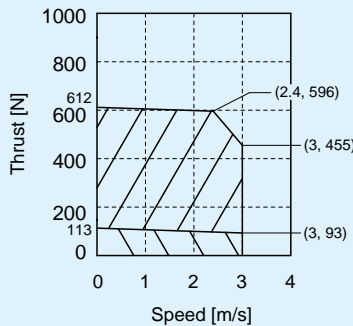

Motor type : L type  
Driver model no.: TD-100CU-200AC

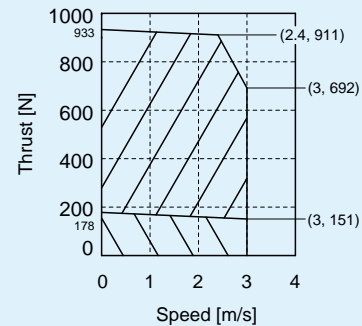

### [100V main circuit power supply]

Motor type : S type  
Driver model no.: TD-045CU-100AC

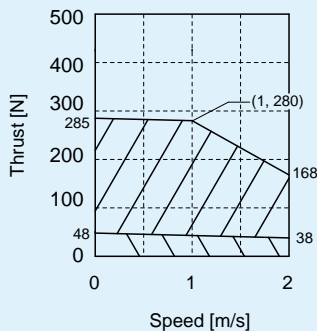

Motor type : M type  
Driver model no.: TD-075CU-100AC

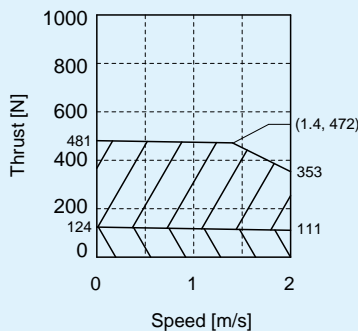

Maximum thrust  
Rated continuous thrust

## Base specifications

Item			Stroke between the mechanical stoppers: ST <sub>MAX</sub> [mm]								
Base length: L <sub>0</sub> [mm]	Base model no.	Base section mass [kg]	Motor type: S type			Motor type: M type			Motor type: L type		
			Without magnetic pole sensor	With magnetic pole sensor	With bellows	Without magnetic pole sensor	With magnetic pole sensor	With bellows	Without magnetic pole sensor	With magnetic pole sensor	With bellows
400	040	6.0	150 <sup>*1</sup>	140 <sup>*1</sup>	140 <sup>*1</sup>	30 <sup>*1</sup>	20 <sup>*1</sup>	60 <sup>*1</sup>	-	-	-
580	058	8.6	330	320	280	210 <sup>*1</sup>	200 <sup>*1</sup>	180 <sup>*1</sup>	90 <sup>*1</sup>	80 <sup>*1</sup>	100 <sup>*1</sup>
760	076	11.0	510	500	420	390	380	320	270 <sup>*1</sup>	260 <sup>*1</sup>	240 <sup>*1</sup>
940	094	13.6	690	680	540	570	560	460	450	440	360
1120	112	16.0	870	860	680	750	740	600	630	620	500
1300	130	18.6	1050	1040	820	930	920	720	810	800	640
1480	148	21.0	1230	1220	960	1110	1100	860	990	980	780
1660	166	23.6	1410	1400	1080	1290	1280	1000	1170	1160	900
1840	184	26.0	1590	1580	1220	1470	1460	1140	1350	1340	1040
2020	202	28.6	1770	1760	1360	1650	1640	1260	1530	1520	1180
2200	220	31.0	1950	1940	1500	1830	1820	1400	1710	1700	1320

\*1 When combined between short base length and long slider, some may not be able to use the base mounting hole in the central section.  
In this case, fix with the T-slot using the nuts for mounting the base (→ P.61).

Note 1: The stroke between the mechanical stoppers listed in the table above is for one slider.

Note 2: The standard length bases are recommended to conform to the standard magnet plate length.

Note 3: Maximum length of the single base is 4400mm.

GLM10

GLM15

GLM20

GLM25

Driver Model TD

# Model Number Chart

## Main unit

### 2 GLM20 - 220 - S - EP - C - PN - D - A - N - H - D05 - E05 - CU

① ② ③ ④ ⑤ ⑥ ⑦ ⑧ ⑨ ⑩ ⑪ ⑫ ⑬ ⑭

① Combined no. of sliders	* Omitted when the number is 1.
② Model no.	GLM20
③ Base model no.	* See "Model GLM20 Base specifications" (→ P.30).
④ Motor type (Slider size)	S : S type M : M type L : L type * See "Model GLM20 Specifications" (→ P.29).
⑤ End plate	EP : With standard end plate (both ends)
⑥ Cover	C : With aluminum plate cover N : No cover * The aluminum plate cover can be attached to the base length of up to 2200mm.
⑦ Resolution	* See "Model GLM20 Specifications" (→ P.29). Following types can be selected according to resolution. PN : Resolution 1.0μm (with the optical linear encoder) (RENISHAW) PU : Resolution 0.5μm (with the optical linear encoder) (RENISHAW) PV : Resolution 0.1μm (with the optical linear encoder) (RENISHAW) TD : Resolution 10.0μm (with the magnetic linear encoder) (Sony Manufacturing Systems) *1 The values of resolution are after quadrature. *2 With TD, the interpolator (waveform conversion unit) is attached.
⑧ Sensor	K : Proximity sensor GL-12F [N.O. contact] (3pcs.) (SUNX) D : Proximity sensor GXL-N12F [N.O. contact] (1pc.) (SUNX) GXL-N12FB [N.C. contact] (2pcs.) I : Photo sensor EE-SX671 [Interchangeable for both N.O. and N.C. contact] (3pcs.) (OMRON) N : No sensor
⑨ Cable carrier	A : TKP0180W40R50 (Tsubakimoto Chain Co.) Q : E6.29.040.055.0 (IGUS) N : No cable carrier <b>Note:</b> Main unit must come with a cable carrier in order for it to conform to UL Certifications and CE Marking. (Items conforming to CE Marking requirements have a protective cover on the cable connector) Also, please note that the main unit without the cable carrier only conforms to UL Certification. (If selecting the main unit without the cable carrier, the conforming product/certified product code ⑭ will be "UL".) * Cable carriers other than the standard equipment can also be selected. For more information, please contact THK.
⑩ Magnetic pole sensor	J : With magnetic pole sensor equipped N : No magnetic pole sensor * In case that the magnetic pole sensor is not equipped, when the power is turned on, automatic magnetic pole detection is executed when the first Servo-On command is sent. During the automatic magnetic pole detection, the slider will travel several millimeters back and forth for approximately 10 seconds. The item with the magnetic pole sensor must be selected in order to avoid this motion.

[The model number chart for the main unit continues on the next page]

⑪ Design no.	<p>N : For 100V  H : For 200V</p> <p>* If several sliders are combined on single axis base, the standard setting will be restricted. For more information, please contact THK.</p>
⑫ Power cable	<p>D00 : No power cable required  D01 : Cable length 1m  D03 : Cable length 3m  D05 : Cable length 5m  D10 : Cable length 10m  D15 : Cable length 15m</p> <p>Note: For the combinations of the power cable and encoder/magnetic pole sensor cables, see Pages 35 and 36.</p>
⑬ Encoder cable	<p>E00 : Encoder cable not required  E01 : Cable length 1m  E03 : Cable length 3m  E05 : Cable length 5m  E10 : Cable length 10m  E15 : Cable length 15m</p> <p>* When the resolution ⑦ is specified as PN, PU, or PV and the magnetic pole sensor code ⑩ is specified as N  ⇒ KET cable (specified length) is included.</p> <p>* When the resolution ⑦ is specified as PN, PU, or PV and the magnetic pole sensor code ⑩ is specified as J  ⇒ KJET cable (specified length) is included.</p> <p>* When the resolution ⑦ is specified as TD and the magnetic pole sensor code ⑩ is specified as N  ⇒ KSET cable (1m) and CK cable (specified length) are included. CE09 cable is not included.</p> <p>* When the resolution ⑦ is specified as TD and the magnetic pole sensor code ⑩ is specified as J  ⇒ KSJT cable (interpolator side - 1m/magnetic pole sensor side - specified length) and CK cable (specified length) are included. CE09 cable is not included.</p> <p>Note: For the combinations of the power cable and encoder/magnetic pole sensor cables, see Pages 35 and 36.</p>
⑭ Conforming product/ certified product code	<p>CU : UL Certified products &amp; CE Marked products  UL : UL Certified products only (without cable carrier)</p> <p>Note: Main unit must come with a cable carrier in order for it to conform to UL Certifications and CE Marking. (Items conforming to CE Marking requirements have a protective cover on the cable connector) Also, please note that the main unit without the cable carrier only conforms to UL Certification.</p>

**TD - 045CU - 200AC - G20SU - 1U - N**

①	②	③	④	⑤	⑥
① Model no.	TD	: Driver model code			
② Capacity	045CU	: 450W (for S type motor)			
	075CU	: 750W (for M type motor)			
	100CU	: 1kW (for L type motor)			
		* 1kW capacity driver is available only with the input power supply of three-phase 200VAC.			
③ Input power supply	100AC	: Single-phase 100VAC			
	200AC	: Single-phase/three-phase 200VAC			
④ Motor type	G20SU	: GLM20 S type			
	G20MU	: GLM20 M type			
	G20LU	: GLM20 L type			
⑤ Resolution (value + unit)	10U	: 10.0μm			
	1U	: 1.0μm			
	500N	: 0.5μm			
	100N	: 0.1μm			
⑥ Magnetic pole sensor	J	: With magnetic pole sensor equipped			
	N	: No magnetic sensor			

## Cable

- \*1 The model GLM20 comes with a power cable, the encoder cable, and the magnetic pole sensor cable. However, in case of the magnetic linear encoder (Sony Manufacturing Systems) specification, the origin detector cable, CE09-\*\*, is not included. See the model number chart below, and separately order from THK.
- \*2 When the cable is purchased separately for maintenance, specify the model numbers below according to the linear encoder type.

## • With the optical linear encoder (RENISHAW)

**K DT - 03 - CU**

①	②	③
① Model no.	K	: Cable model code
② Type	DT	: Power cable (standard length of the cable: 1m, 3m, 5m, 10m, 15m)
	ET	: Encoder cable (standard length of the cable: 1m, 3m, 5m, 10m, 15m)
	JET	: Encoder/magnetic pole sensor cable (standard length of the cable: 1m, 3m, 5m, 10m, 15m)
③ Cable length [Unit: m]	03	: 3m (please select from standard length)
		* If the cable other than the standard length is required, please contact THK.

[The model number chart for the cable continues on the next page]

- With the magnetic linear encoder (Sony Manufacturing Systems)

## K DT - 03 - CU

①                      ②                      ③

- ① Model no.                      K : Cable model code
- ② Type                              DT : Power cable  
(standard length of the cable: 1m, 3m, 5m, 10m, 15m)  
SET : Connection cable between the interpolator and driver  
(standard length of the cable: 1m)  
SJT : Connection cable between the interpolator and the driver when the  
magnetic pole sensor is equipped  
(standard length of the cable between the interpolator and the driver:  
1m fixed)  
(standard length of the cable between the magnetic pole sensor and  
the driver: 3m, 5m, 10m, 15m)
- ③ Cable length                      03 : 3m (please select from standard length)  
[Unit: m]                              \* If the cable other than the standard length is required, please contact THK.

## C K - 03

①                      ②                      ③

- ① Model no.                      C : Cable model code
- ② Type                              K : Encoder cable  
(standard length of the cable: 1m, 3m, 5m, 10m, 15m)  
E09 : Cable for the origin detector  
(standard length of the cable: 1m, 3m, 5m, 10m, 15m)
- ③ Cable length                      03 : 3m (please select from standard length)  
[Unit: m]                              \* If the cable other than the standard length is required, please contact THK.

## Setup support tool

## D - CON2

①    ②

- ① Model no.                      D : Setup support tool
- ② Type                              CON2 : Digital operator  
ASYS : PC communications software  
\* D-ASYS (PC communications software) can be downloaded from THK's technical support  
site after logging in. Technical support site: <https://tech.thk.com/>

- Communication cable (cable for connecting to PC when using D-ASYS)

## K232 - 01

①

- ① Cable length                      01 : 1m

## System configuration: With the optical linear encoder (RENISHAW)

Specifications without the magnetic pole sensor

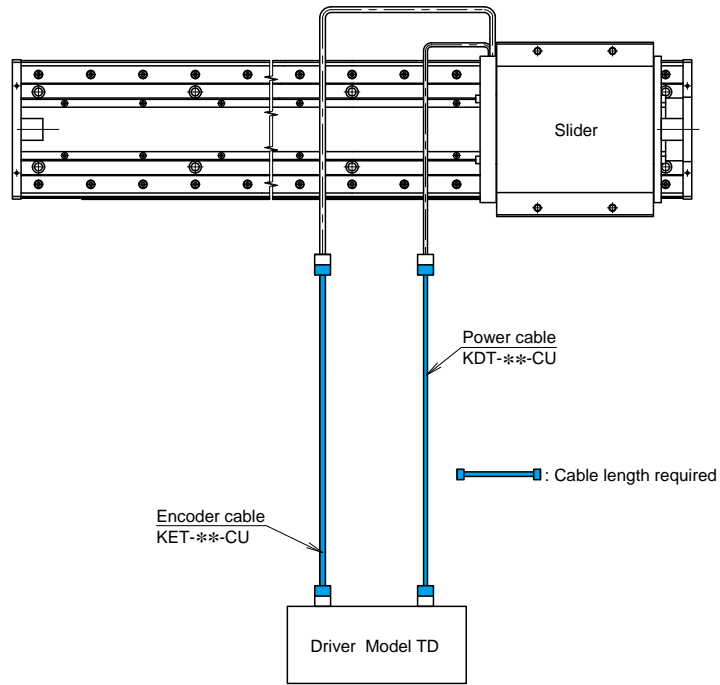

\* Customer is to provide the controller.

Specifications with the magnetic pole sensor

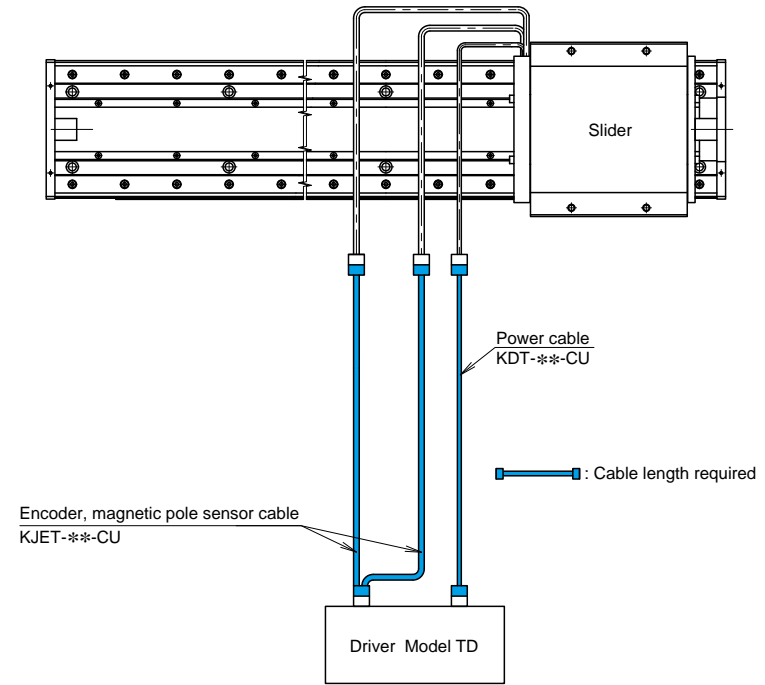

\* Customer is to provide the controller.

## ■ Combinations of the power cable and encoder/magnetic pole sensor cables

Cable length required	Power cable model no. [model no. of the main unit]	Specifications without the magnetic pole sensor	Specifications with the magnetic pole sensor
		Encoder cable model no. [model no. of the main unit]	Encoder/magnetic pole sensor cable model no. [model no. of the main unit]
1m	KDT-01-CU [D01]	KET-01-CU [E01]	KJET-01-CU [E01]
3m	KDT-03-CU [D03]	KET-03-CU [E03]	KJET-03-CU [E03]
5m	KDT-05-CU [D05]	KET-05-CU [E05]	KJET-05-CU [E05]
10m	KDT-10-CU [D10]	KET-10-CU [E10]	KJET-10-CU [E10]
15m	KDT-15-CU [D15]	KET-15-CU [E15]	KJET-15-CU [E15]

Note: The table above is a standard combination of the cable length. If the combinations other than the table above is required, please contact THK.

## System configuration: With the magnetic linear encoder (Sony Manufacturing Systems)

### Specifications without the magnetic pole sensor

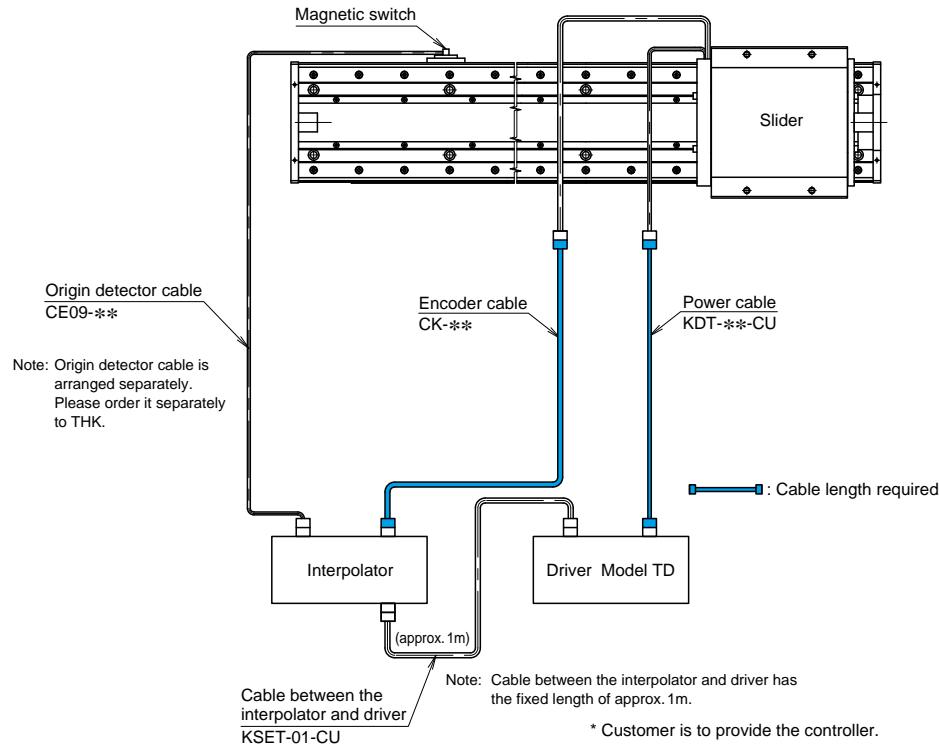

### Specifications with the magnetic pole sensor

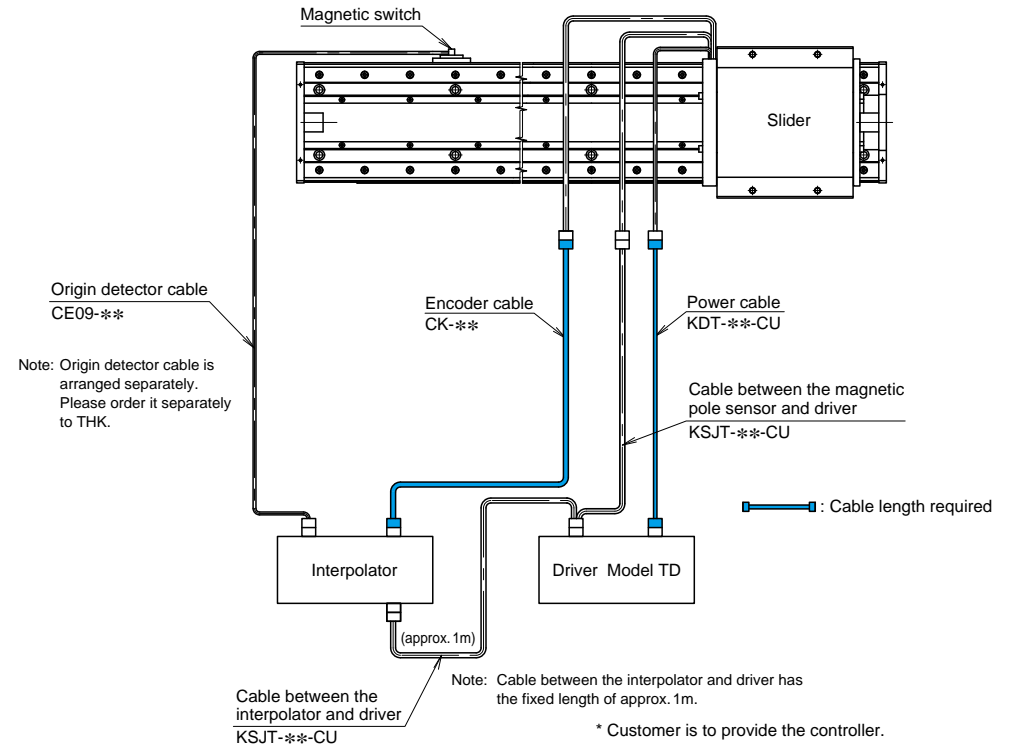

### Combinations of the power cable and encoder/magnetic pole sensor cables

Cable length required	Power cable model no. [model no. of the main unit]	Specifications without the magnetic pole sensor	
		Encoder cable model no. [model no. of the main unit]	Model no. of the cable between the interpolator and driver
1m	KDT-01-CU [D01]	CK-01 [E01]	KSET-01-CU
3m	KDT-03-CU [D03]	CK-03 [E03]	
5m	KDT-05-CU [D05]	CK-05 [E05]	
10m	KDT-10-CU [D10]	CK-10 [E10]	
15m	KDT-15-CU [D15]	CK-15 [E15]	

### Combinations of the power cable and encoder/magnetic pole sensor cables

Cable length required	Power cable model no. [model no. of the main unit]	Specifications with the magnetic pole sensor	
		Encoder cable model no. [model no. of the main unit]	Model no. of the cable between the interpolator and magnetic pole sensor/driver
1m	KDT-01-CU [D01]	No setting	No setting
3m	KDT-03-CU [D03]	CK-03 [E03]	KSJT-03-CU
5m	KDT-05-CU [D05]	CK-05 [E05]	KSJT-05-CU
10m	KDT-10-CU [D10]	CK-10 [E10]	KSJT-10-CU
15m	KDT-15-CU [D15]	CK-15 [E15]	KSJT-15-CU

Note: The table above is a standard combination of the cable length. If the combinations other than the table above is required, please contact THK.

## Dimensions S type: With the optical linear encoder (RENISHAW)

\* Please note that the magnetic pole sensor cable is not included for the specifications without the magnetic pole sensor.

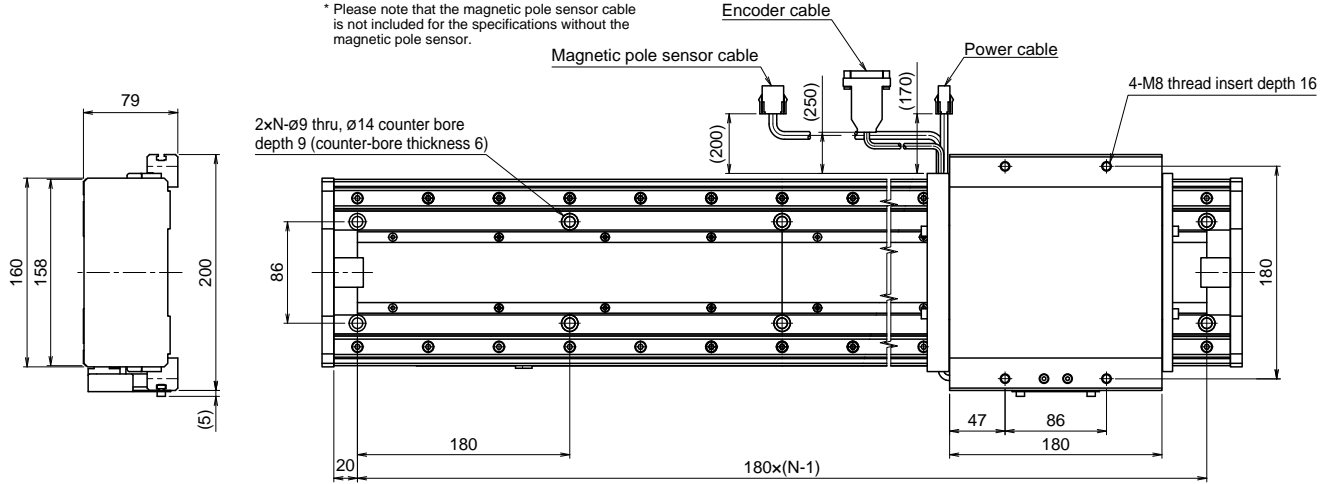

Base length: L <sub>0</sub> [mm]	No. of mounting holes per row N
400	3
580	4
760	5
940	6
1120	7
1300	8
1480	9
1660	10
1840	11
2020	12
2200	13

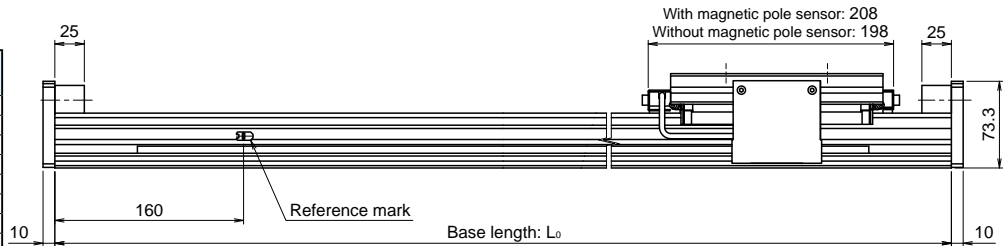

Note: The above diagram is for the specifications with the magnetic pole sensor. Slider length will differ for the specifications without the magnetic pole sensor. Also, please note that the magnetic pole sensor cable is not included.

## Dimensions S type: With the magnetic linear encoder (Sony Manufacturing Systems)

\*\* Please note that the total height of the resolution TD products is 80mm and this is different from the total height of the resolution PN, PU and PV products, which is 79mm.

\* Please note that the magnetic pole sensor cable is not included for the specifications without the magnetic pole sensor.

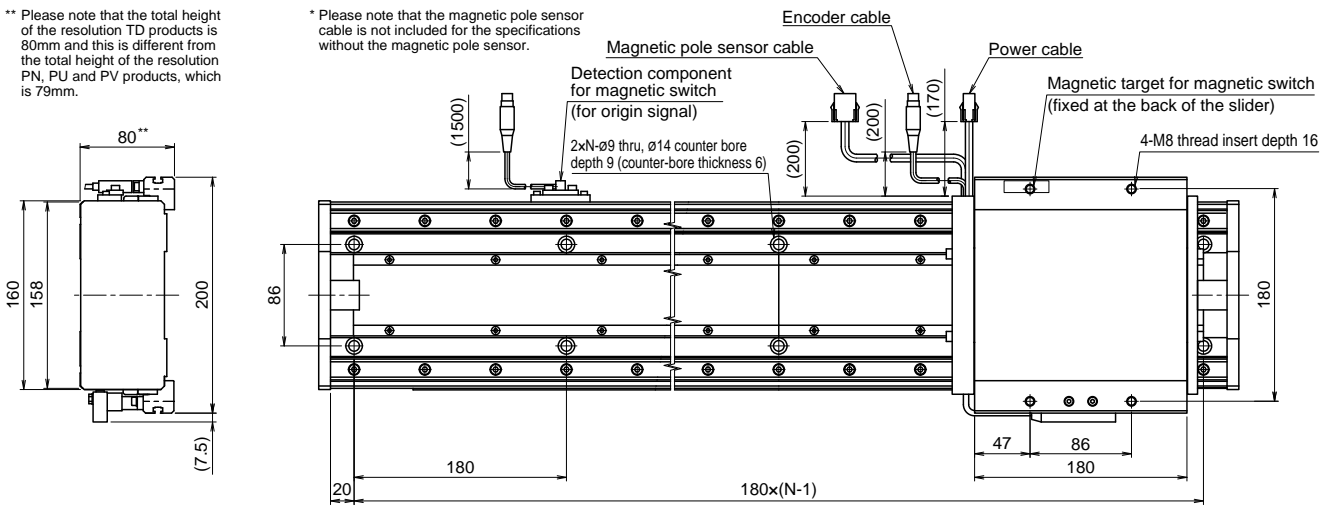

Base length: L <sub>0</sub> [mm]	No. of mounting holes per row N
400	3
580	4
760	5
940	6
1120	7
1300	8
1480	9
1660	10
1840	11
2020	12
2200	13

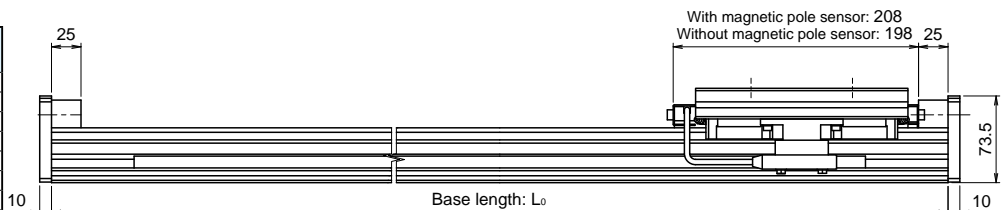

Note: The above diagram is for the specifications with the magnetic pole sensor. Slider length will differ for the specifications without the magnetic pole sensor. Also, please note that the magnetic pole sensor cable is not included.

## Dimensions M type: With the optical linear encoder (RENISHAW)

\* Please note that the magnetic pole sensor cable is not included for the specifications without the magnetic pole sensor.

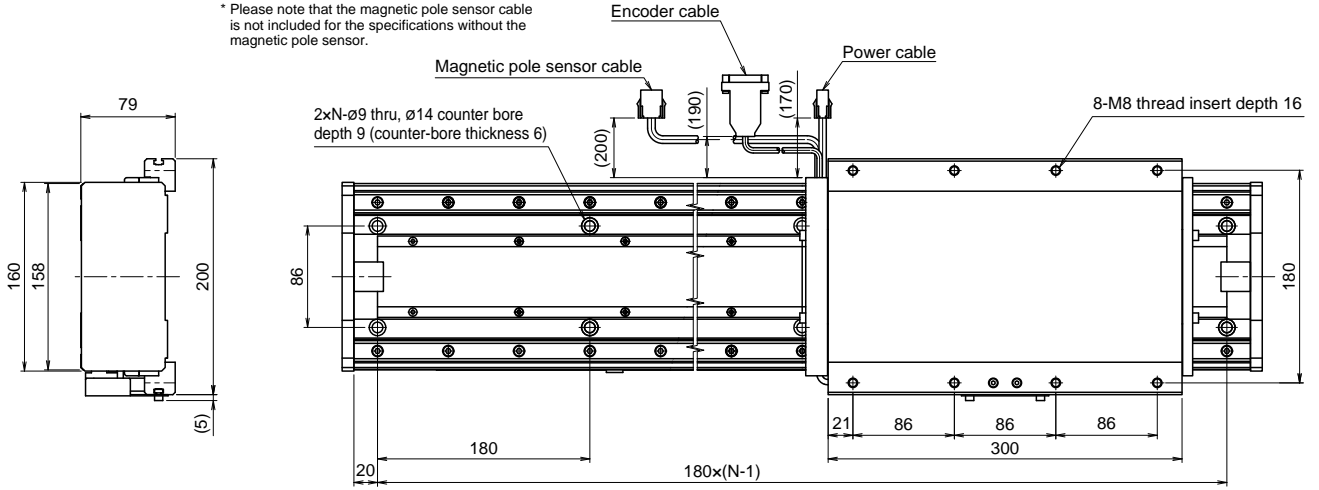

Base length: L <sub>0</sub> [mm]	No. of mounting holes per row N
400	3
580	4
760	5
940	6
1120	7
1300	8
1480	9
1660	10
1840	11
2020	12
2200	13

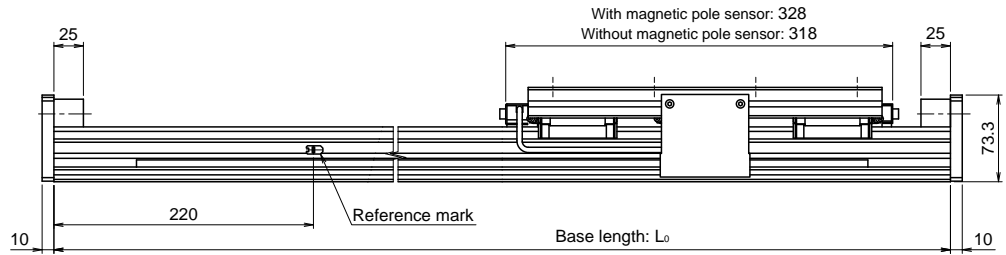

Note: The above diagram is for the specifications with the magnetic pole sensor. Slider length will differ for the specifications without the magnetic pole sensor. Also, please note that the magnetic pole sensor cable is not included.

## Dimensions M type: With the magnetic linear encoder (Sony Manufacturing Systems)

\*\* Please note that the total height of the resolution TD products is 80mm and this is different from the total height of the resolution PN, PU and PV products, which is 79mm.

\* Please note that the magnetic pole sensor cable is not included for the specifications without the magnetic pole sensor.

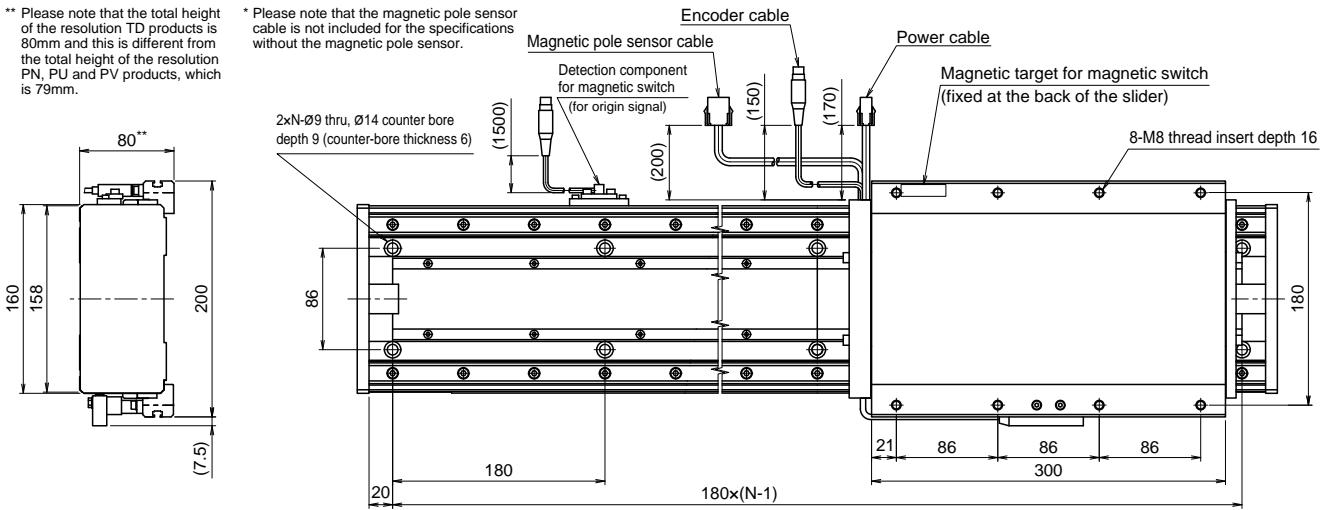

Base length: L <sub>0</sub> [mm]	No. of mounting holes per row N
400	3
580	4
760	5
940	6
1120	7
1300	8
1480	9
1660	10
1840	11
2020	12
2200	13

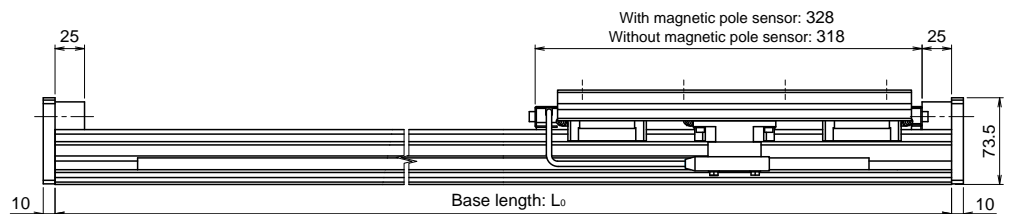

Note: The above diagram is for the specifications with the magnetic pole sensor. Slider length will differ for the specifications without the magnetic pole sensor. Also, please note that the magnetic pole sensor cable is not included.

## Dimensions L type: With the optical linear encoder (RENISHAW)

\* Please note that the magnetic pole sensor cable is not included for the specifications without the magnetic pole sensor.

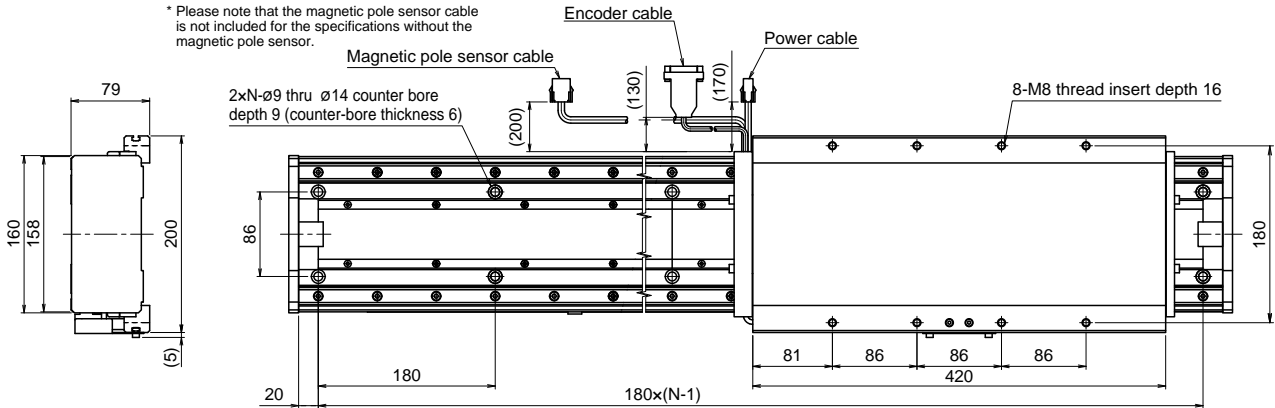

Base length: L <sub>0</sub> [mm]	No. of mounting holes per row N
580	4
760	5
940	6
1120	7
1300	8
1480	9
1660	10
1840	11
2020	12
2200	13

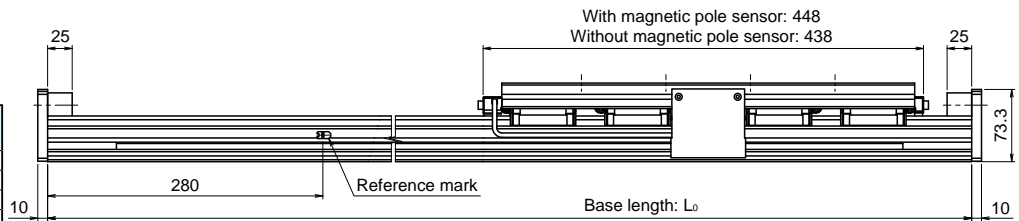

Note: The above diagram is for the specifications with the magnetic pole sensor. Slider length will differ for the specifications without the magnetic pole sensor. Also, please note that the magnetic pole sensor cable is not included.

## Dimensions L type: With the magnetic linear encoder (Sony Manufacturing Systems)

\*\* Please note that the total height of the resolution TD products is 80mm and this is different from the total height of the resolution PN, PU and PV products, which is 79mm.

\* Please note that the magnetic pole sensor cable is not included for the specifications without the magnetic pole sensor.

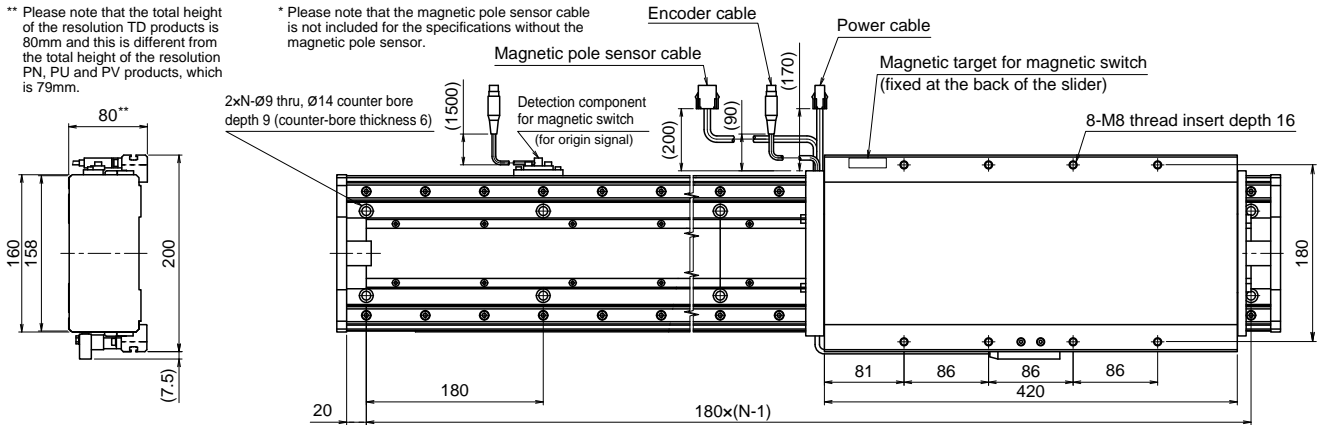

Base length: L <sub>0</sub> [mm]	No. of mounting holes per row N
580	4
760	5
940	6
1120	7
1300	8
1480	9
1660	10
1840	11
2020	12
2200	13

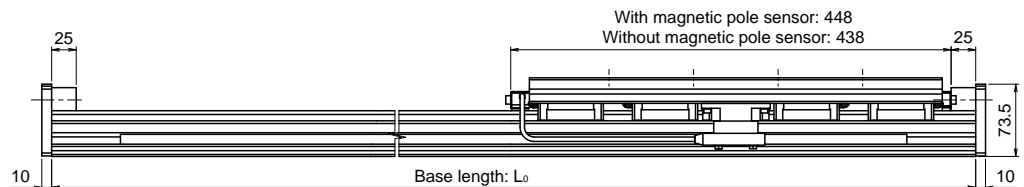

Note: The above diagram is for the specifications with the magnetic pole sensor. Slider length will differ for the specifications without the magnetic pole sensor. Also, please note that the magnetic pole sensor cable is not included.

# Sensor/T-Slot/Cable Carrier Dimensions

## Proximity sensor

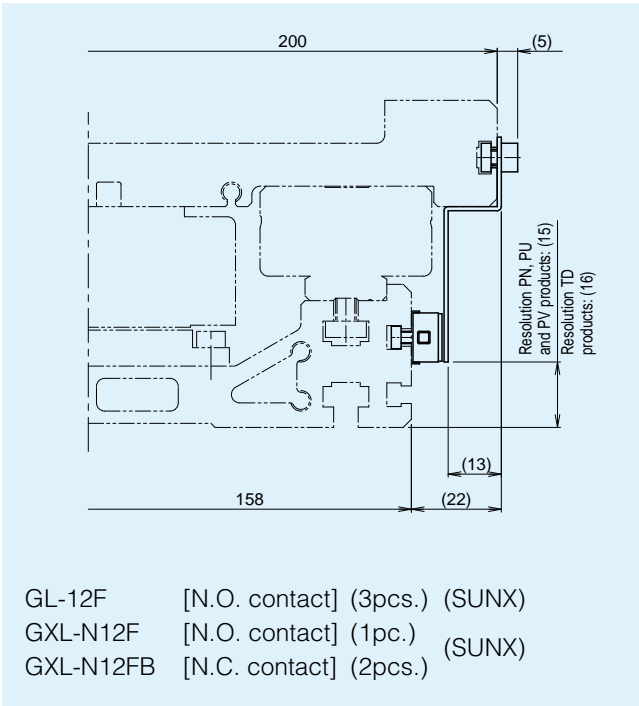

## Photo sensor

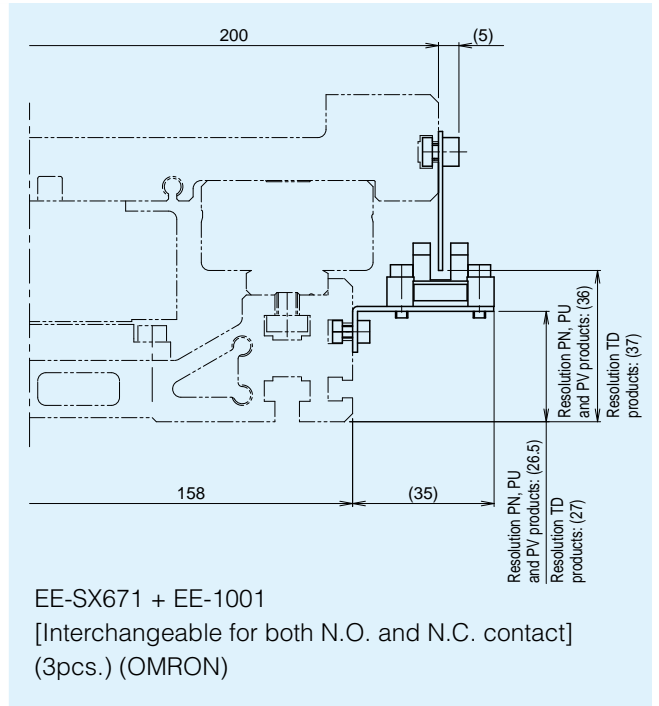

## T-slot

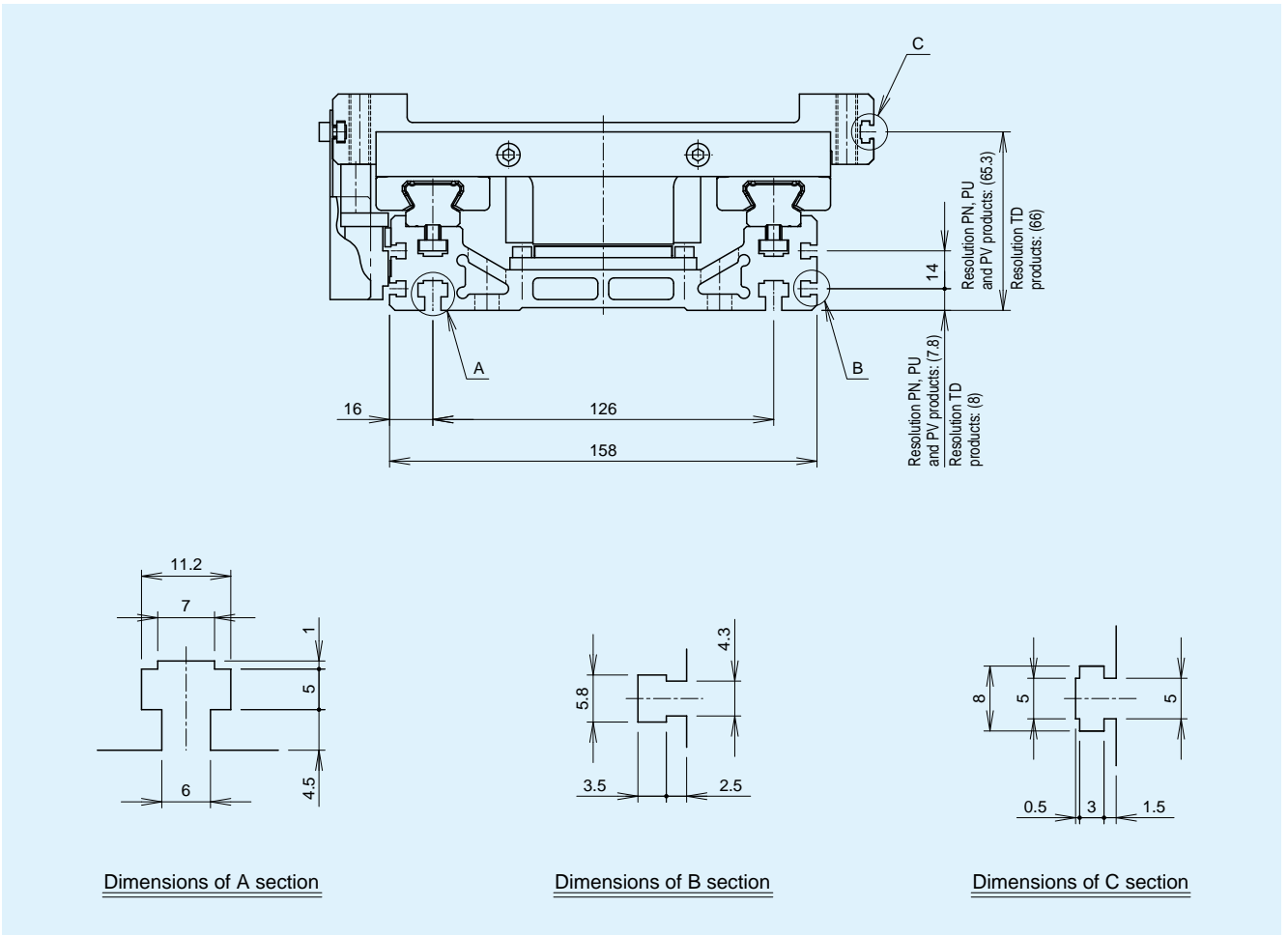

GLM10

GLM15

GLM20

GLM25

Driver Model TD

## Standard cable carrier A

TKP0180W40R50 (Tsubakimoto Chain Co.)

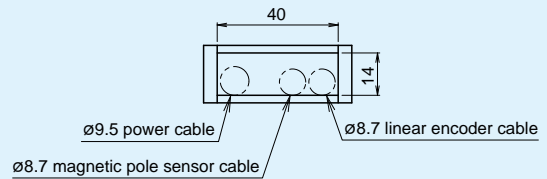
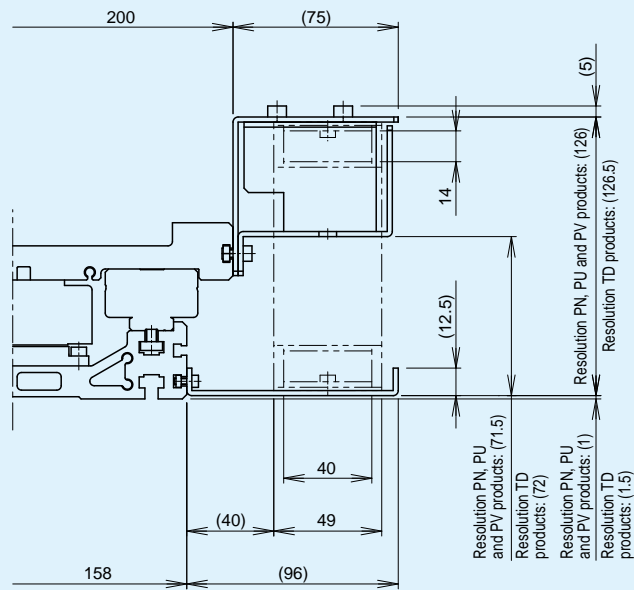

Cross section of the cable carrier

## Standard cable carrier Q

E6.29.040.055.0 (IGUS)

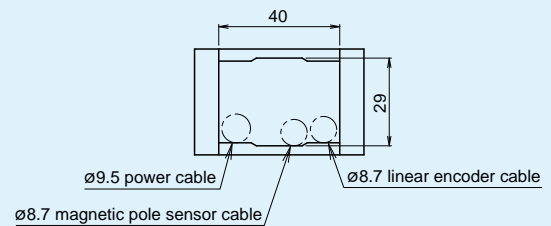
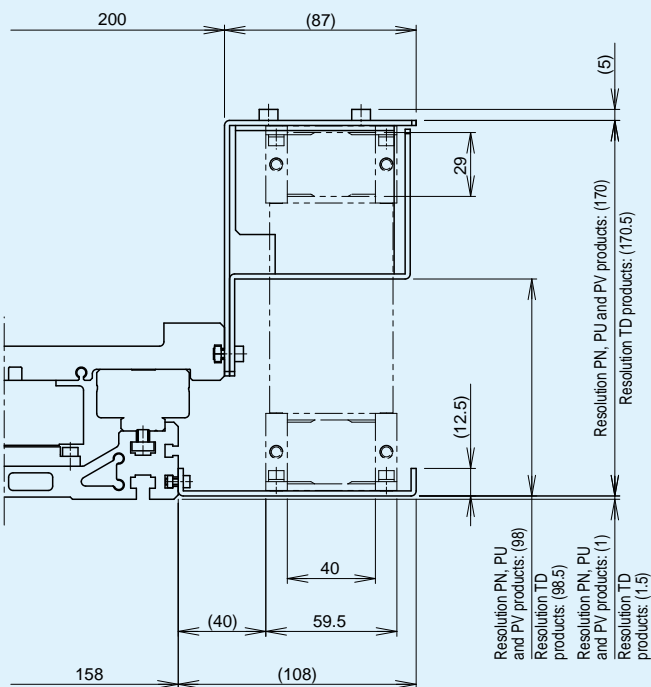

Cross section of the cable carrier

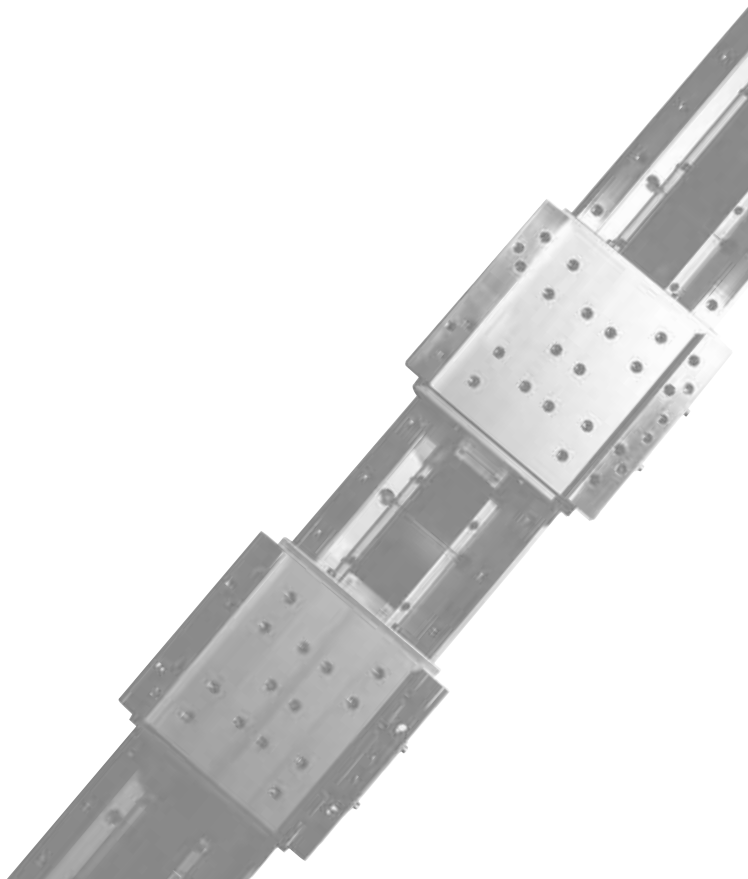

Driver Model TD

GLM25

GLM20

GLM15

GLM10

# Product Specifications

## Specifications

Item	S type				M type			
Applicable driver	TD-150CU-200AC				TD-300CU-200AC			
Main circuit power supply voltage	200VAC three-phase				200VAC three-phase			
Maximum thrust [N] <sup>*1</sup>	1557				3072			
Rated continuous thrust [N] <sup>*1</sup>	450				892			
Maximum speed [m/s] <sup>*2</sup>	3.0	3.0	1.5	0.3	3.0	3.0	1.5	0.3
Resolution [μm]	10	1.0	0.5	0.1	10	1.0	0.5	0.1
Positioning repeatability [μm]	±10	±1			±10	±1		
Maximum load capacity [kg] <sup>*3</sup>	193				415			
Estimated mass [kg] <sup>*4</sup>	28				52			

\*1 This is the value in which the motor is driven with 100% of root-mean-square thrust under the condition with the ambient temperature of 20°C.

\*2 Maximum speed varies according to the linear scale resolution.

E.g.: Motor type - S type, selected driver - TD-150CU-200AC, resolution - 1.0μm, maximum speed - 3.0m/s

\*3 Speed and/or acceleration/deceleration may be restricted by the payload mass. See "Selection Method of Model GLM" on Pages 62 to 64.

\*4 Mass that can be driven with the acceleration of approx. 2G. However, operable weight may vary as it may be affected by thrust and speed characteristics depending on speed.

## Thrust - speed characteristics

[200V main circuit power supply]

Motor type : S type  
Driver model no. : TD-150CU-200AC

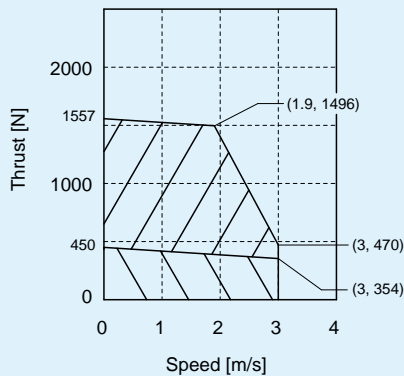

Motor type : M type  
Driver model no. : TD-300CU-200AC

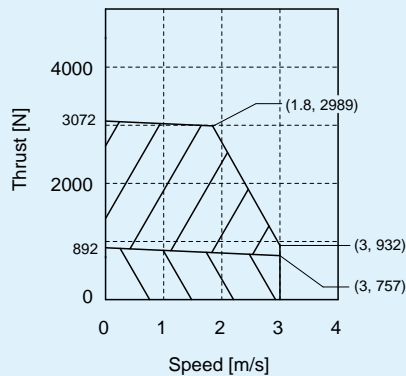

Maximum thrust

Rated continuous thrust

## Base specifications

Item			Stroke between the mechanical stoppers: ST <sub>MAX</sub> [mm]			
Base length: L <sub>0</sub> [mm]	Base model no.	Base section mass [kg]	Motor type: S type		Motor type: M type	
			Without magnetic pole sensor	With magnetic pole sensor	Without magnetic pole sensor	With magnetic pole sensor
545	055	22	285	265	-	-
701	070	27	441	421	-	-
857	086	32	597	577	407	402
1013	101	36	753	733	563	558
1169	117	41	909	889	719	714
1325	133	46	1065	1045	875	870
1481	148	50	1221	1201	1031	1026
1637	164	55	1377	1357	1187	1182
1793	179	60	1533	1513	1343	1338
1949	195	64	1689	1669	1499	1494
2105	211	69	1845	1825	1655	1650
2261	226	73	2001	1981	1811	1806
2417	242	78	2157	2137	1967	1962
2573	257	83	2313	2293	2123	2118
2729	273	87	2469	2449	2279	2274
2885	289	92	2625	2605	2435	2430
3041	304	96	2781	2761	2591	2586

Note 1: The stroke between the mechanical stoppers listed in the table above is for one slider.

Note 2: The standard length bases are recommended to conform to the standard magnet plate length.

Note 3: Maximum length of the single base is 3041mm.

GLM10

GLM15

GLM20

GLM25

Driver Model TD

# Model Number Chart

## Main unit

### 2 GLM25 - 101 - S - EP - C - NN - D - C - N - H - D03 - E03 - CU

① ② ③ ④ ⑤ ⑥ ⑦ ⑧ ⑨ ⑩ ⑪ ⑫ ⑬ ⑭

① Combined no. of sliders	* Omitted when the number is 1.
② Model no.	GLM25
③ Base model no.	* See "Model GLM25 Base specifications" (→P.44).
④ Motor type (Slider size)	S : S type M : M type * See "Model GLM25 Specifications" (→P.43).
⑤ End plate	EP : With standard end plate (both ends)
⑥ Cover	C : With aluminum plate cover N : No cover
⑦ Resolution	* See "Model GLM25 Specifications" (→P.43). Following types can be selected according to resolution. NN : Resolution 1.0μm (with the optical linear encoder) (RENISHAW) NU : Resolution 0.5μm (with the optical linear encoder) (RENISHAW) NV : Resolution 0.1μm (with the optical linear encoder) (RENISHAW) TD : Resolution 10.0μm (with the magnetic linear encoder) (Sony Manufacturing Systems) * The values of resolution are after quadrature. * With TD, the interpolator (waveform conversion unit) is attached.
⑧ Sensor	K : Proximity sensor GL-12F [N.O. contact] (3pcs.) (SUNX) D : Proximity sensor GXL-N12F [N.O. contact] (1pc.) (SUNX) GXL-N12FB [N.C. contact] (2pcs.) I : Photo sensor EE-SX671 [Interchangeable for both N.O. and N.C. contact] (3pcs.) (OMRON) N : No sensor
⑨ Cable carrier	Q : E6.29.040.055.0 (IGUS) N : No cable carrier Note: Main unit must come with a cable carrier in order for it to conform to UL Certifications and CE Marking. (Items conforming to CE Marking requirements have a protective cover on the cable connector) Also, please note that the main unit without the cable carrier only conforms to UL Certification. (If selecting the main unit without the cable carrier, the conforming product/certified product code ⑭ will be "UL".) * Cable carriers other than the standard equipment can also be selected. For more information, please contact THK.
⑩ Magnetic pole sensor	J : With magnetic pole sensor equipped N : No magnetic pole sensor * In case that the magnetic pole sensor is not equipped, when the power is turned on, automatic magnetic pole detection is executed when the first Servo-On command is sent. During the automatic magnetic pole detection, the slider will travel several millimeters back and forth for approximately 10 seconds. The item with the magnetic pole sensor must be selected in order to avoid this motion.

[The model number chart for the main unit continues on the next page]

⑪ Design no.	H : For 200V
⑫ Power cable	D00 : No power cable required D01 : Cable length 1m D03 : Cable length 3m D05 : Cable length 5m D10 : Cable length 10m D15 : Cable length 15m  Note: For the combinations of the power cable and encoder/magnetic pole sensor cables, see Pages 48 and 49.
⑬ Encoder cable	E00 : Encoder cable not required E01 : Cable length 1m E03 : Cable length 3m E05 : Cable length 5m E10 : Cable length 10m E15 : Cable length 15m  * When the resolution ⑦ is specified as NN, NU, or NV and the magnetic pole sensor code ⑩ is specified as N ⇒ KET cable (specified length) is included.  * When the resolution ⑦ is specified as NN, NU, or NV and the magnetic pole sensor code ⑩ is specified as J ⇒ KJET cable (specified length) is included.  * When the resolution ⑦ is specified as TD and the magnetic pole sensor code ⑩ is specified as N ⇒ KSET cable (1m) and CK cable (specified length) are included. CE09 cable is not included.  * When the resolution ⑦ is specified as TD and the magnetic pole sensor code ⑩ is specified as J ⇒ KSJT cable (interpolator side - 1m/magnetic pole sensor side - specified length) and CK cable (specified length) are included. CE09 cable is not included.  Note: For the combinations of the power cable and encoder/magnetic pole sensor cables, see Pages 48 and 49.
⑭ Conforming product/ certified product code	CU : UL Certified products & CE Marked products UL : UL Certified products only (without cable carrier)  Note: Main unit must come with a cable carrier in order for it to conform to UL Certifications and CE Marking. (Items conforming to CE Marking requirements have a protective cover on the cable connector) Also, please note that the main unit without the cable carrier only conforms to UL Certification.

## Driver

**TD - 150CU - 200AC - G25SU - 1U - N**

①	②	③	④	⑤	⑥
① Model no.	TD	: Driver model code			
② Capacity	150CU	: 1.5kW (for S type motor)			
	300CU	: 3.0kW (for M type motor)			
③ Input power	200AC	: three-phase 200VAC			
④ Motor type	G25SU	: GLM25 S type			
	G25MU	: GLM25 M type			
⑤ Resolution (value + unit)	10U	: 10.0μm			
	1U	: 1.0μm			
	500N	: 0.5μm			
	100N	: 0.1μm			
⑥ Magnetic pole sensor	J	: With magnetic pole sensor equipped			
	N	: No magnetic pole sensor			

- \*1 The model GLM25 comes with a power cable, the encoder cable, and the magnetic pole sensor cable. However, in case of the magnetic linear encoder (Sony Manufacturing Systems) specification, the origin detector cable, CE09-\*\*, is not included. See the model number chart below, and separately order from THK.
- \*2 When the cable is purchased separately for maintenance, specify the model numbers below according to the linear encoder type.

• With the optical linear encoder (RENISHAW)

**K DK - 03 - CU**

①                      ②                      ③

- ① Model no.                      K : Cable model code
- ② Type                      DK : Power cable (standard length of the cable: 1m, 3m, 5m, 10m, 15m)  
ET : Encoder cable (standard length of the cable: 1m, 3m, 5m, 10m, 15m)  
JET : Encoder/magnetic pole sensor cable  
(standard length of the cable: 1m, 3m, 5m, 10m, 15m)
- ③ Cable length                      03 : 3m (please select from standard length)  
[Unit: m]                      \* If the cable other than the standard length is required, please contact THK.

• With the magnetic linear encoder (Sony Manufacturing Systems)

**K DK - 03 - CU**

①                      ②                      ③

- ① Model no.                      K : Cable model code
- ② Type                      DK : Power cable  
(standard length of the cable: 1m, 3m, 5m, 10m, 15m)  
SET : Connection cable between the interpolator and driver  
(standard length of the cable: 1m)  
SJT : Connection cable between the interpolator and the driver when the  
magnetic pole sensor is equipped  
(standard length of the cable between the interpolator and the driver:  
1m fixed)  
(standard length of the cable between the magnetic pole sensor and  
the driver: 3m, 5m, 10m, 15m)
- ③ Cable length                      03 : 3m (please select from standard length)  
[Unit: m]                      \* If the cable other than the standard length is required, please contact THK.

**C K - 03**

①                      ②                      ③

- ① Model no.                      C : Cable model code
- ② Type                      K : Encoder cable  
(standard length of the cable: 1m, 3m, 5m, 10m, 15m)  
E09 : Cable for the origin detector  
(standard length of the cable: 1m, 3m, 5m, 10m, 15m)
- ③ Cable length                      03 : 3m (please select from standard length)  
[Unit: m]                      \* If the cable other than the standard length is required, please contact THK.

## D - CON2

①

②

① Model no.

D : Setup support tool

② Type

CON2 : Digital operator

ASYS : PC communications software

\* D-ASYS (PC communications software) can be downloaded from THK's technical support site after logging in. Technical support site: <https://tech.thk.com/>

- Communication cable (cable for connecting to PC when using D-ASYS)

## K232 - 01

①

① Cable length

01 : 1m

GLM10

GLM15

GLM20

GLM25

Driver Model TD

## System configuration: With the optical linear encoder (RENISHAW)

Specifications without the magnetic pole sensor

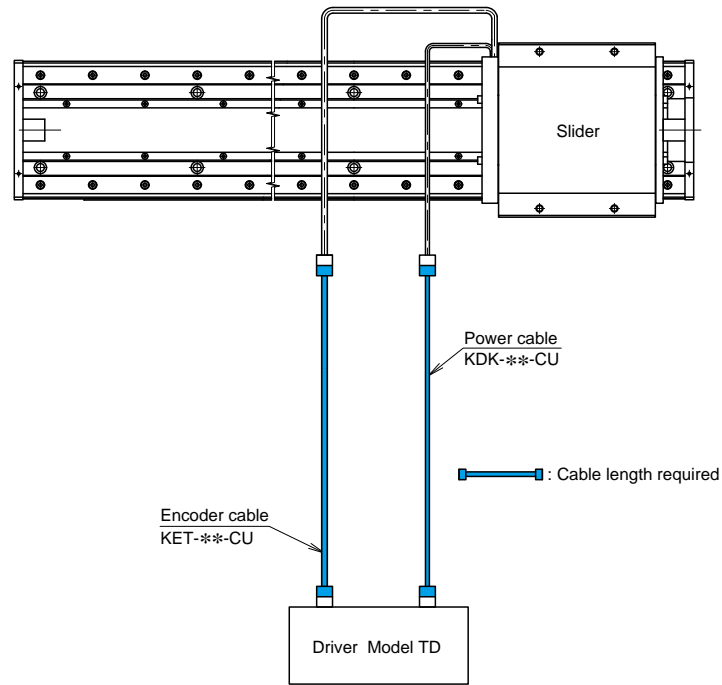

\* Customer is to provide the controller.

Specifications with the magnetic pole sensor

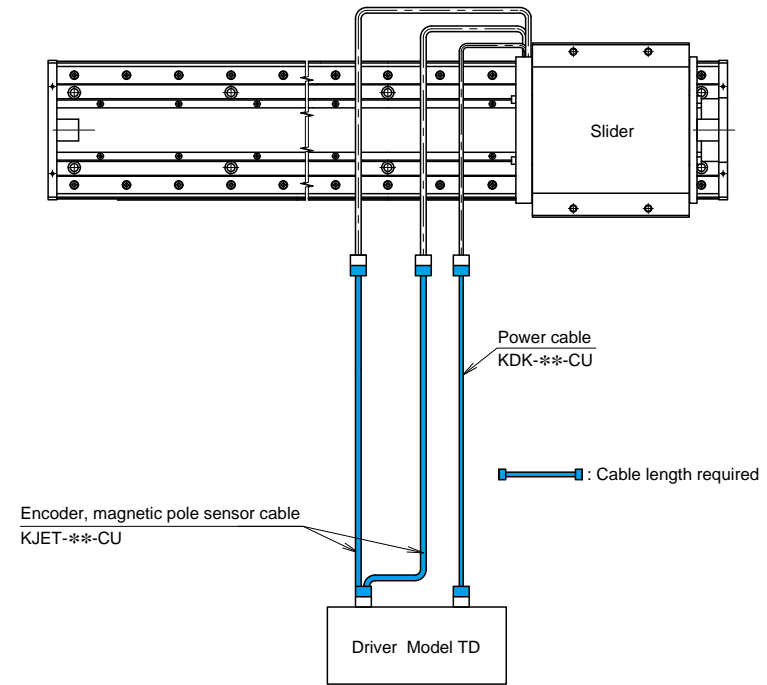

\* Customer is to provide the controller.

## ■ Combinations of the power cable and encoder/magnetic pole sensor cables

Cable length required	Power cable model no. [model no. of the main unit]	Specifications without the magnetic pole sensor	Specifications with the magnetic pole sensor
		Encoder cable model no. [model no. of the main unit]	Encoder/magnetic pole sensor cable model no. [model no. of the main unit]
1m	KDK-01-CU [D01]	KET-01-CU [E01]	KJET-01-CU [E01]
3m	KDK-03-CU [D03]	KET-03-CU [E03]	KJET-03-CU [E03]
5m	KDK-05-CU [D05]	KET-05-CU [E05]	KJET-05-CU [E05]
10m	KDK-10-CU [D10]	KET-10-CU [E10]	KJET-10-CU [E10]
15m	KDK-15-CU [D15]	KET-15-CU [E15]	KJET-15-CU [E15]

Note: The table above is a standard combination of the cable length. If the combinations other than the table above is required, please contact THK.

## System configuration: With the magnetic linear encoder (Sony Manufacturing Systems)

### Specifications without the magnetic pole sensor

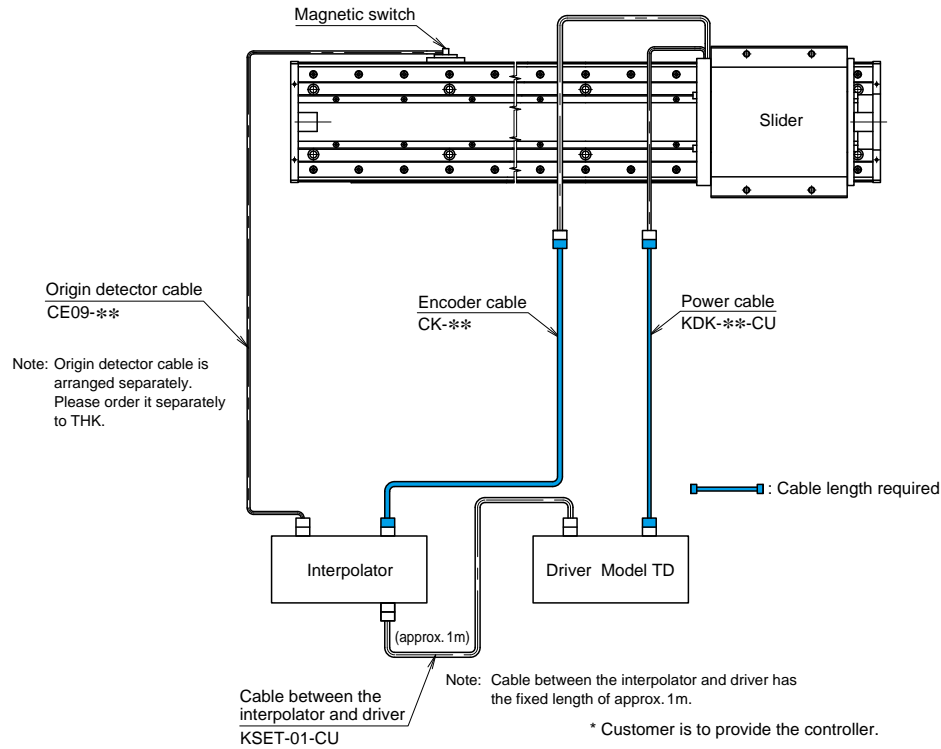

### Specifications with the magnetic pole sensor

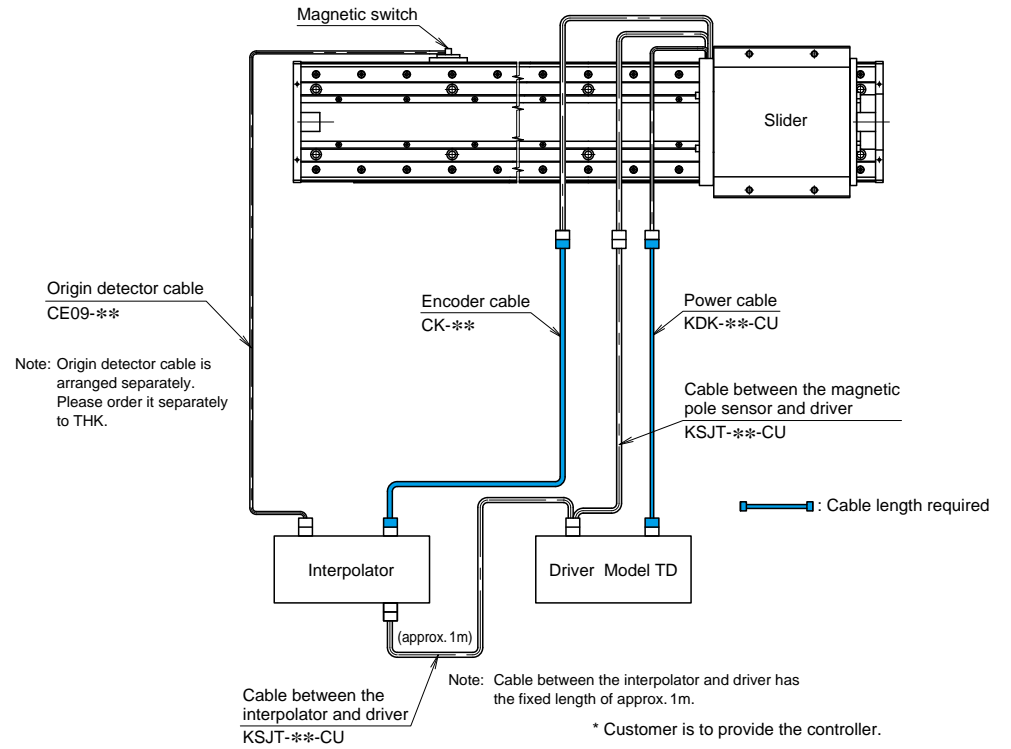

### Combinations of the power cable and encoder/magnetic pole sensor cables

Cable length required	Power cable model no. [model no. of the main unit]	Specifications without the magnetic pole sensor	
		Encoder cable model no. [model no. of the main unit]	Model no. of the cable between the interpolator and driver
1m	KDK-01-CU [D01]	CK-01 [E01]	KSET-01-CU
3m	KDK-03-CU [D03]	CK-03 [E03]	
5m	KDK-05-CU [D05]	CK-05 [E05]	
10m	KDK-10-CU [D10]	CK-10 [E10]	
15m	KDK-15-CU [D15]	CK-15 [E15]	

### Combinations of the power cable and encoder/magnetic pole sensor cables

Cable length required	Power cable model no. [model no. of the main unit]	Specifications with the magnetic pole sensor	
		Encoder cable model no. [model no. of the main unit]	Model no. of the cable between the interpolator and magnetic pole sensor/driver
1m	KDK-01-CU [D01]	No setting	No setting
3m	KDK-03-CU [D03]	CK-03 [E03]	KSJT-03-CU
5m	KDK-05-CU [D05]	CK-05 [E05]	KSJT-05-CU
10m	KDK-10-CU [D10]	CK-10 [E10]	KSJT-10-CU
15m	KDK-15-CU [D15]	CK-15 [E15]	KSJT-15-CU

Note: The table above is a standard combination of the cable length. If the combinations other than the table above is required, please contact THK.

## Dimensions S type: With the optical linear encoder (RENISHAW)

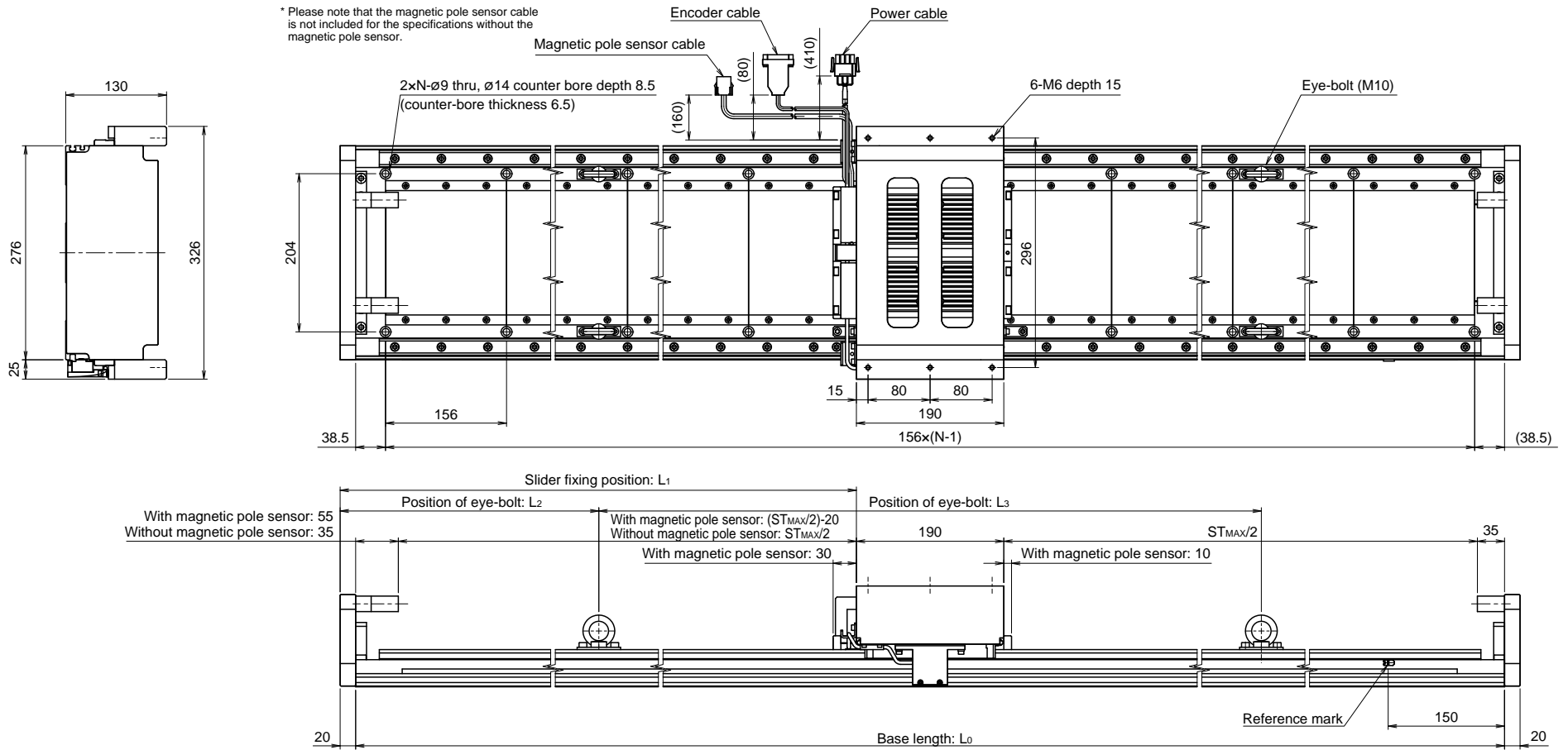

Note: The above diagram is for the specifications with the magnetic pole sensor. Stopper length and stroke between the mechanical stoppers will differ for the specifications without the magnetic pole sensor. Also, please note that the magnetic pole sensor cable is not included.

Base length: $L_0$ [mm]	No. of mounting holes per row: N	Slider fixing position $L_1$ [mm]	Position of eye-bolt $L_2$ [mm]	Position of eye-bolt $L_3$ [mm]
545	4	197.5	135.5	314
701	5	275.5	168.5	404
857	6	353.5	180.5	536
1013	7	431.5	222.5	608
1169	8	509.5	267.5	674
1325	9	587.5	300	765
1481	10	665.5	333.5	854
1637	11	743.5	366.5	944
1793	12	821.5	404	1025

Base length: $L_0$ [mm]	No. of mounting holes per row: N	Slider fixing position $L_1$ [mm]	Position of eye-bolt $L_2$ [mm]	Position of eye-bolt $L_3$ [mm]
1949	13	899.5	432.5	1124
2105	14	977.5	465.5	1214
2261	15	1055.5	493	1315
2417	16	1133.5	531.5	1394
2573	17	1211.5	564.5	1484
2729	18	1289.5	597.5	1574
2885	19	1367.5	630.5	1664
3041	20	1445.5	675	1731

## Dimensions S type: With the magnetic linear encoder (Sony Manufacturing Systems)

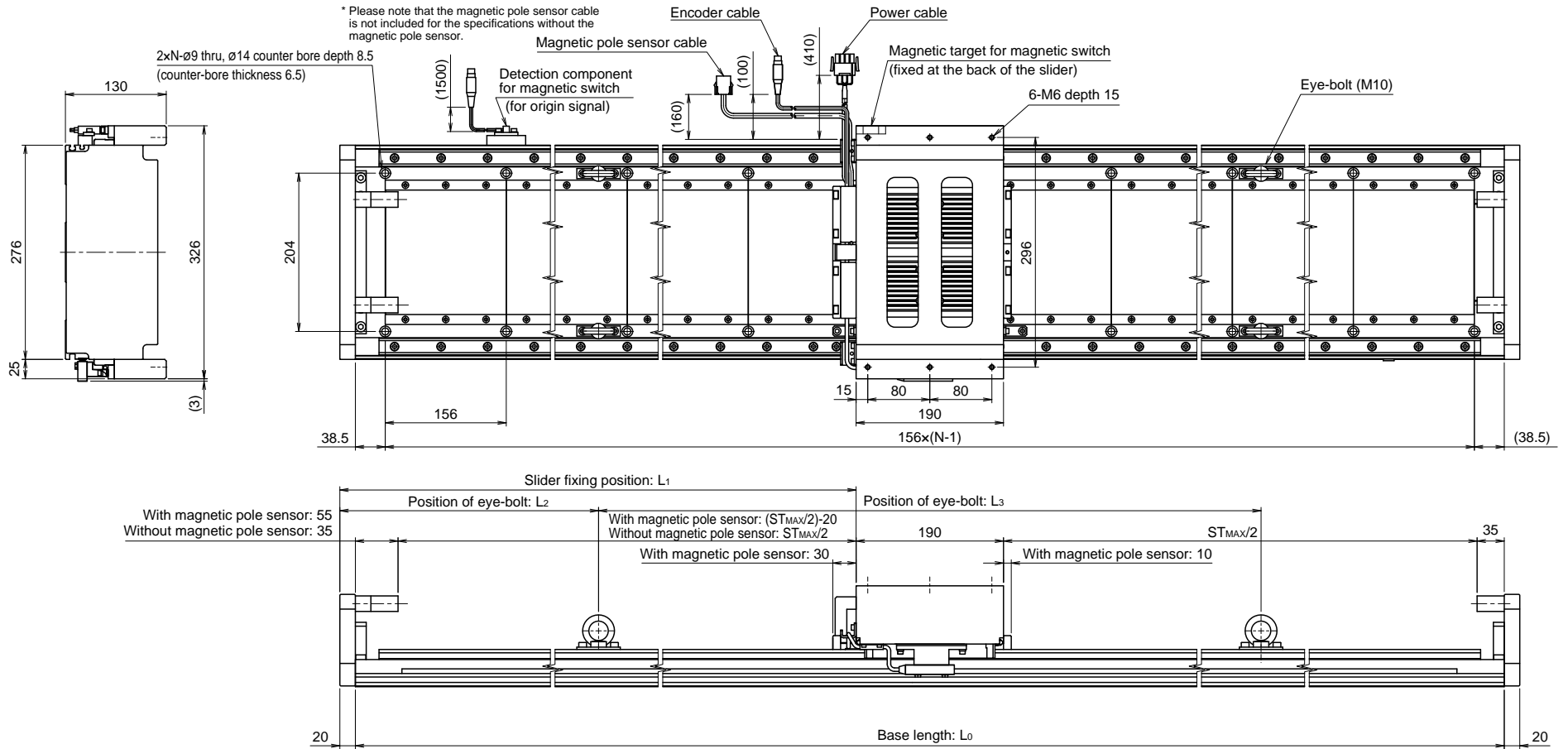

Note: The above diagram is for the specifications with the magnetic pole sensor. Stopper length and stroke between the mechanical stoppers will differ for the specifications without the magnetic pole sensor. Also, please note that the magnetic pole sensor cable is not included.

Base length: L <sub>0</sub> [mm]	No. of mounting holes per row: N	Slider fixing position L <sub>1</sub> [mm]	Position of eye-bolt L <sub>2</sub> [mm]	Position of eye-bolt L <sub>3</sub> [mm]
545	4	197.5	135.5	314
701	5	275.5	168.5	404
857	6	353.5	180.5	536
1013	7	431.5	222.5	608
1169	8	509.5	267.5	674
1325	9	587.5	300	765
1481	10	665.5	333.5	854
1637	11	743.5	366.5	944
1793	12	821.5	404	1025

Base length: L <sub>0</sub> [mm]	No. of mounting holes per row: N	Slider fixing position L <sub>1</sub> [mm]	Position of eye-bolt L <sub>2</sub> [mm]	Position of eye-bolt L <sub>3</sub> [mm]
1949	13	899.5	432.5	1124
2105	14	977.5	465.5	1214
2261	15	1055.5	493	1315
2417	16	1133.5	531.5	1394
2573	17	1211.5	564.5	1484
2729	18	1289.5	597.5	1574
2885	19	1367.5	630.5	1664
3041	20	1445.5	675	1731

## Dimensions M type: With the optical linear encoder (RENISHAW)

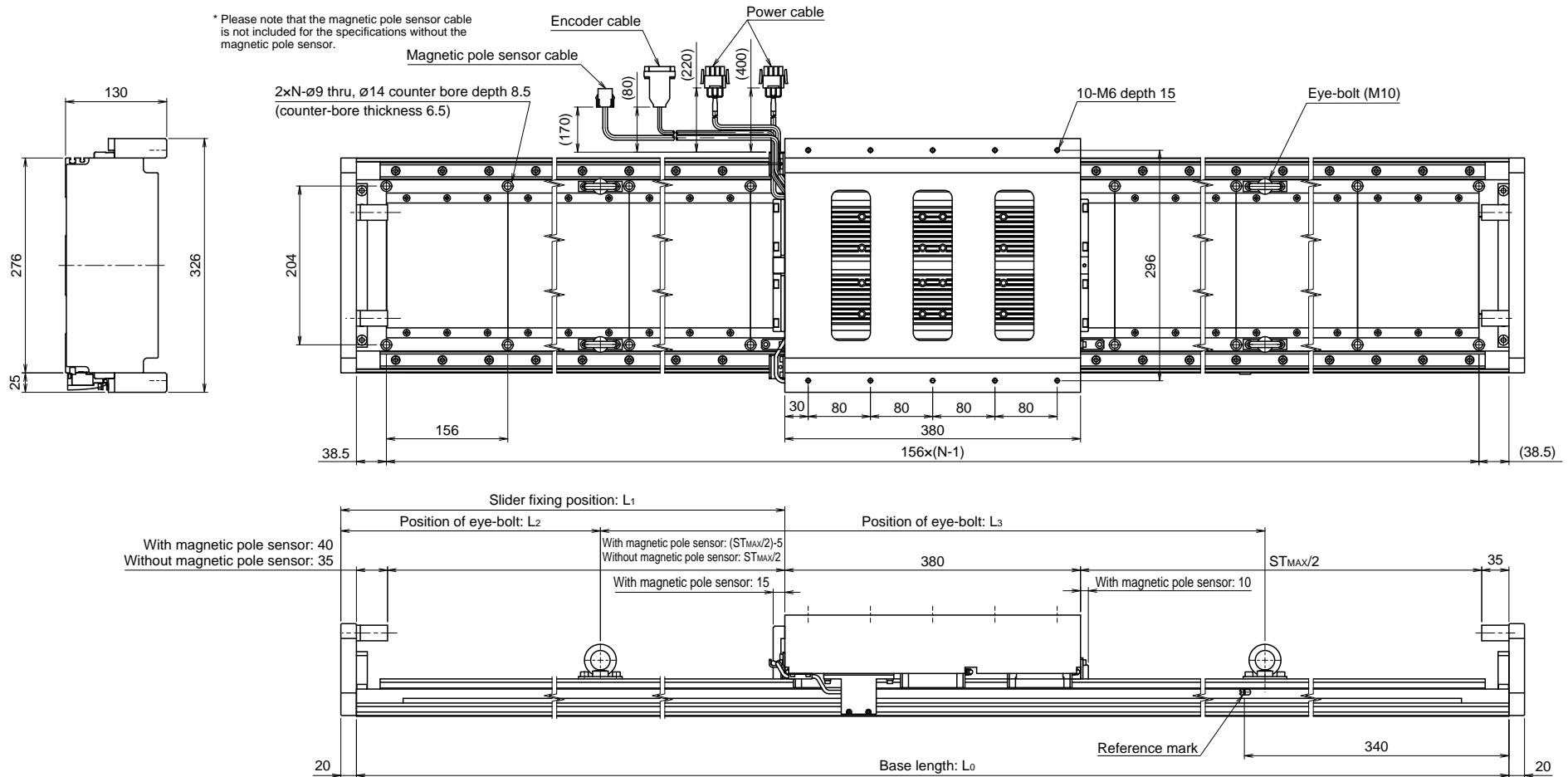

Note: The above diagram is for the specifications with the magnetic pole sensor. Stopper length and stroke between the mechanical stoppers will differ for the specifications without the magnetic pole sensor. Also, please note that the magnetic pole sensor cable is not included.

Base length: $L_0$ [mm]	No. of mounting holes per row: N	Slider fixing position $L_1$ [mm]	Position of eye-bolt $L_2$ [mm]	Position of eye-bolt $L_3$ [mm]
857	6	258.5	180.5	536
1013	7	336.5	222.5	608
1169	8	414.5	267.5	674
1325	9	492.5	300	765
1481	10	570.5	333.5	854
1637	11	648.5	366.5	944
1793	12	726.5	404	1025
1949	13	804.5	432.5	1124

Base length: $L_0$ [mm]	No. of mounting holes per row: N	Slider fixing position $L_1$ [mm]	Position of eye-bolt $L_2$ [mm]	Position of eye-bolt $L_3$ [mm]
2105	14	882.5	465.5	1214
2261	15	960.5	493	1315
2417	16	1038.5	531.5	1394
2573	17	1116.5	564.5	1484
2729	18	1194.5	597.5	1574
2885	19	1272.5	630.5	1664
3041	20	1350.5	675	1731

## Dimensions M type: With the magnetic linear encoder (Sony Manufacturing Systems)

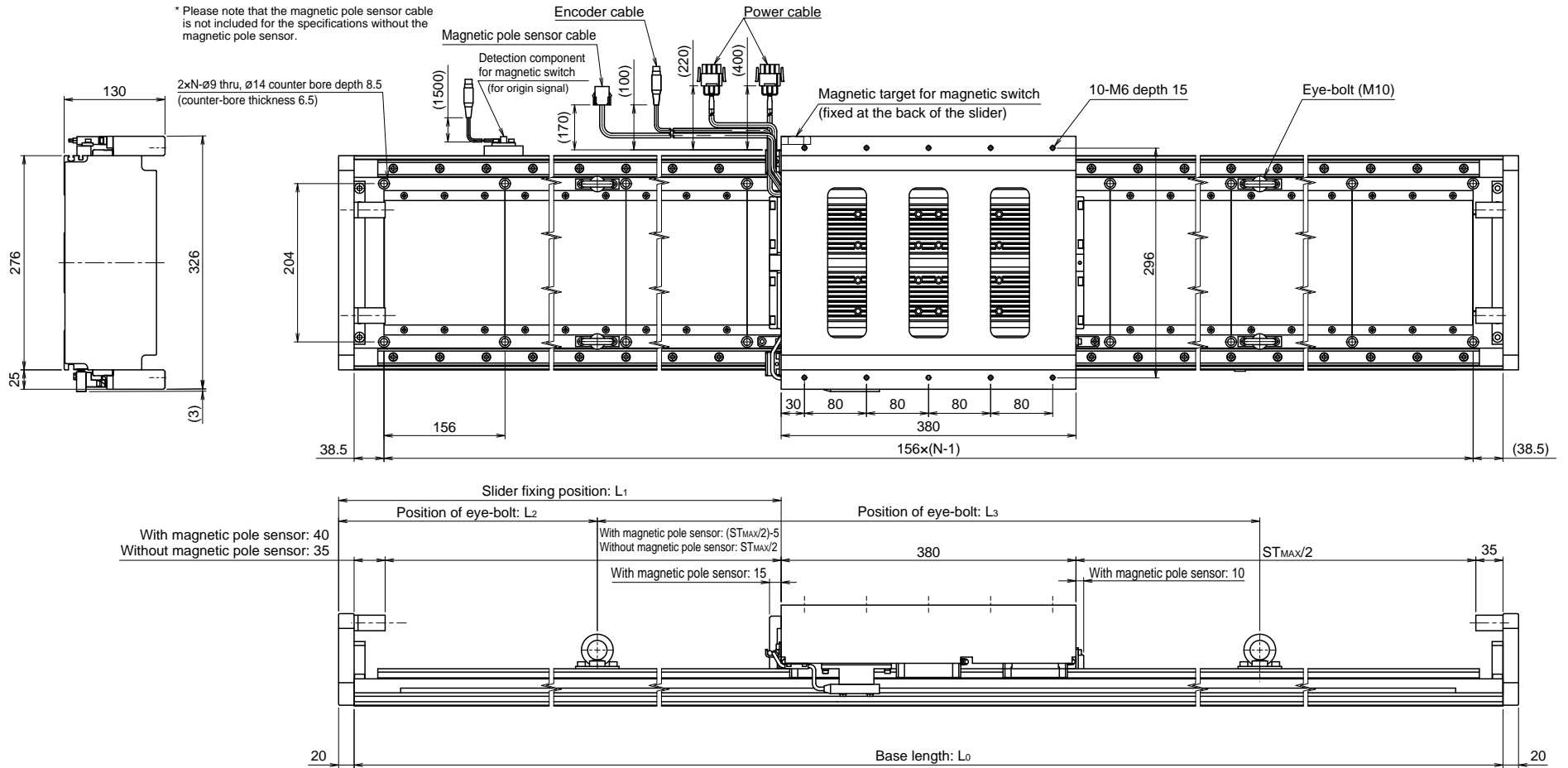

Note: The above diagram is for the specifications with the magnetic pole sensor. Stopper length and stroke between the mechanical stoppers will differ for the specifications without the magnetic pole sensor. Also, please note that the magnetic pole sensor cable is not included.

Base length: $L_0$ [mm]	No. of mounting holes per row: N	Slider fixing position $L_1$ [mm]	Position of eye-bolt $L_2$ [mm]	Position of eye-bolt $L_3$ [mm]
857	6	258.5	180.5	536
1013	7	336.5	222.5	608
1169	8	414.5	267.5	674
1325	9	492.5	300	765
1481	10	570.5	333.5	854
1637	11	648.5	366.5	944
1793	12	726.5	404	1025
1949	13	804.5	432.5	1124

Base length: $L_0$ [mm]	No. of mounting holes per row: N	Slider fixing position $L_1$ [mm]	Position of eye-bolt $L_2$ [mm]	Position of eye-bolt $L_3$ [mm]
2105	14	882.5	465.5	1214
2261	15	960.5	493	1315
2417	16	1038.5	531.5	1394
2573	17	1116.5	564.5	1484
2729	18	1194.5	597.5	1574
2885	19	1272.5	630.5	1664
3041	20	1350.5	675	1731

# Sensor/Cable Carrier Dimensions

## Proximity sensor

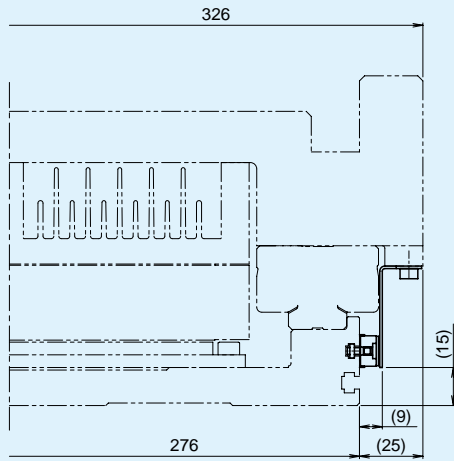

GL-12F [N.O. contact] (3pcs.) (SUNX)

GXL-N12F [N.O. contact] (1pc.) (SUNX)

GXL-N12FB [N.C. contact] (2pcs.) (SUNX)

## Photo sensor

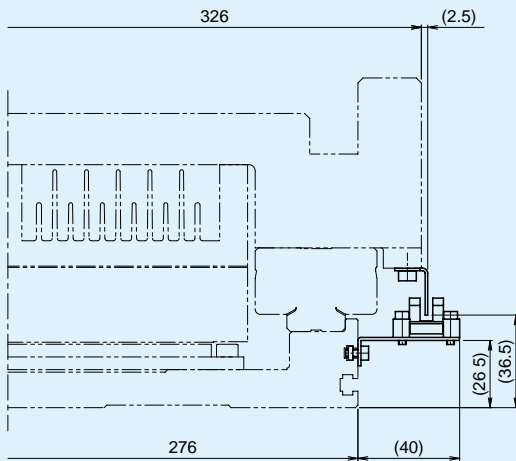

EE-SX671 + EE-1001  
 [Interchangeable for both N.O. and N.C. contact]  
 (3pcs.) (OMRON)

## Standard cable carrier Q

E6.29.040.055.0 (IGUS)

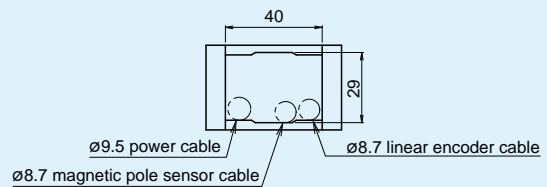
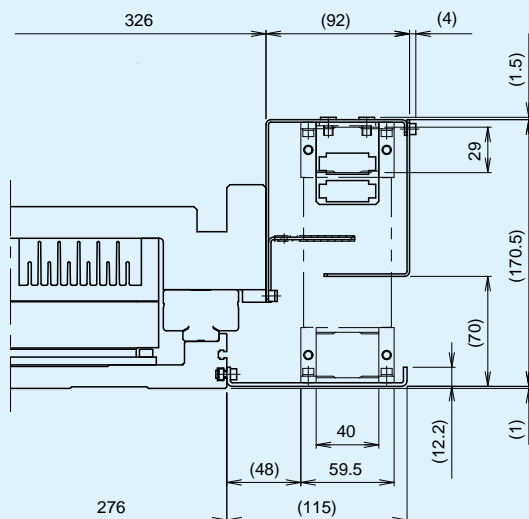

Cross section of the cable carrier

# Driver Model TD

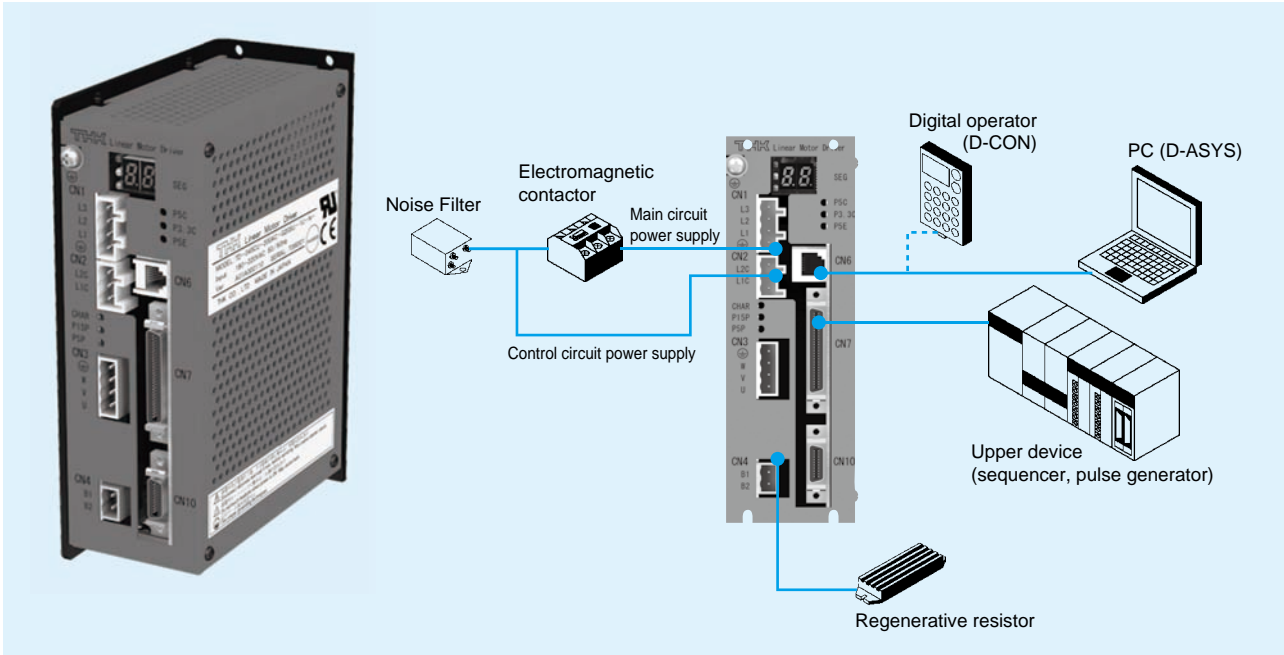

## Driver specifications

Driver model no. TD-		010CU-100AC	020CU-100AC	045CU-100AC	075CU-100AC	010CU-200AC	020CU-200AC	045CU-200AC	075CU-200AC	100CU-200AC	150CU-200AC	300CU-200AC
Motor type	GLM10	S, M	-	-	-	S, M	-	-	-	-	-	-
	GLM15	S	M	-	-	S	M	-	-	-	-	-
	GLM20	-	-	S	M	-	-	S	M	L	-	-
	GLM25	-	-	-	-	-	-	-	-	-	S	M
Main circuit power supply	Voltage/frequency	Single-phase 90 to 120VAC ± 10% 50/60Hz				Single-phase/three-phase 170 to 250VAC 50/60Hz				Three-phase 170 to 250VAC 50/60Hz		
Control circuit power supply	Voltage/frequency	Single-phase 90 to 120VAC ± 10% 50/60Hz				Single-phase 170 to 250VAC 50/60Hz						
Power capacity [kVA]		0.2	0.3	0.7	0.9	0.4	0.75	1.4	1.9	2.3	3.2	6.4 (3x2)
Control specifications	Control method	Single-phase or three-phase full-wave rectification, IGBT PWM control, sinusoidal-wave drive										
	Feedback	90-degree phase difference 2-phase pulse (phase A + phase B)										
Command input pulse	Type	Select either of Code + Pulse train, CCW + CW pulse train or 90-degree phase difference 2 phase pulse (phase A + phase B)										
	Form	Line driver (+5V level)										
	Frequency	Maximum 5Mpps										
LED display		Charged LED, internal power source LED × 5, 7 segments LED 2-digit, display LED × 3										
I/O signals	Position signal output	Phase A, phase B, phase Z: Line driver output										
	Sequence input	Photo coupler input: servo on, forward rotation drive prohibition, reverse rotation drive prohibition, alarm reset, command pulse block, DB input, universal input ×2										
	Sequence output	Photo coupler output: servo alarm, alarm code (3-bit), positioning completion, servo ready, universal output ×2										
Service environment	Service (storage) temperature	0°C to +50°C [-20°C to +85°C] (no freezing allowed)										
	Service (storage) humidity	Max. 90%RH No condensation allowed										
	Anti vibration/impact resistance	2G (JIS C60068-2-6) /100G (JIS C60068-2-27)										
	Line noise tolerance	1500V 500ns Common mode, normal mode										
	Communication functions	RS-232C×1 port: For PC communication software or digital operator connection. I/O status display, parameter setting, alarm display, and JOG motion are available										
Protection functions		Regeneration overload, IPM module abnormality, motor overcurrent (U, V phases), main circuit overvoltage, main circuit insufficient voltage, motor overload, encoder alarm, system alarm, driver overheat, excessive position error, uncontrolled motion detection (during servo ON), EEPROM error, magnetic pole detection error, electronic thermal alarm, abnormal parameter setting, software limit, excessive zero return time, abnormal motion, unbalanced bus voltage <sup>*1</sup> , unbalanced current (U, V phases) <sup>*1</sup>										
Mass [kg]		1.0	1.0	1.0	1.3	1.0	1.0	1.0	1.3	2.0	2.1	3.9

\*1 TD-300CU only.

## External Dimensions of the Driver

TD-010CU, TD-020CU, TD-045CU

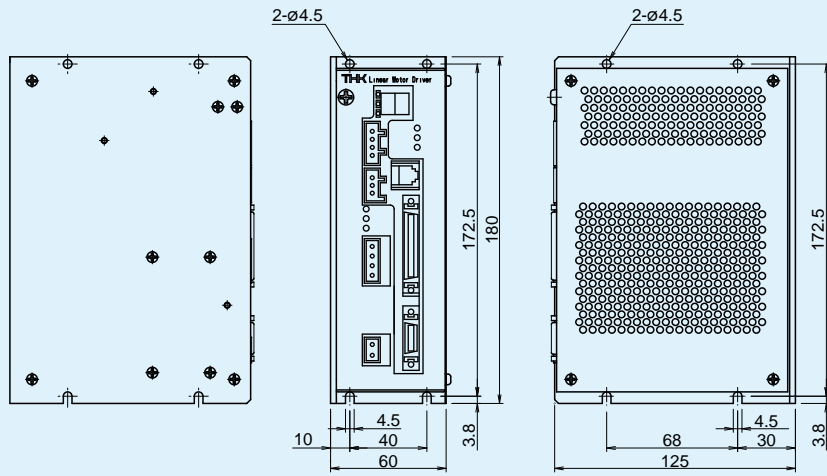

TD-075CU

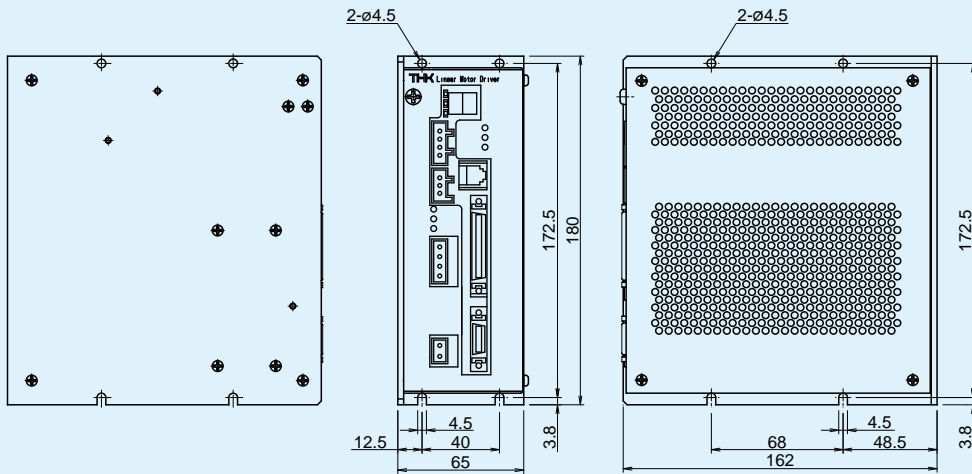

TD-100CU

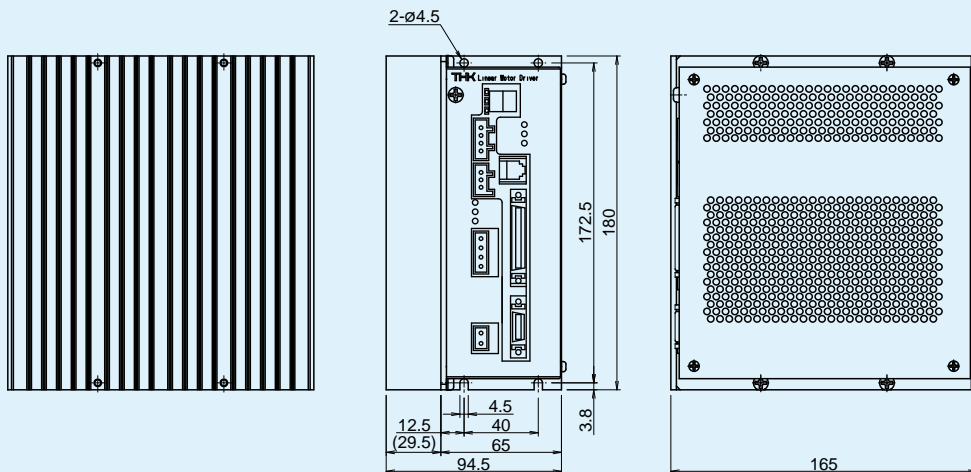

GLM10

GLM15

GLM20

GLM25

Driver Model TD

TD-150CU

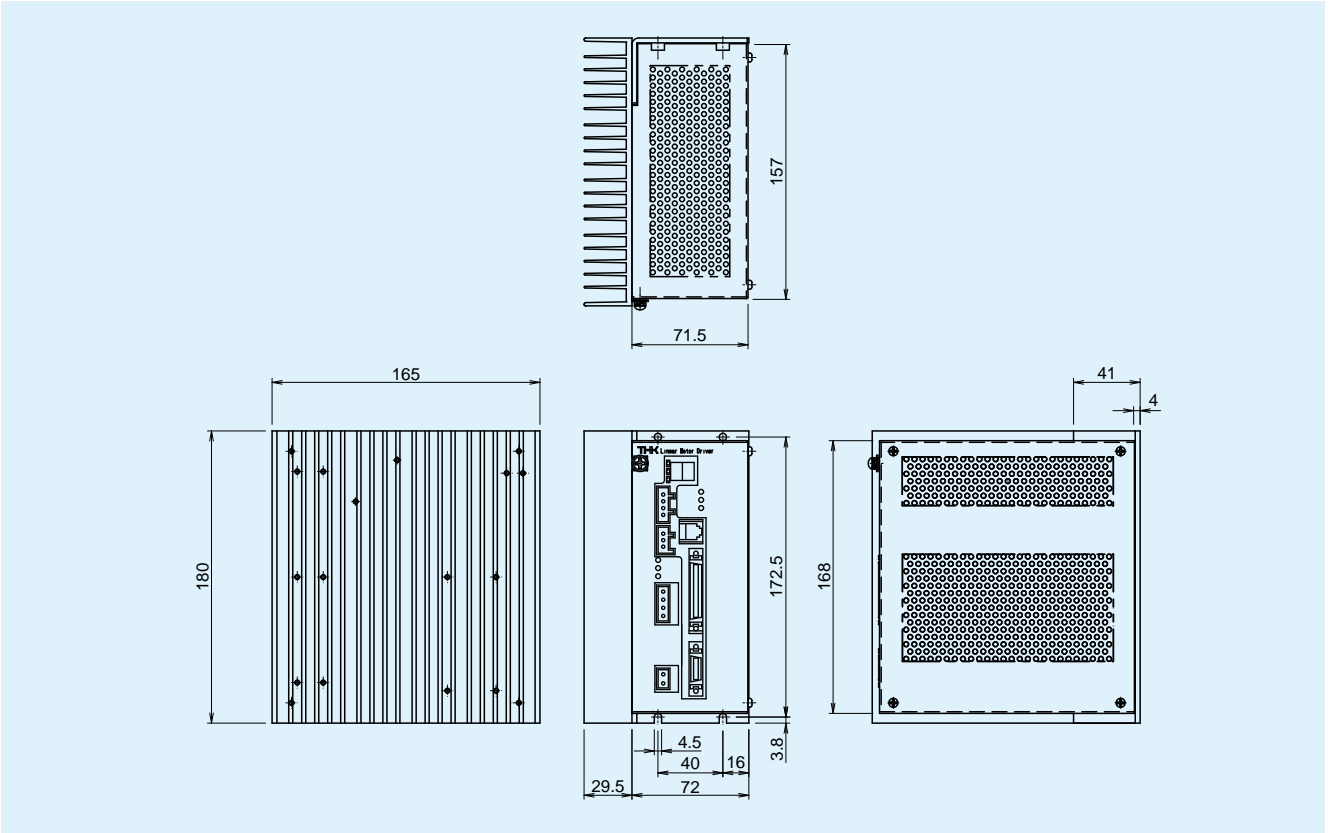

TD-300CU

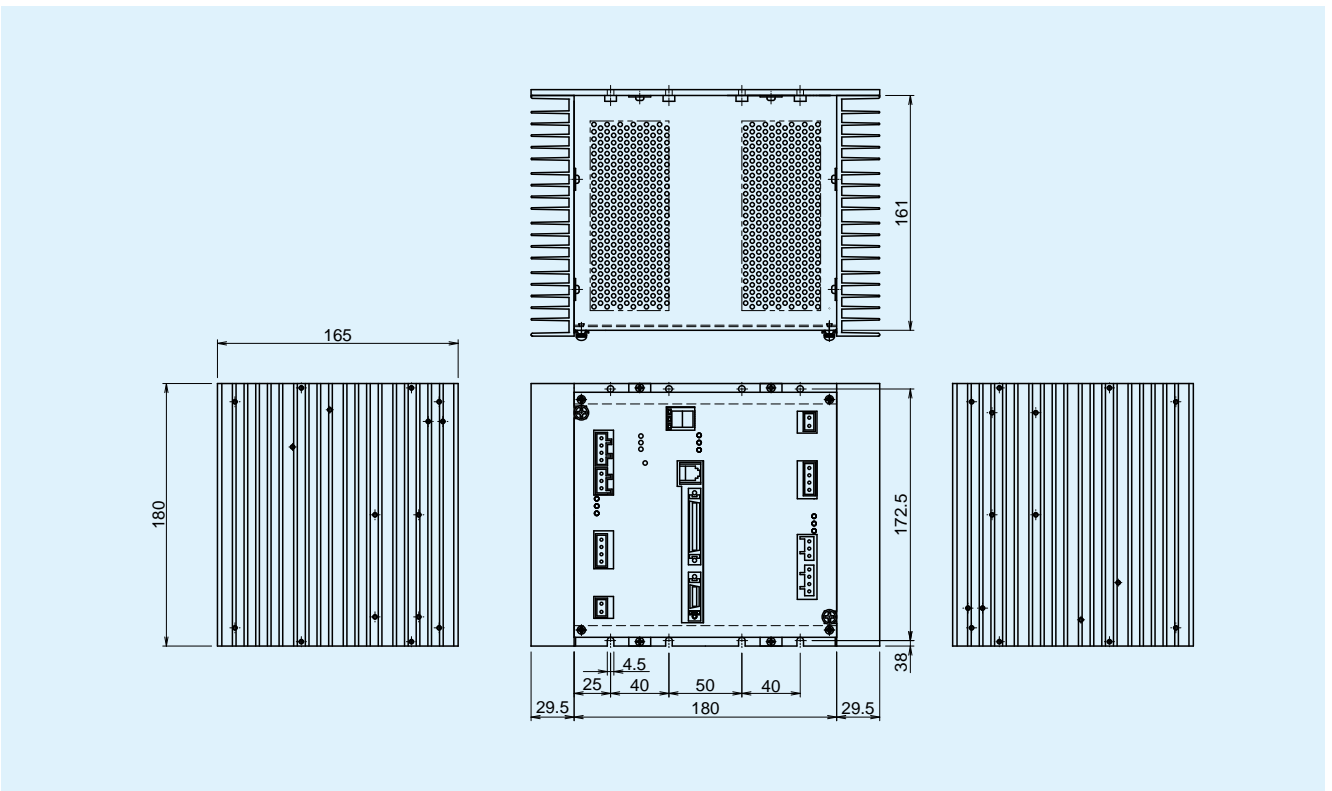

GLM10

GLM15

GLM20

GLM25

Driver Model TD

# External Dimensions of the Interpolator (with the magnetic linear encoder) (Sony Manufacturing Systems)

## MJ100

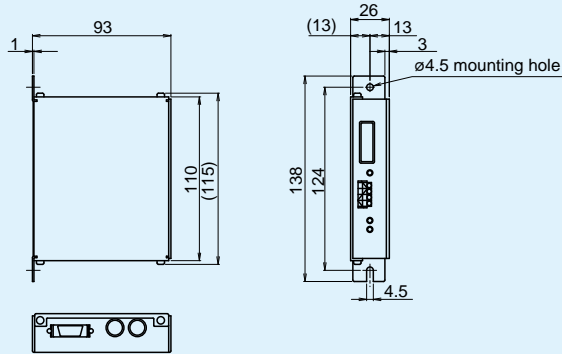

## Cable Specifications

### KDST cable (power cable: for GLM10)

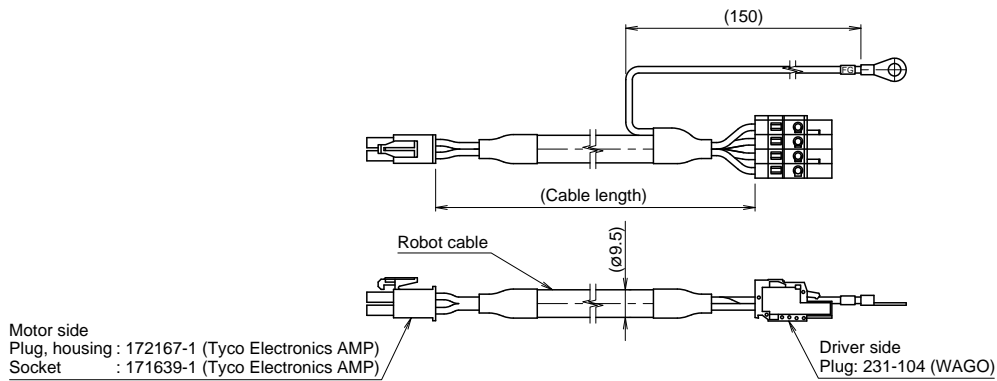

### KDK cable (power cable: for GLM15/25)

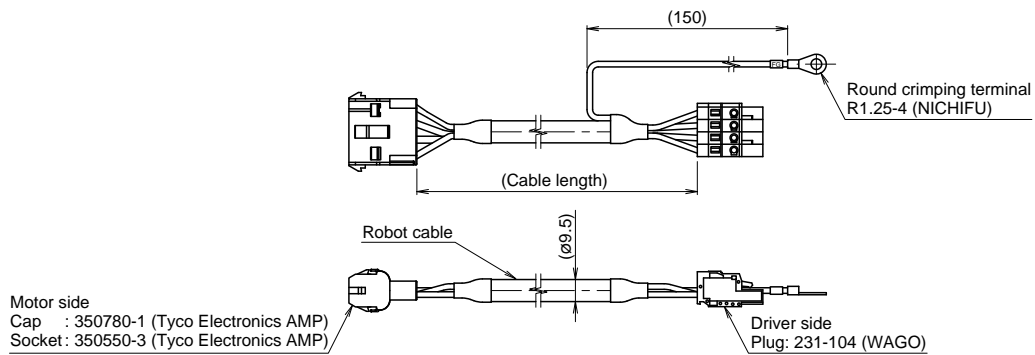

### KDT cable (power cable: for GLM20)

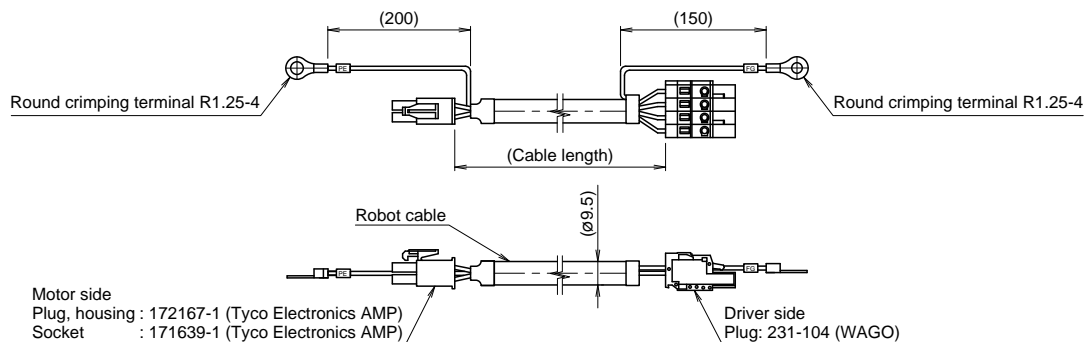

GLM10  
 GLM15  
 GLM20  
 GLM25  
 Driver Model TD

KET cable (cable for the optical linear encoder: for GLM10/15/20/25)

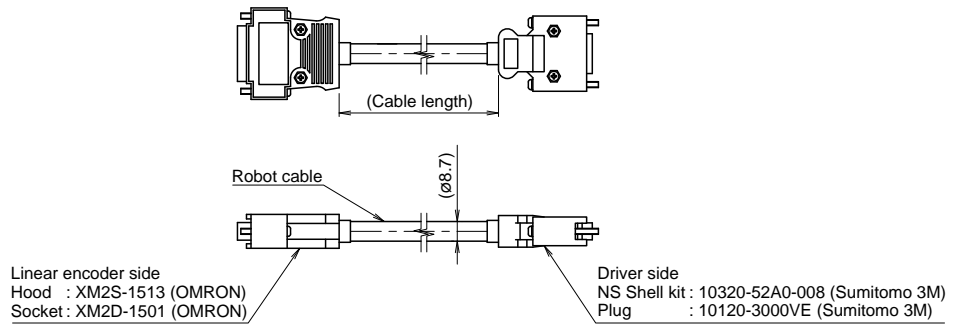

KGET cable (cable for the optical linear encoder/magnetic pole sensor: for GLM10)

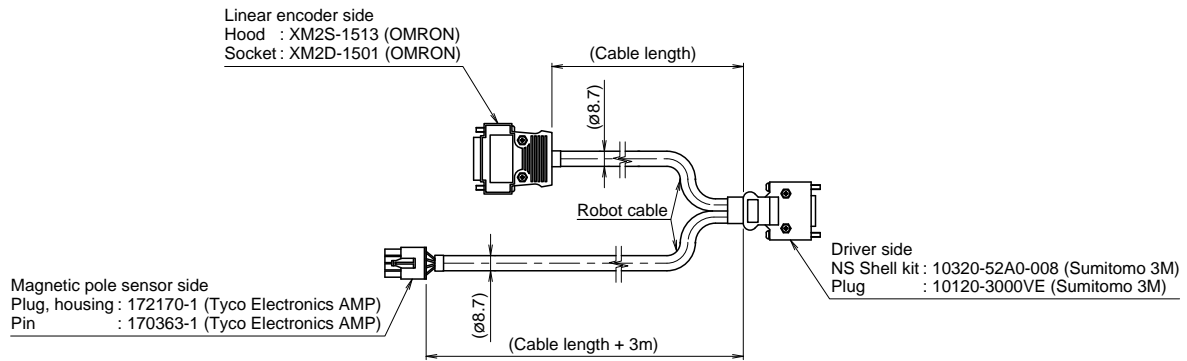

KJET cable (cable for the optical linear encoder/magnetic pole sensor: for GLM15/20/25)

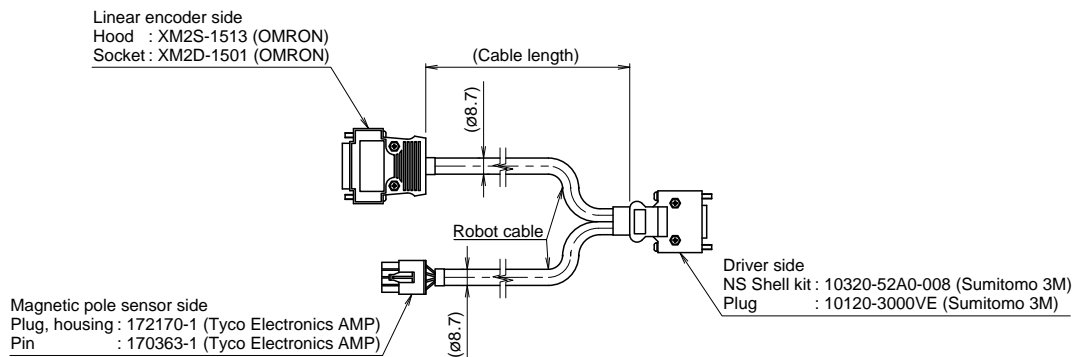

CK cable (cable for the magnetic linear encoder: GLM15/20/25)

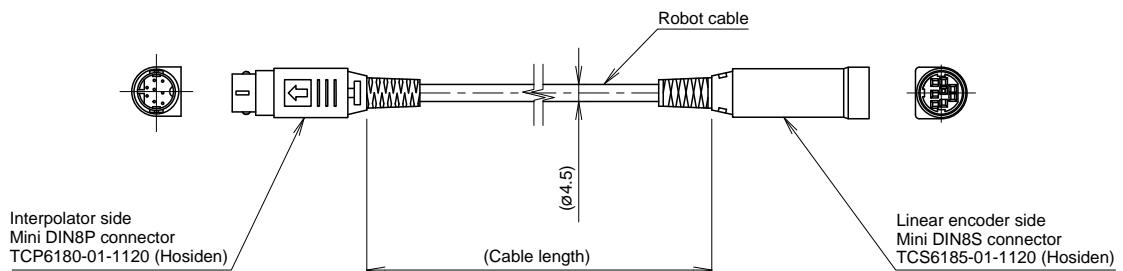

GLM10

GLM15

GLM20

GLM25

Driver Model TD

## KSET cable (connection cable between the interpolator and driver: for GLM15/20/25)

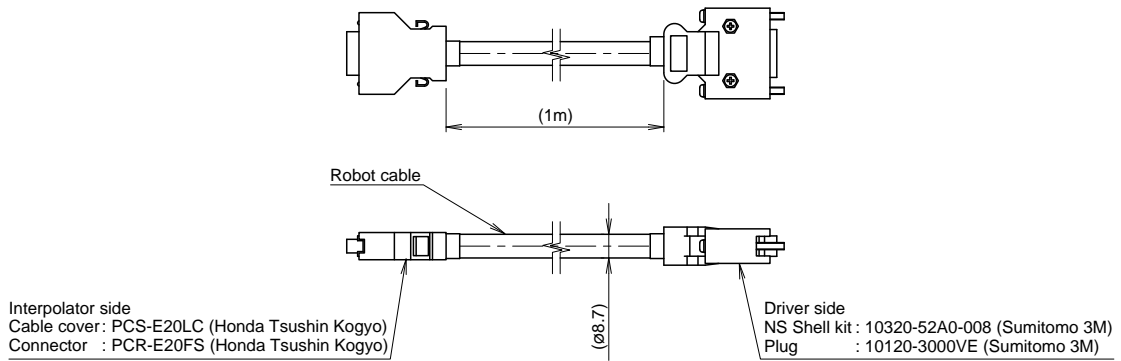

## KSJT cable (connection cable between the interpolator and magnetic pole sensor driver: for GLM15/20/25)

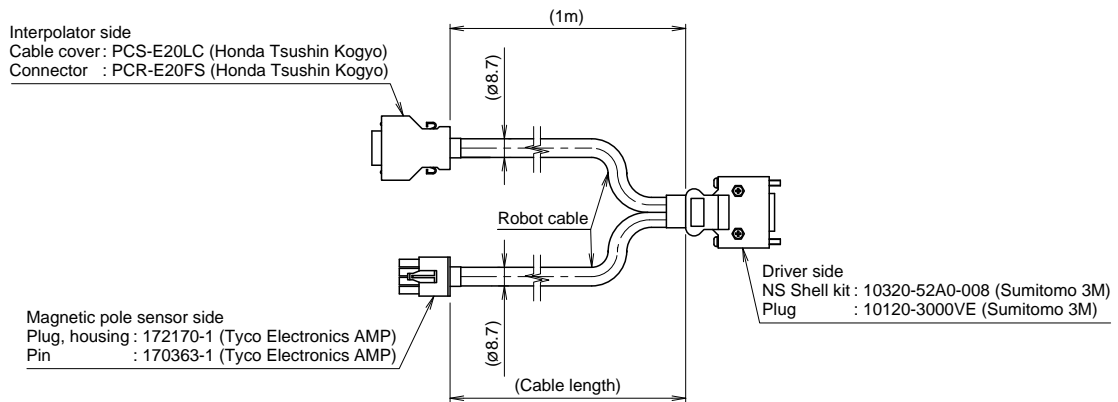

## K232 cable (PC communication cable RS232C)

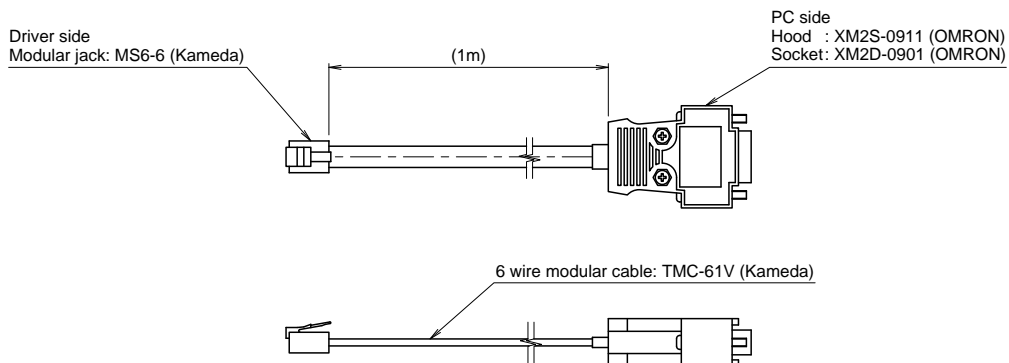

## Nuts for Mounting the Base (for GLM15/20)

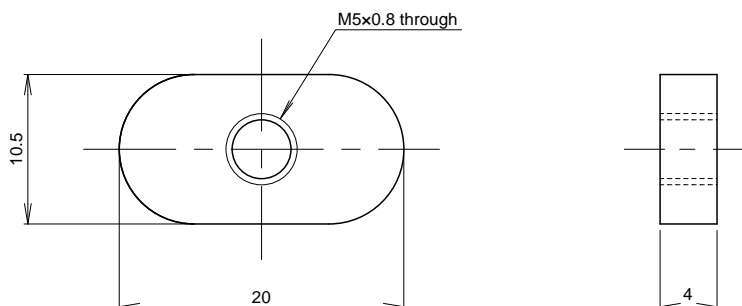

GLM10  
 GLM15  
 GLM20  
 GLM25  
 Driver Model TD

## Selection Method of Model GLM

Select the model GLM following the procedure below.

\* If you provide the usage conditions, THK can select a recommended model number.

- (1) **Evaluate the required maximum thrust** ..... Make sure that the maximum thrust of the motor is bigger than the required thrust for operations. Use with no more than 80% of the maximum thrust of linear motor actuator is recommended when load fluctuations is taken into consideration.
- (2) **Evaluate the RMS thrust** ..... It is recommended to use with 70% or less of the rated continuous thrust by taking load fluctuations into account. If you desire to use it with 70% or more, please contact THK.
- (3) **Confirm the specifications of the selected model number** ..... Check the detailed specifications of the model number selected using the above process, to ensure that external dimensions, stroke, maximum speed, resolution and positioning repeatability all satisfy the requirement.

When confirming your selection, use the values below, and see the following selection example.

GLM10	Motor type: S type		Motor type: M type	
	Driver used	TD-010CU-200AC	TD-010CU-100AC	TD-010CU-200AC
Maximum thrust/Rated continuous thrust [N]	26 / 6		53 / 13	
Motor attraction force [N]	177		353	
Slider weight [kg]	0.6 (0.5)*		0.9 (0.8)*	
Total no. of LM blocks being used [pcs]	4		6	
Sliding resistance of LM block [N/pcs]	1.1			

GLM15	Motor type: S type		Motor type: M type	
	Driver used	TD-010CU-200AC	TD-010CU-100AC	TD-020CU-200AC
Maximum thrust/Rated continuous thrust [N]	150 / 40		279 / 81	
Motor attraction force [N]	330		650	
Slider weight [kg]	3.0 (2.8)*		4.3 (4.1)*	
Total no. of LM blocks being used [pcs]	4		4	
Sliding resistance of LM block [N/pcs]	2.5		3.0	

GLM20	Motor type: S type		Motor type: M type		Motor type: L type
	Driver used	TD-045CU-200AC	TD-045CU-100AC	TD-075CU-200AC	TD-075CU-100AC
Maximum thrust/Rated continuous thrust [N]	333 / 59	285 / 48	612 / 113	481 / 124	933 / 178
Motor attraction force [N]	1440		2592		3744
Slider weight [kg]	5.0 (4.8)*		8.2 (8.0)*		11.4 (11.2)*
Total no. of LM blocks being used [pcs]	4		6		8
Sliding resistance of LM block [N/pcs]	3.7				

GLM25	Motor type: S type	Motor type: M type
	Driver used	TD-150CU-200AC
Maximum thrust/Rated continuous thrust [N]	1557 / 450	3072 / 892
Motor attraction force [N]	3120	6607
Slider weight [kg]	25.3 (25)*	48.3 (48)*
Total no. of LM blocks being used [pcs]	4	6
Sliding resistance of LM block [N/pcs]	5.1	

\* The values in ( ) are for the specifications without the magnetic pole sensor.

Note: Grease is filled with AFJ grease.

The examination below shows that if GLM15 M type (for 200VAC) can drive a payload of 2kg along the following motion profile:

- Selection model : GLM15 M type 200VAC specifications with magnetic pole sensor
- Payload :  $m_1 = 2\text{kg}$
- Slider mass :  $m_2 = 4.3\text{kg}$
- Motion speed :  $V = 1.0\text{m/s}$
- Acceleration :  $\alpha = 10\text{m/s}^2$
- Stroke :  $L = 300\text{mm}$
- Friction coefficient :  $\mu = 0.01$
- Gravitational acceleration :  $g = 9.807\text{m/s}^2$
- Motion profile : Fig.1

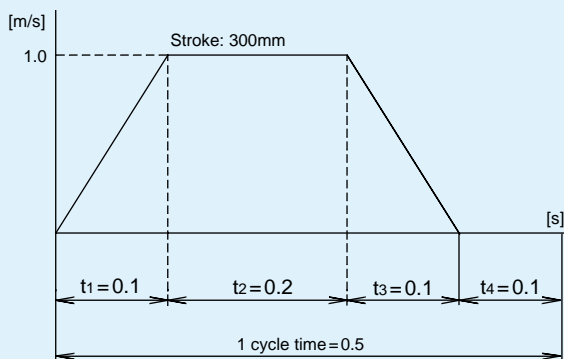

Fig.1 Motion profile

[\* See Page 62 for slider weight]

(1) Evaluating the maximum thrust

The required maximum thrust is the largest value out of the values calculated by the following three formulas:

$$\begin{aligned} \text{Load force} \quad & : F = m_1 \times g \times \mu \\ & = 2 \times 9.807 \times 0.01 \\ & = 0.2[\text{N}] \\ \text{Thrust during acceleration} \quad & : F_a = (m_1 + m_2) \times \alpha + F \\ & = (2 + 4.3) \times 10 + 0.2 \\ & = 63.2[\text{N}] \\ \text{Thrust during deceleration} \quad & : F_d = (m_1 + m_2) \times \alpha - F \\ & = (2 + 4.3) \times 10 - 0.2 \\ & = 62.8[\text{N}] \end{aligned}$$

From the above calculation results:  
Required maximum thrust:  $F_{\max} = F_a = 63.2[\text{N}]$

Thrust-speed characteristics chart (Fig.2) for GLM15 M type shows that the thrust of the motor's maximum thrust:  $F_{\text{peak}}$  (at speed = 1.0m/s) = 271.3[N]

Therefore, the ratio of the required maximum thrust to the motor's maximum thrust is:

$$\frac{F_{\max}}{F_{\text{peak}}} = \frac{63.2}{271.3} = 0.23 = 23\% (<80\%)$$

Motor type : M type  
Driver model no. : TD-020CU-200AC

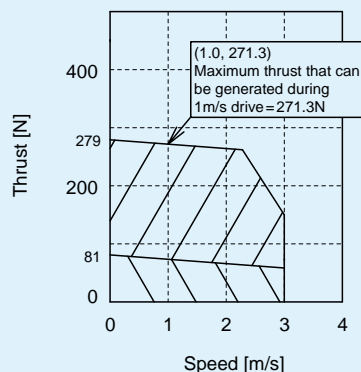

Fig.2 Thrust-speed characteristics chart (Motor attraction force is included)

(2) Evaluating the RMS thrust

Calculate the RMS (root-mean-square) thrust from the load force, thrust during acceleration, and thrust during deceleration with respect to each duration.

RMS (root-mean-square) thrust:

$$F_{rms} = \sqrt{\frac{F_a^2 \times t_1 + F^2 \times (t_2 + t_4) + F_d^2 \times t_3}{T}}$$

$$= \sqrt{\frac{63.2^2 \times 0.1 + 0.2^2 \times (0.2 + 0.1) + 62.8^2 \times 0.1}{0.5}}$$

$$= \underline{\underline{39.8[N]}}$$

Also, from the motion profile, average speed:  $V_{average}$  is calculated:

$$V_{average} = \frac{L}{T \text{ (1 cycle time)}} = \frac{300}{0.5} = 600\text{mm/s} = 0.6\text{m/s}$$

Thrust-speed characteristics chart (Fig.4) for GLM15 M type shows that the thrust of the motor's rated continuous thrust:

$$F_{cont.} \text{ (at the time of average speed } 0.6\text{m/s)} = \underline{\underline{76.4[N]}}$$

Therefore, the RMS thrust ratio for the rated continuous thrust is:

$$\frac{F_{rms}}{F_{cont.}} = \frac{39.8}{76.4} = 0.52 = \underline{\underline{52\%}} (<70\%)$$

As the result above, of the maximum thrust ratio and RMS thrust ratio, this application shall be concluded operative.

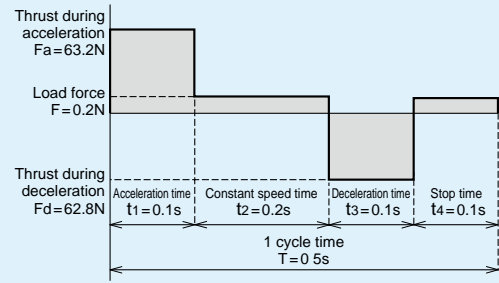

Fig.3 Thrust and time

Motor type : M type  
Driver model no. : TD-020CU-200AC

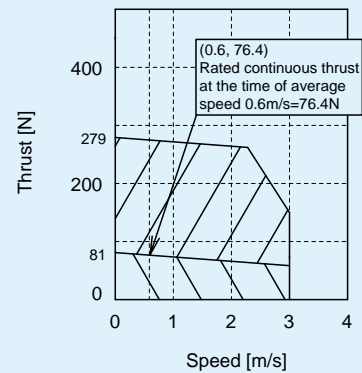

Fig.4 Thrust-speed characteristics chart (Motor attraction force is included)

## Precautions on Use

### ● Environment

The wrong environment can cause failure for the actuator and driver. The best places to use the device are as follows:

- For actuators, an environment with a room and ambient temperature from 0 to 40 °C and humidity of no more than 80% RH that will not expose the product to freezing or condensation.
- For drivers, an environment with a room and ambient temperature from 0 to 50 °C and humidity of no more than 90% RH that will not expose the product to freezing or condensation.
- A place free from corrosive gas or flammable gas.
- Places where none of the following are flying around: iron particles, or any other conductive particles, dust, oil mist, cutting fluid, water, salt, organic solvents.
- Places that are not exposed to direct sunlight or radiant heat.
- Places where no strong electric fields or strong magnetic fields occur.
- Places where vibration or impact are not transmitted to the unit.
- Places that are easy to inspect and clean.

### ● Safety Precautions

- Do not drop or knock this product. Doing so may cause injury or damage the unit.
- Unnecessarily disassembling this product may allow foreign objects to enter and reduce functionality. Also, there is a risk of electric shock from the driver.
- The PL seal is attached to the end plate of the unit body. If the user has selected a unit option without an end plate, no PL seal will be attached. Therefore, the user must prepare his own PL seal.
- The magnet plate (stator) is a very powerful magnet. Keep magnetic bodies (particularly metals) away from the magnet plate. There is a risk of getting the finger(s) jammed between the metal body and the magnet due to the attractive force of the magnet. Also, persons using cardiac pacemakers should absolutely stay away from the magnet.
- Never touch the moving section of the actuator when it is energized. Also, when the product is in motion, or in a state of readiness for motion, do not enter the movement zone of the actuator.
- When carrying out installation, adjustment, inspection or maintenance of the actuator unit, driver or connected associated devices, always remove all plugs from the power sockets, and use locking or safety plugs etc. so that no one but an operator can turn on the power again. Also, display a notice explaining what work is in progress in a position that is readily seen.
- If two or more people are involved in the operation, confirm the procedures such as sequences, signs, and abnormalities in advance, and appoint another person for monitoring the operation.
- Read the manual carefully, understanding the content properly, and be sure to observe all safety precautions.

- "LM GUIDE," "Caged Ball," and " " are registered trademarks of THK CO., LTD.
- The actual products may differ from the pictures and photographs in this catalog.
- Outward appearances and specifications is subject to change without notification for purposes of improvement, please inquire before using them.
- Although great care has been taken in the production of this catalog, THK will not take any responsibility for damage resulting from typographical errors or omissions.
- In exporting our products and technology, or selling them for the purpose of export, THK has a basic policy of observing laws relating to foreign exchange, trade and other laws. For export of THK products as single items, contact THK in advance.

All rights reserved

# THK CO., LTD.

HEAD OFFICE 3-11-6, NISHI-GOTANDA, SHINAGAWA-KU, TOKYO 141-8503 JAPAN  
 INTERNATIONAL SALES DEPARTMENT PHONE:+81-3-5434-0351 FAX:+81-3-5434-0353  
 Global site : <http://www.thk.com/>

### NORTH AMERICA

- THK America, Inc.  
 ● HEADQUARTERS  
 Phone:+1-847-310-1111 Fax:+1-847-310-1271  
 ● CHICAGO OFFICE  
 Phone:+1-847-310-1111 Fax:+1-847-310-1182  
 ● NORTH EAST OFFICE  
 Phone:+1-845-369-4035 Fax:+1-845-369-4909  
 ● ATLANTA OFFICE  
 Phone:+1-770-840-7990 Fax:+1-770-840-7897  
 ● LOS ANGELES OFFICE  
 Phone:+1-949-955-3145 Fax:+1-949-955-3149  
 ● SAN FRANCISCO OFFICE  
 Phone:+1-925-455-8948 Fax:+1-925-455-8965  
 ● DETROIT OFFICE  
 Phone:+1-248-858-9330 Fax:+1-248-858-9455  
 ● TORONTO OFFICE  
 Phone:+1-905-820-7800 Fax:+1-905-820-7811

### SOUTH AMERICA

THK Brasil LTDA  
 Phone:+55-11-3767-0100 Fax:+55-11-3767-0101

### EUROPE

- THK GmbH  
 ● EUROPEAN HEADQUARTERS  
 Phone:+49-2102-7425-0 Fax:+49-2102-7425-217  
 ● DÜSSELDORF OFFICE  
 Phone:+49-2102-7425-0 Fax:+49-2102-7425-299

### ● FRANKFURT OFFICE

- Phone:+49-2102-7425-650 Fax:+49-2102-7425-699  
 ● STUTTGART OFFICE  
 Phone:+49-7150-9199-0 Fax:+49-7150-9199-888  
 ● MÜNCHEN OFFICE  
 Phone:+49-8937-0616-0 Fax:+49-8937-0616-26  
 ● U.K. OFFICE  
 Phone:+44-1908-30-3050 Fax:+44-1908-30-3070  
 ● ITALY MILANO OFFICE  
 Phone:+39-039-284-2079 Fax:+39-039-284-2527  
 ● ITALY BOLOGNA OFFICE  
 Phone:+39-051-641-2211 Fax:+39-051-641-2230  
 ● SWEDEN OFFICE  
 Phone:+46-8-445-7630 Fax:+46-8-445-7639  
 ● AUSTRIA OFFICE  
 Phone:+43-7229-51400 Fax:+43-7229-51400-79  
 ● SPAIN OFFICE  
 Phone:+34-93-652-5740 Fax:+34-93-652-5746  
 ● TURKEY OFFICE  
 Phone:+90-216-362-4050 Fax:+90-216-569-7150  
 ● PRAGUE OFFICE  
 Phone:+420-2-41025-100 Fax:+420-2-41025-199  
 THK Europe B.V.  
 ● EINDHOVEN OFFICE  
 Phone:+31-040-290-9500 Fax:+31-040-290-9599  
 THK France S.A.S.  
 Phone:+33-4-3749-1400 Fax:+33-4-3749-1401

### CHINA

- THK (CHINA) CO.,LTD.  
 ● HEADQUARTERS  
 Phone:+86-411-8733-7111 Fax:+86-411-8733-7000  
 ● SHANGHAI OFFICE  
 Phone:+86-21-6219-3000 Fax:+86-21-6219-9890  
 ● BEIJING OFFICE  
 Phone:+86-10-8441-7277 Fax:+86-10-6590-3557  
 ● CHENGDU OFFICE  
 Phone:+86-28-8526-8025 Fax:+86-28-8525-6357  
 ● GUANGZHOU OFFICE  
 Phone:+86-20-8523-8418 Fax:+86-20-3801-0456  
 THK (SHANGHAI) CO.,LTD.  
 Phone:+86-21-6275-5280 Fax:+86-21-6219-9890

### TAIWAN

- THK TAIWAN CO.,LTD.  
 ● TAIPEI HEAD OFFICE  
 Phone:+886-2-2888-3818 Fax:+886-2-2888-3819  
 ● TAICHUNG OFFICE  
 Phone:+886-4-2359-1505 Fax:+886-4-2359-1506  
 ● TAINAN OFFICE  
 Phone:+886-6-289-7668 Fax:+886-6-289-7669

### KOREA

- SEOUL REPRESENTATIVE OFFICE  
 Phone:+82-2-3468-4351 Fax:+82-2-3468-4353

### SINGAPORE

- THK LM SYSTEM Pte. Ltd.  
 Phone:+65-6884-5500 Fax:+65-6884-5550

### INDIA

- BANGALORE REPRESENTATIVE OFFICE  
 Phone:+91-80-2330-1524 Fax:+91-80-2314-8226