

SSR

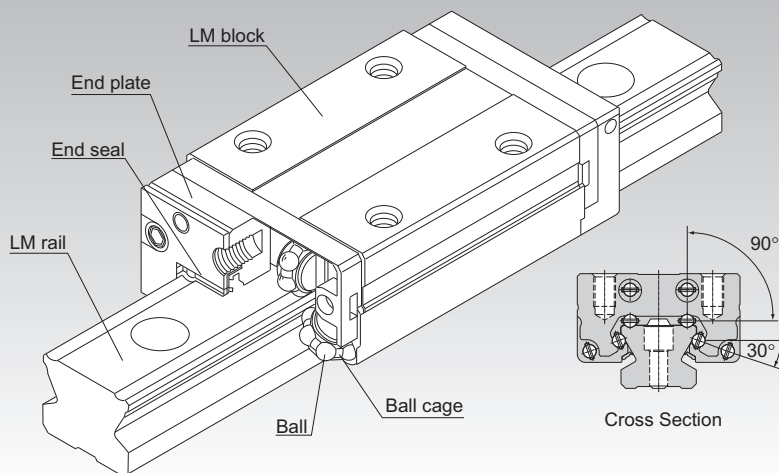

Radial Type Caged Ball LM Guide Model SSR



Note: For the ball cage, see **A1-90**.

Selection Criteria **A1-10**

Design Highlights **A1-482**

Options **A1-507**

Model No. **A1-577**

Handling Precautions **A1-583**

Accessories for Lubrication **A24-1**

Mounting Procedure **B1-89**

Equivalent Moment Factor **A1-43**

Rated Loads in All Directions **A1-61**

Equivalent Factor in Each Direction **A1-63**

Radial Clearance **A1-73**

Accuracy Standards **A1-79**

Shoulder Height of the Mounting Base and the Corner Radius **A1-495**

Reference Error Tolerance for the Mounting Surface **A1-498**

Dimensions of Each Model with Options Attached **A1-521**

Structure and Features

Balls roll in four rows of raceways precision-ground on the LM rail and LM block and are circulated by ball cages and end plates incorporated in the LM block.

Use of the ball cage eliminates friction between balls and increases grease retention, thereby achieving low noise, high speeds, and long-term maintenance-free operations.

Compact, Radial Type

Since it is a compactly designed model with a low cross-sectional height and a ball contact structure that is suited to large loads in the radial direction, this model is optimal for horizontal guide units.

Superb Planar Running Accuracy

Use of a ball contact structure that is suited to large loads in the radial direction minimizes radial displacement under radial loads and allows stable, highly accurate motion.

Self-Adjustment Capability

The self-adjustment capability of the front-to-front configuration of THK's unique circular-arc grooves (DF set) enables mounting error to be absorbed even under a preload, thus achieving highly accurate, smooth linear motion.

Stainless Steel Type Also Available

A special type whose LM block, LM rail, and balls are made of stainless steel is also available.

Types and Features

Model SSR-XW

With this type, the LM block has a smaller width (W) and tapped holes. It is used in places where the space for the table width is limited.

Dimensional Table → [A1-110](#)

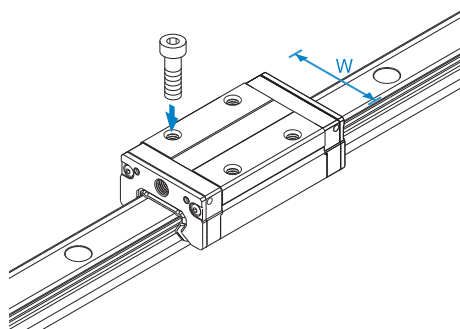

Model SSR-XV

This type has the same cross-sectional shape as SSR-XW but has a shorter overall LM block length (L).

Dimensional Table → [A1-112](#)

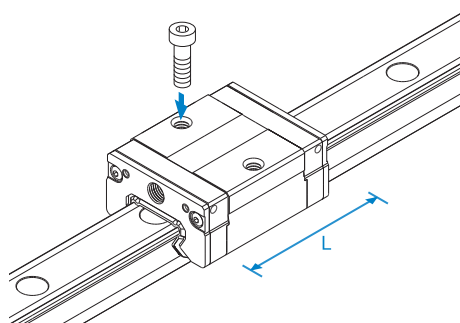

Model SSR-XTB

The flange of the LM block has through holes. It is used in places where the table cannot have through holes for mounting bolts.

Dimensional Table → [A1-114](#)

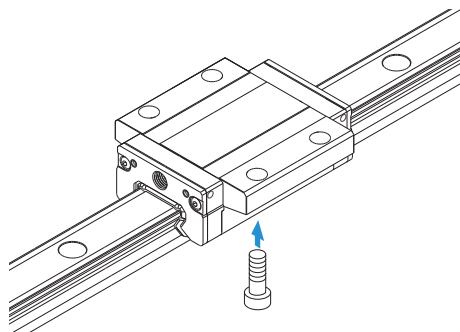

Model SSR-XSB

This type has the same cross-sectional shape as SSR-XTB but has a shorter overall LM block length (L).

Dimensional Table⇒ **A1-116**

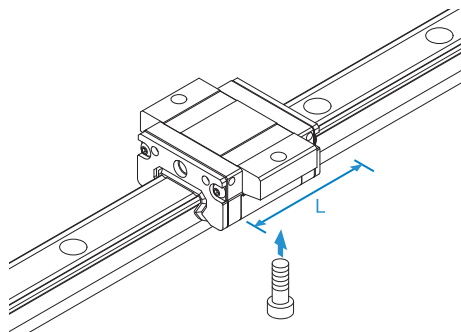

LM Guide

Models SSR-XW and SSR-XWM

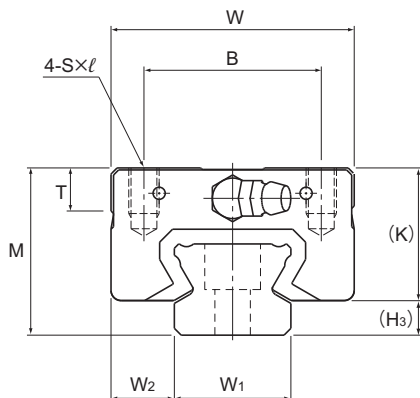

Model No.	Outer dimensions			LM block dimensions										Pilot hole for side nipple			H ₃
	Height	Width	Length ¹	B	C	S × l	L ₁	T	K	N	E	Grease nipple	e ₀	f ₀	D ₀ ²		
	M	W	L														
SSR 15XW SSR 15XWM	24	34	56.9	26	26	M4 × 7	39.9	6.5	19.5	4.5	5.5	PB1021B	4.5	2.7	3	4.5	
SSR 20XW SSR 20XWM	28	42	66.5	32	32	M5 × 8	46.6	8.2	22	5.5	12	B-M6F	5.2	2.9	3	6	
SSR 25XW SSR 25XWM	33	48	83	35	35	M6 × 9	59.8	8.4	26.2	6	12	B-M6F	6.8	3.3	3	6.8	
SSR 30XW SSR 30XWM	42	60	97	40	40	M8 × 12	70.7	11.3	32.5	8	12	B-M6F	7.6	4.5	4	9.5	
SSR 35XW	48	70	110.9	50	50	M8 × 12	80.5	13	36.5	8.5	12	B-M6F	8.8	4.7	4	11.5	

Model number coding

SSR25X W 2 QZ UU C1 M +1240L Y P T M - II

Model number

Type of LM block

No. of LM blocks used on the same rail

With QZ lubricator

Contamination protection accessory symbol

Stainless steel LM block

Radial clearance symbol
Normal (No symbol)
Light preload (C1)

LM rail length (in mm)

Applied to only 15 and 25

Accuracy symbol
Normal grade (No Symbol)
High accuracy grade (H)/Precision grade (P)
Super precision grade (SP)/Ultra precision grade (UP)

Stainless steel LM rail

Symbol for LM rail jointed use

Symbol for No. of rails used on the same plane

Notes: This model number indicates that a single-rail unit constitutes one set (i.e., required number of sets when 2 rails are used in parallel is 2 at a minimum).

Grease nipples are not installed when there is a QZ Lubricator. Contact THK if you want to use a grease nipple for a model with a QZ.

See **A1-547** for contamination protection accessories, see **A1-73** for radial clearance symbol. See **A1-79** for accuracy symbol. See **A1-13** for symbol for number of rails used on the same plane.

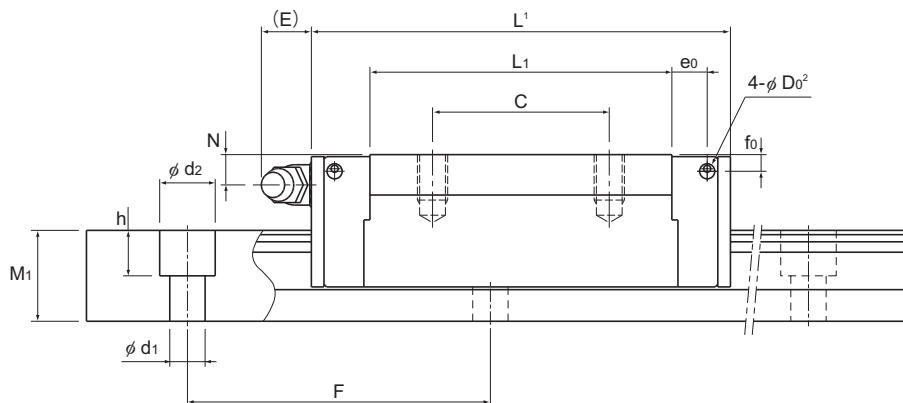

Unit: mm

LM rail dimensions						Basic load rating ¹		Static permissible moment kN·m ⁵					Mass	
Width W ₁ ±0.05	W ₂	Height M ₁	Pitch F	Length ³ d ₁ × d ₂ × h	Length ³ Max	C kN	C ₀ kN	M _A		M _B		M _C	LM block kg	LM rail kg/m
								1 block	2 blocks	1 block	2 blocks	1 block		
15	9.5	12.5	60	4.5 × 7.5 × 5.3	3000 (1240)	14.7	16.5	0.0792	0.44	0.0486	0.274	0.0962	0.15	1.2
20	11	15.5	60	6 × 9.5 × 8.5	3000 (1480)	19.6	23.4	0.138	0.723	0.0847	0.448	0.18	0.25	2.1
23	12.5	18	60	7 × 11 × 9	3000 (2020)	31.5	36.4	0.258	1.42	0.158	0.884	0.33	0.4	2.7
28	16	23	80	7 × 11 × 9	3000 (2520)	46.5	52.7	0.446	2.4	0.274	1.49	0.571	0.8	4.3
34	18	27.5	80	9 × 14 × 12	3000	64.6	71.6	0.711	3.72	0.437	2.31	0.936	1.1	6.4

¹ Length L shown in the table is the length with the contamination protection accessories, code UU or SS.

If other contamination protection accessories or lubricant equipment are installed, the total block length will increase. (See **A1-521** or **A1-543**)

² D₀ are the pilot holes for when a grease nipple is desired for a product with LaCS or a QZ Lubricator.

Pilot holes are not drilled through for models other than those stated above.

For grease nipple mount machining, contact THK.

³ The maximum length indicates the standard maximum length of an LM rail. (See **A1-118**.)

⁴ The basic load rating is for a load in the radial direction.

Use **A1-61** on Table 7 to calculate the load rating for loads in the reverse-radial direction or lateral direction.

⁵ Static permissible moment 1 block: the static permissible moment with one LM block

2 blocks: the static permissible moment with two LM blocks in close contact with each other

Notes: The M in the model number symbol indicates that the LM block, LM rail and balls are made of stainless steel.

The stainless steel provides excellent corrosion resistance and environmental resistance.

For models SSR15 and 25, two types of rails with different mounting hole dimensions are available. (See Table 1.)

When replacing this model with model SR, pay attention to the mounting hole dimension of the LM rail. Contact THK for details.

Table 1: Rail Mounting Hole Dimensions

Model No.	Standard rail	Semi-standard rail
SSR 15	For M4 (symbol Y)	For M3 (no symbol)
SSR 25	For M6 (symbol Y)	For M5 (no symbol)

Models SSR-XV and SSR-XVM

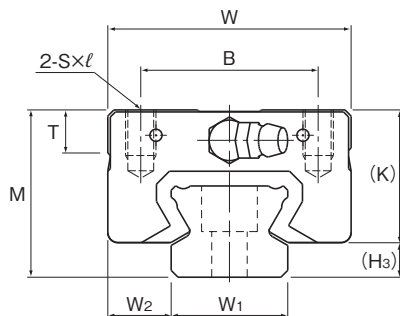

Model No.	Outer dimensions			LM block dimensions								Pilot hole for side nipple			H ₃
	Height	Width	Length ¹	B	S×ℓ	L ₁	T	K	N	E	Grease nipple	e ₀	f ₀	D ₀ ²	
	M	W	L												
SSR 15XV SSR 15XVM	24	34	40.3	26	M4×7	23.3	6.5	19.5	4.5	5.5	PB1021B	4.5	2.7	3	4.5
SSR 20XV SSR 20XVM	28	42	47.7	32	M5×8	27.8	8.2	22	5.5	12	B-M6F	5.2	2.9	3	6
SSR 25XV SSR 25XVM	33	48	60	35	M6×9	36.8	8.4	26.2	6	12	B-M6F	6.8	3.3	3	6.8
SSR 30XV SSR 30XVM	42	60	66.7	40	M8×12	40.4	11.5	32.5	8	12	B-M6F	7.6	4.5	4	9.5
SSR 35XV	48	70	77.5	50	M8×12	47.1	16.2	36.5	8.5	12	B-M6F	8.8	4.7	4	11.5

Model number coding

SSR25X V 2 QZ UU C1 M +1240L Y P T M -III

Model number

Type of LM block

No. of LM blocks used on the same rail

With QZ lubricator

Contamination protection accessory symbol

Radial clearance symbol
Normal (No symbol)
Light preload (C1)

Stainless steel LM block

LM rail length (in mm)

Applied to only 15 and 25

Accuracy symbol
Normal grade (No Symbol)
High accuracy grade (H)/Precision grade (P)
Super precision grade (SP)/Ultra precision grade (UP)

Stainless steel LM rail

Symbol for LM rail jointed use

Symbol for No. of rails used on the same plane

Notes: This model number indicates that a single-rail unit constitutes one set (i.e., required number of sets when 3 rails are used in parallel is 3 at a minimum).

Grease nipples are not installed when there is a QZ Lubricator. Contact THK if you want to use a grease nipple for a model with a QZ. See **A1-547** for contamination protection accessories, see **A1-73** for radial clearance symbol. See **A1-79** for accuracy symbol. See **A1-13** for symbol for number of rails used on the same plane.

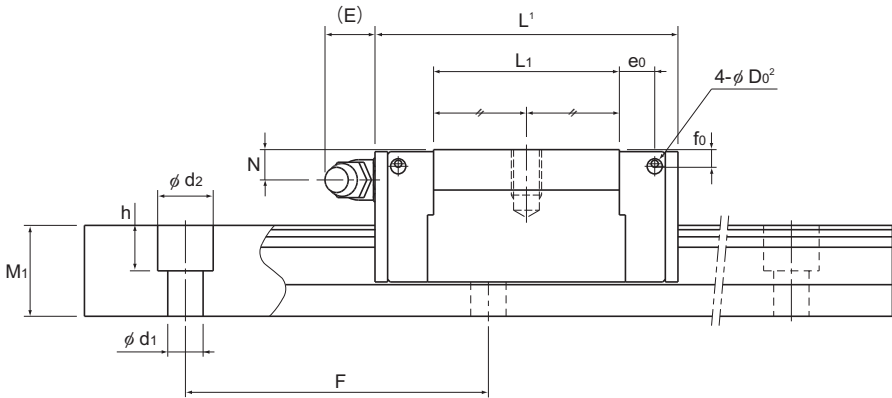

Unit: mm

LM rail dimensions						Basic load rating ¹		Static permissible moment kN·m ⁵					Mass	
Width W ₁ ±0.05	W ₂	Height M ₁	Pitch F	Pitch d ₁ × d ₂ × h	Length ³ Max	C kN	C ₀ kN	M _A		M _B		M _C	LM block kg	LM rail kg/m
								1 block	2 blocks	1 block	2 blocks	1 block		
15	9.5	12.5	60	4.5 × 7.5 × 5.3	3000 (1240)	9.1	9.7	0.0303	0.119	0.0189	0.122	0.0562	0.08	1.2
20	11	15.5	60	6 × 9.5 × 8.5	3000 (1480)	13.4	14.4	0.0523	0.336	0.0326	0.213	0.111	0.14	2.1
23	12.5	18	60	7 × 11 × 9	3000 (2020)	21.7	22.5	0.104	0.661	0.0652	0.419	0.204	0.23	2.7
28	16	23	80	7 × 11 × 9	3000 (2520)	34.8	34.4	0.186	1.12	0.116	0.711	0.376	0.43	4.3
34	18	27.5	80	9 × 14 × 12	3000	48.3	46.7	0.295	1.77	0.184	1.12	0.615	0.6	6.4

¹ Length L shown in the table is the length with the contamination protection accessories, code UU or SS.

If other contamination protection accessories or lubricant equipment are installed, the total block length will increase. (See **A1-521** or **A1-543**)

² D₀ are the pilot holes for when a grease nipple is desired for a product with LaCS or a QZ Lubricator.

Pilot holes are not drilled through for models other than those stated above.

For grease nipple mount machining, contact THK.

³ The maximum length indicates the standard maximum length of an LM rail. (See **A1-118**.)

⁴ The basic load rating is for a load in the radial direction.

Use **A1-61** on Table 7 to calculate the load rating for loads in the reverse-radial direction or lateral direction.

⁵ Static permissible moment 1 block: the static permissible moment with one LM block

2 blocks: the static permissible moment with two LM blocks in close contact with each other

Notes: The M in the model number symbol indicates that the LM block, LM rail and balls are made of stainless steel.

The stainless steel provides excellent corrosion and environmental resistance.

For models SSR15 and 25, two types of rails with different mounting hole dimensions are available. (See Table 1.)

When replacing this model with model SR, pay attention to the mounting hole dimension of the LM rail. Contact THK for details.

Table 1: Rail Mounting Hole Dimensions

Model No.	Standard rail	Semi-standard rail
SSR 15	For M4 (symbol Y)	For M3 (no symbol)
SSR 25	For M6 (symbol Y)	For M5 (no symbol)

Model SSR-XTB

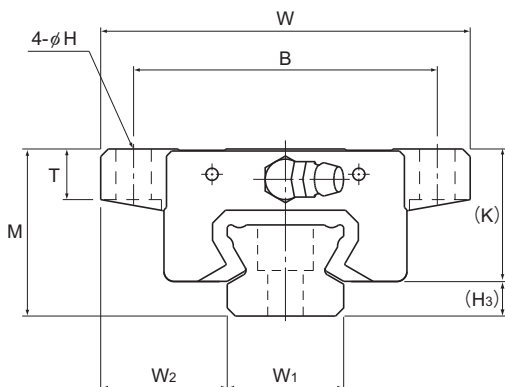

Model No.	Outer dimensions			LM block dimensions									Pilot hole for side nipple			H ₃
	Height	Width	Length ¹	B	C	H	L ₁	T	K	N	E	Grease nipple	e ₀	f ₀	D ₀ ²	
	M	W	L													
SSR 15XTB	24	52	56.9	41	26	4.5	39.9	7	19.5	4.5	5.5	PB1021B	4.5	2.7	3	4.5
SSR 20XTB	28	59	66.5	49	32	5.5	46.6	9	22	5.5	12	B-M6F	5.2	2.9	3	6
SSR 25XTB	33	73	83	60	35	7	59.8	10	26.2	6	12	B-M6F	6.8	3.3	3	6.8
SSR 30XTB	42	90	97	72	40	9	70.7	10	32.5	8	12	B-M6F	7.6	4.5	4	9.5
SSR 35XTB	48	100	110.9	82	50	9	80.5	13	36.5	8.5	12	B-M6F	8.8	4.7	4	11.5

Model number coding

SSR15X TB 2 QZ UU C1 +820L Y P T -II

Model number

Type of LM block

With QZ lubricator

Contamination protection accessory symbol

LM rail length (in mm)

Applied to only 15 and 25 sizes

Symbol for LM rail jointed use

Symbol for No. of rails used on the same plane

No. of LM blocks used on the same rail

Radial clearance symbol
Normal (No symbol)
Light preload (C1)
Medium preload (C0)

Accuracy symbol
Normal grade (No Symbol)
High accuracy grade (H)
Precision grade (P)
Super precision grade (SP)
Ultra precision grade (UP)

Notes: This model number indicates that a single-rail unit constitutes one set (i.e., required number of sets when 2 rails are used in parallel is 2 at a minimum).

Grease nipples are not installed when there is a QZ Lubricator. Contact THK if you want to use a grease nipple for a model with a QZ. See **A1-547** for contamination protection accessories, see **A1-73** for radial clearance symbol. See **A1-79** for accuracy symbol. See **A1-13** for symbol for number of rails used on the same plane.

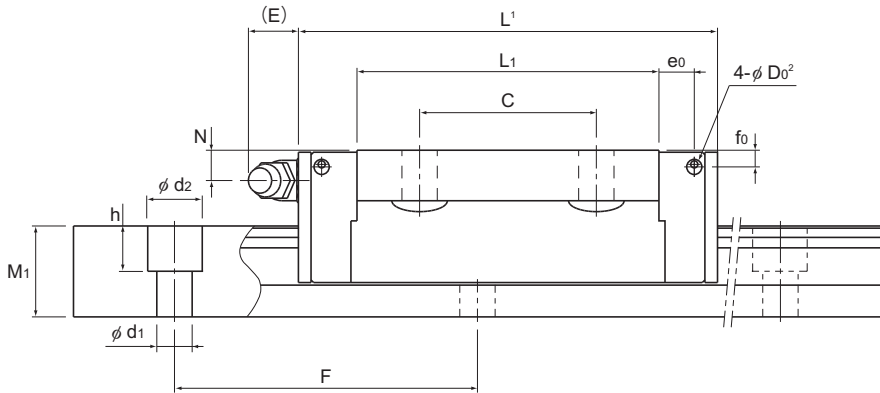

Unit: mm

LM rail dimensions						Basic load rating ¹		Static permissible moment kN·m ⁵					Mass	
Width	Height	Pitch		Length ³	C	C ₀	M _A		M _B		M _C	LM block	LM rail	
W ₁ ±0.05	W ₂	M ₁	F	d ₁ × d ₂ × h	Max	kN	kN	1 block	2 blocks	1 block	2 blocks	1 block	kg	kg/m
15	18.5	12.5	60	4.5 × 7.5 × 5.3	3000 (1240)	14.7	16.5	0.0792	0.44	0.0486	0.274	0.0962	0.19	1.2
20	19.5	15.5	60	6 × 9.5 × 8.5	3000 (1480)	19.6	23.4	0.138	0.723	0.0847	0.448	0.18	0.31	2.1
23	25	18	60	7 × 11 × 9	3000 (2020)	31.5	36.4	0.258	1.42	0.158	0.884	0.33	0.53	2.7
28	31	23	80	7 × 11 × 9	3000 (2520)	46.5	52.7	0.446	2.4	0.274	1.49	0.571	0.87	4.3
34	33	27.5	80	9 × 14 × 12	3000	64.6	71.6	0.711	3.72	0.437	2.31	0.936	1.33	6.4

¹ Length L shown in the table is the length with the contamination protection accessories, code UU or SS.

If other contamination protection accessories or lubricant equipment are installed, the total block length will increase. (See **A1-521** or **A1-543**)

² D₀ are the pilot holes for when a grease nipple is desired for a product with LaCS or a QZ Lubricator.

Pilot holes are not drilled through for models other than those stated above.

For grease nipple mount machining, contact THK.

³ The maximum length indicates the standard maximum length of an LM rail. (See **A1-118**.)

⁴ The basic load rating is for a load in the radial direction.

Use **A1-61** on Table 7 to calculate the load rating for loads in the reverse-radial direction or lateral direction.

⁵ Static permissible moment 1 block: the static permissible moment with one LM block

2 blocks: the static permissible moment with two LM blocks in close contact with each other

Notes: For models SSR15 and 25, two types of rails with different mounting hole dimensions are available. (See Table 1.)

When replacing this model with model SR, pay attention to the mounting hole dimension of the LM rail. Contact THK for details.

Table 1: Rail Mounting Hole Dimensions

Model No.	Standard rail	Semi-standard rail
SSR 15	For M4 (symbol Y)	For M3 (no symbol)
SSR 25	For M6 (symbol Y)	For M5 (no symbol)

Model SSR-XSB

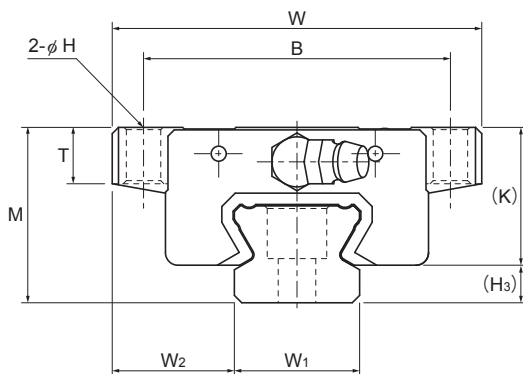

Model No.	Outer dimensions			LM block dimensions								Pilot hole for side nipple			H ₃
	Height	Width	Length ¹	B	H	L ₁	T	K	N	E	Grease nipple	e _a	f _o	D _o ²	
	M	W	L												
SSR 15XSB	24	52	40.3	41	4.5	23.3	7	19.5	4.5	5.5	PB1021B	4.5	2.7	3	4.5
SSR 20XSB	28	59	47.7	49	5.5	27.8	9	22	5.5	12	B-M6F	5.2	2.8	3	6
SSR 25XSB	33	73	60	60	7	36.8	10	26.2	6	12	B-M6F	7	3.3	3	6.8
SSR 30XSB	42	90	66.7	72	9	40.4	10	32.5	8	12	B-M6F	7.6	4.5	4	9.5
SSR 35XSB	48	100	77.5	82	9	47.1	13	36.5	8.5	12	B-M6F	8.8	4.7	4	11.5

Model number coding

SSR15X SB 2 QZ UU C1 +820L Y P T - II

Model number

Type of LM block

No. of LM blocks used on the same rail

With QZ lubricator

Contamination protection accessory symbol

Radial clearance symbol
Normal (No symbol)
Light preload (C1)
Medium preload (C0)

LM rail length (in mm)

Applied to only 15 and 25 sizes

Symbol for LM rail jointed use

Accuracy symbol
Normal grade (No Symbol)
High accuracy grade (H)
Precision grade (P)
Super precision grade (SP)
Ultra precision grade (UP)

Symbol for No. of rails used on the same plane

Notes: This model number indicates that a single-rail unit constitutes one set (i.e., required number of sets when 2 rails are used in parallel is 2 at a minimum).

Grease nipples are not installed when there is a QZ Lubricator. Contact THK if you want to use a grease nipple for a model with a QZ. See **A1-547** for contamination protection accessories, see **A1-73** for radial clearance symbol. See **A1-79** for accuracy symbol. See **A1-13** for symbol for number of rails used on the same plane.

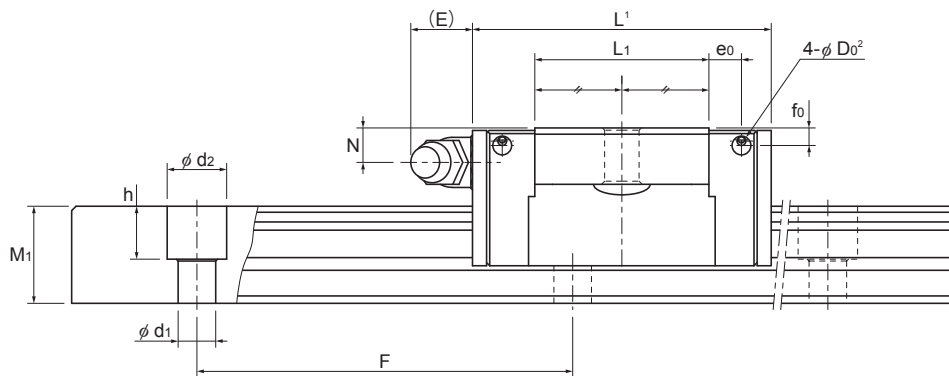

Unit: mm

LM rail dimensions						Basic load rating ¹		Static permissible moment kN·m ⁵					Mass	
Width	Height	Pitch	Length ³	C	C ₀	M _A		M _B		M _C	LM block	LM rail		
W ₁ ±0.05	W ₂	M ₁	F	d ₁ × d ₂ × h	Max	kN	kN	1 block	2 blocks	1 block	2 blocks	1 block	kg	kg/m
15	18.5	12.5	60	4.5 × 7.5 × 5.3	3000 (1240)	9.1	9.7	0.0303	0.1192	0.0189	0.122	0.0562	0.11	1.2
20	19.5	15.5	60	6 × 9.5 × 8.5	3000 (1480)	13.4	14.4	0.0523	0.336	0.0326	0.213	0.111	0.18	2.1
23	25	18	60	7 × 11 × 9	3000 (2020)	21.7	22.5	0.104	0.661	0.0652	0.419	0.204	0.31	2.7
28	31	23	80	7 × 11 × 9	3000 (2520)	34.8	34.4	0.186	1.12	0.116	0.711	0.376	0.52	4.3
34	33	27.5	80	9 × 14 × 12	3000	48.3	46.7	0.295	1.77	0.184	1.12	0.615	0.77	6.4

¹ Length L shown in the table is the length with the contamination protection accessories, code UU or SS.
If other contamination protection accessories or lubricant equipment are installed, the total block length will increase. (See **A1-521** or **A1-543**)

² D₀ are the pilot holes for when a grease nipple is desired for a product with LaCS or a QZ Lubricator.
Pilot holes are not drilled through for models other than those stated above.
For grease nipple mount machining, contact THK.

³ The maximum length indicates the standard maximum length of an LM rail. (See **A1-118**.)

⁴ The basic load rating is for a load in the radial direction.
Use **A1-61** on Table 7 to calculate the load rating for loads in the reverse-radial direction or lateral direction.

⁵ Static permissible moment 1 block: the static permissible moment with one LM block
2 blocks: the static permissible moment with two LM blocks in close contact with each other

Notes: For models SSR15 and 25, two types of rails with different mounting hole dimensions are available. (See Table 1.)
When replacing this model with model SR, pay attention to the mounting hole dimension of the LM rail. Contact THK for details.

Table 1: Rail Mounting Hole Dimensions

Model No.	Standard rail	Semi-standard rail
SSR 15	For M4 (symbol Y)	For M3 (no symbol)
SSR 25	For M6 (symbol Y)	For M5 (no symbol)

Standard Lengths and Maximum Lengths of LM Rails

Table 1 shows the standard lengths and the maximum lengths of model SSR variations. If the maximum length of the desired LM rail exceeds these values, joint rails will be used. Contact THK for details. For special rail lengths, it is recommended to use a value corresponding to the G and g dimensions from the table. As the G and g dimensions increase, this portion becomes less stable, and the accuracy performance is severely impacted.

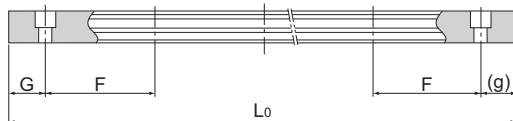

Table 1: Standard Lengths and Maximum Lengths of LM Rails

Unit: mm

Model No.	SSR 15X	SSR 20X	SSR 25X	SSR 30X	SSR 35X
LM rail standard lengths (L_0)	160	220	220	280	280
	220	280	280	360	360
	280	340	340	440	440
	340	400	400	520	520
	400	460	460	600	600
	460	520	520	680	680
	520	580	580	760	760
	580	640	640	840	840
	640	700	700	920	920
	700	760	760	1000	1000
	760	820	820	1080	1080
	820	940	940	1160	1160
	940	1000	1000	1240	1240
	1000	1060	1060	1320	1320
	1060	1120	1120	1400	1400
	1120	1180	1240	1480	1480
	1180	1240	1300	1640	1640
	1240	1300	1360	1720	1720
	1300	1360	1420	1800	1800
	1360	1420	1480	1880	1880
	1420	1480	1540	1960	1960
	1480	1540	1600	2040	2040
	1540	1600	1660	2120	2120
		1660	1720	2200	2200
		1720	1780	2280	2280
		1780	1840	2360	2360
		1840	1900	2440	2440
		1900	1960	2520	2520
	1960	2020	2600	2600	
	2020	2080	2680	2680	
	2080	2140	2760	2760	
	2140	2200	2840	2840	
		2260	2920	2920	
		2320			
		2380			
		2440			
Standard pitch F	60	60	60	80	80
G, g	20	20	20	20	20
Max length	3000 (1240)	3000 (1480)	3000 (2020)	3000 (2520)	3000

Notes: The maximum length varies with accuracy grades. Contact THK for details.

If jointed rails are not allowed and a greater length than the maximum values above is required, contact THK.

The figures in the parentheses indicate the maximum lengths of stainless steel made models.

Tapped-Hole Type LM Rail

LM rails with tapped holes machined on the bottom surface are available for the Model SSR. This type is useful when mounting from the bottom of the base and when increased contamination protection is desired.

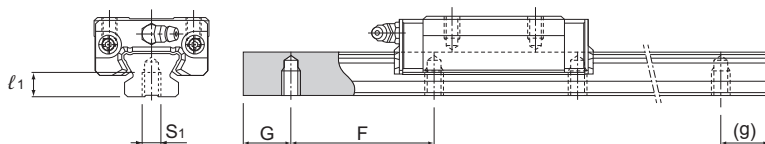

- (1) A tapped-hole LM rail type is available only for Precision grade or lower grades.
- (2) For standard pitches of the taps and the G and g dimensions, see Table 1 on **A1-118**.

Table 2: Dimensions of the LM Rail Tap Unit: mm

Model No.	S ₁	Effective tap depth l_1
SSR 15X	M5	7
SSR 20X	M6	9
SSR 25X	M6	10
SSR 30X	M8	14
SSR 35X	M8	16

Model number coding

SSR20XW2UU+1200LH K

Symbol for
tapped-hole LM rail