

HR

Separate Type (4-Way Equal Load) LM Guide Model HR

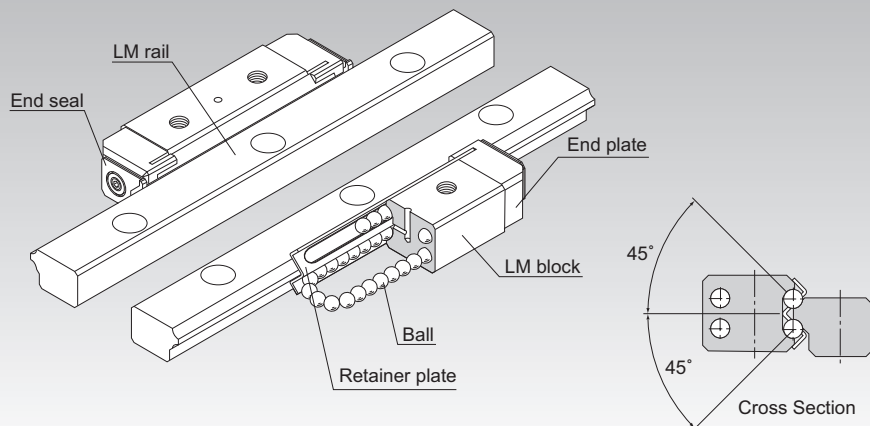

Selection Criteria	A1-10
Design Highlights	A1-482
Options	A1-507
Model No.	A1-577
Handling Precautions	A1-583
Accessories for Lubrication	A24-1
Mounting Procedure	B1-89
Equivalent Moment Factor	A1-43
Rated Loads in All Directions	A1-61
Equivalent Factor in Each Direction	A1-63
Example of Clearance Adjustment	A1-281
Accuracy Standards	A1-83
Shoulder Height of the Mounting Base and the Corner Radius	A1-496
Reference Error Tolerance for the Mounting Surface	A1-499
Dimensions of Each Model with Options Attached	A1-521

Structure and Features

Balls roll in two rows of raceways precision-ground on an LM rail and an LM block, and end plates incorporated in the LM block allow the balls to circulate. Since retainer plates hold the balls, they will not fall out.

Each of the two rows of balls that circulate through the LM rail contact the raceway at a 45° angle. With this angular contact structure, installing one set (a combination of two LM rails and LM blocks on the same plane) on a flat surface allows the system to bear an equal load in all four directions (radial, reverse-radial, and horizontal directions). In addition, because the cross-sectional height is low, this linear motion guide configuration provides stability in a compact form.

Clearance adjustments are relatively easy to perform, and the product is highly capable of absorbing mounting error.

Easy Installation

With Model HR, it is easier to adjust clearance and achieve accuracy than with cross-roller guides.

Self-Adjustment Capability

Even with poor parallelism or level between the two rails, the self-adjustment capability in the front-to-front configuration of THK's unique circular-arc grooves (DF set) absorbs mounting error and achieves smooth linear motion, even under a preload.

4-Way Equal Load

When the two rails are mounted in parallel, each row of balls is placed at a contact angle of 45° so that the load ratings applied to the LM block are uniform in the four directions (radial, reverse-radial, and lateral directions), enabling the LM Guide to be used in various orientations.

Cross-Sectional Dimensions Approximate to Cross-Roller Guides

Since Model HR utilizes end caps for recirculation, it is not susceptible to the cage displacement that occurs in cross-roller guides. In addition, the cross-sectional shape of Model HR is similar to that of cross-roller guides, and the two product types are interchangeable.

Stainless Steel Type also Available

A special type whose LM block, LM rail, and balls are made of stainless steel is also available.

Types and Features

Model HR - Heavy-Load Type

The LM blocks can be mounted from the top and the bottom.

Dimensional Table → [A1-284](#)

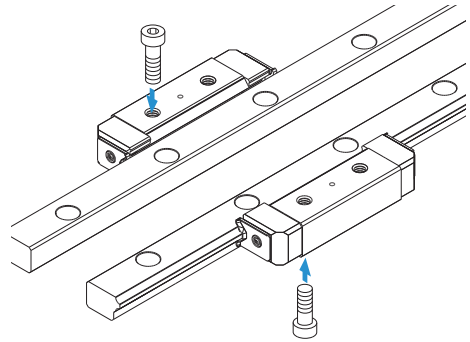

Model HR-T - Super-Heavy Load Type

This model has the same cross-sectional shape as model HR, but has a greater overall LM block length (L) and a higher load rating.

Dimensional Table → [A1-284](#)

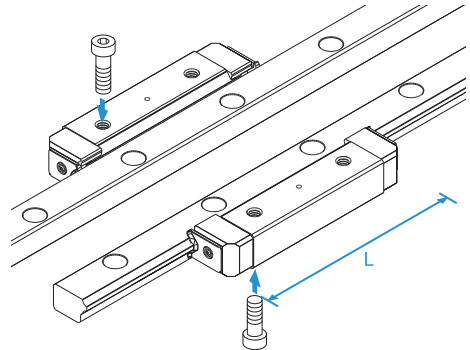

Example of Clearance Adjustment

Design the clearance adjustment bolt so that it presses the center of the side face of the LM block.

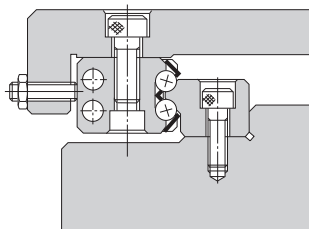

- a. Using an adjustment screw
Normally, an adjustment screw is used to press the LM block.

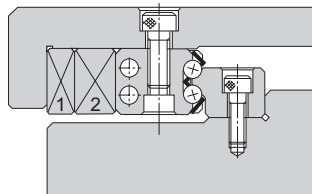

- b. Using tapered gibs
When high accuracy and high rigidity are required, use tapered gibs 1) and 2).

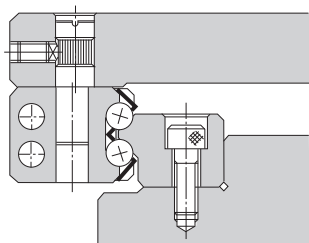

- c. Using an eccentric pin
A type using an eccentric pin to adjust the clearance is also available.

Comparable Cross-Roller Guide Model Numbers

Each type of LM Guide Model HR has cross-sectional dimensions approximate to those of a corresponding cross-roller guide model.

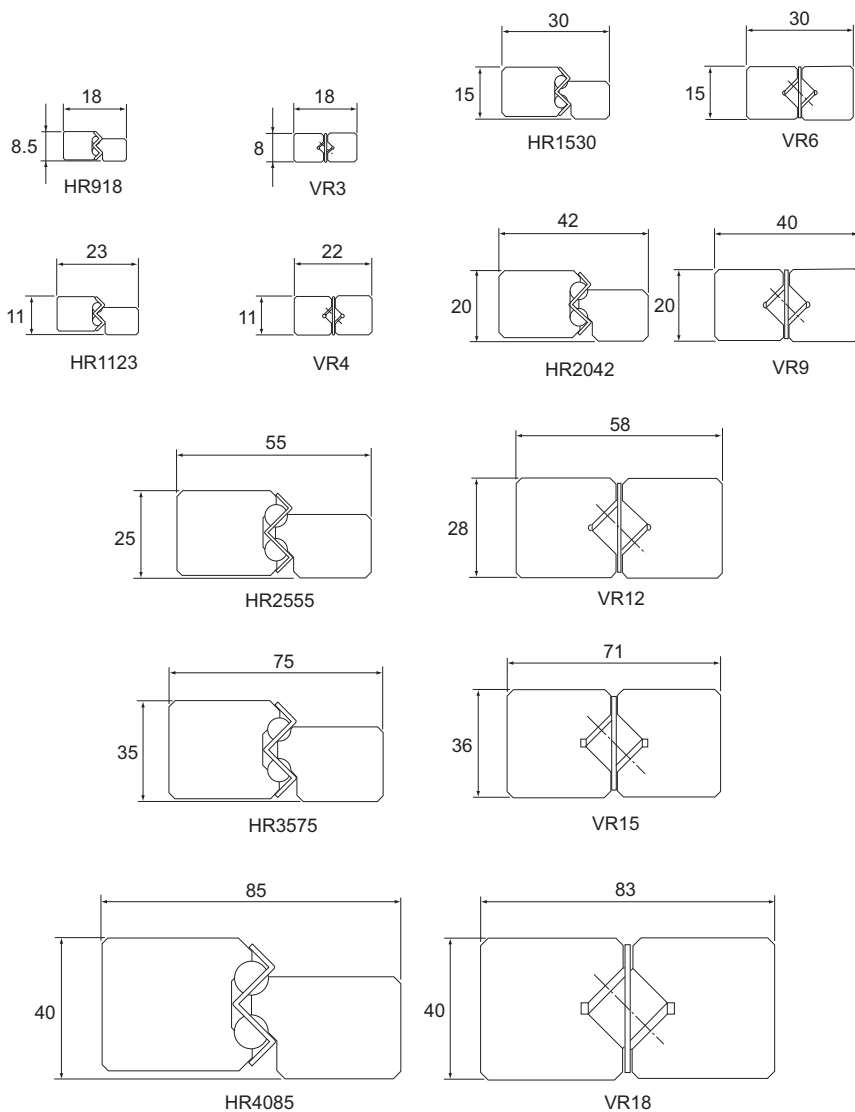
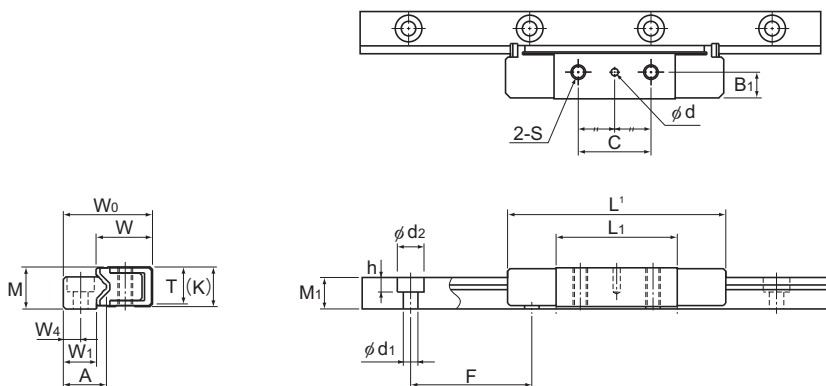

Fig. 1

Models HR, HR-T, HR-M, and HR-TM



Models HR918 and 918M

Model No.	Outer dimensions				LM block dimensions									
	Height	Width		Length ¹									Lubrication hole	
	M	W	W ₀	L	B ₁	C	H	S	h ₂	L ₁	T	K	d	D ₁
HR 918 HR 918M	8.5	11.4	18	45	5.5	15	—	M3	—	25	7.5	8	1.5	—
HR 1123 HR 1123M	11	13.7	23	52	7	15	2.55	M3	3	30	9.5	10	2	5
HR 1530 HR 1530M	15	19.2	30	69	10	20	3.3	M4	3.5	40	13	14	2	6.5
HR 2042 HR 2042M	20	26.3	42	91.6	13	35	5.3	M6	5.5	56.6	17.5	19	3	10
HR 2042T HR 2042TM	20	26.3	42	110.7	13	50	5.3	M6	5.5	75.7	17.5	19	3	10
HR 2555 HR 2555M	25	33.3	55	121	16	45	6.8	M8	7	80	22.5	24	3	11
HR 2555T HR 2555TM	25	33.3	55	146.4	16	72	6.8	M8	7	105.4	22.5	24	3	11

Model number coding

2 HR2555 UU M +1000L P T M

2	HR2555	UU	M	+1000L	P	T	M
No. of LM blocks used on the same rail	Model number	Contamination protection accessory symbol	Stainless steel LM block	LM rail length (in mm)	Symbol for LM rail jointed use	Accuracy symbol	Stainless steel LM rail
						Normal grade (No Symbol)/High accuracy grade (H) Precision grade (P)/Super precision grade (SP) Ultra precision grade (UP)	

Notes: One set of model HR means a combination of two LM rails and LM blocks used on the same plane.

See **A1-547** for contamination protection accessories. See **A1-83** for accuracy symbol.

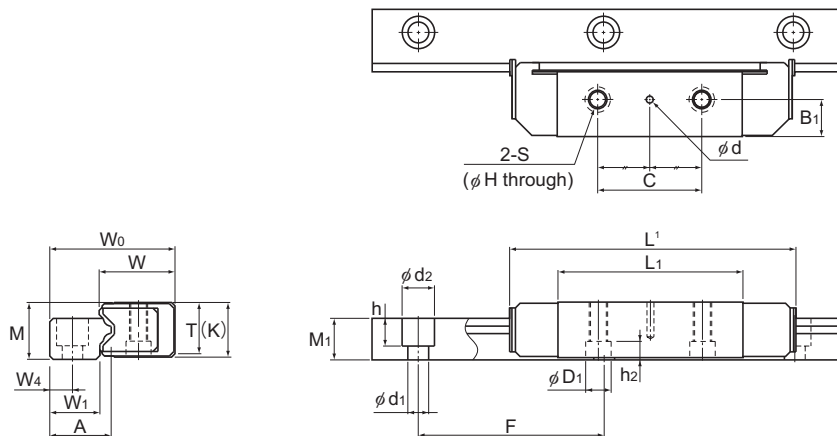

Models HR1123 to 2555M/T/TM

Unit: mm

LM rail dimensions								Basic load rating		Static permissible moment kN·m ³				Mass	
Width	Width	Width	Height	Pitch	Pitch	Length ²	C	C ₀	M _A		M _B		LM block	LM rail	
									1 block	2 blocks	1 block	2 blocks			
W ₁	W ₄	A	M ₁	F	d ₁ × d ₂ × h	Max	kN	kN					kg	kg/m	
6.7	3.5	8.7	6.5	25	3 × 5.5 × 3	300 (300)	2.82	3.48	0.0261	0.194	0.0261	0.194	0.01	0.3	
9.5	5	11.6	8	40	3.5 × 6 × 4.5	500 (500)	4.09	4.93	0.0472	0.311	0.0472	0.311	0.03	0.5	
10.7	6	13.5	11	60	3.5 × 6 × 4.5	1600 (800)	7.56	8.77	0.112	0.733	0.112	0.733	0.08	1	
15.6	8	19.5	14.5	60	6 × 9.5 × 8.5	2200 (1000)	17	18.2	0.325	2.01	0.325	2.01	0.13	1.8	
15.6	8	19.5	14.5	60	6 × 9.5 × 8.5	2200 (1000)	20.8	24.3	0.56	3.16	0.56	3.16	0.26	1.8	
22	10	27	18	80	9 × 14 × 12	3000 (1000)	33.2	35.1	0.897	5.04	0.897	5.04	0.43	3.2	
22	10	27	18	80	9 × 14 × 12	3000 (1000)	40	45.9	1.49	7.8	1.49	7.8	0.5	3.2	

¹ Length L shown in the table is the length with the contamination protection accessories (code: UU).

² The maximum length indicates the standard maximum length of an LM rail. (See **A1-288**.)

³ Static permissible moment 1 block: the static permissible moment value with two LM rails, one LM block per rail, used on the same plane
 2 blocks: static permissible moment when two LM blocks are in close contact with each other on two LM rails used on the same plane

A moment in the M_z direction can be received if two rails are used in parallel. However, since it depends on the distance between the two rails, it has been omitted.

Notes: The M in the model number symbol indicates that the LM block, LM rail and balls are made of stainless steel.

The stainless steel provides excellent corrosion and environmental resistance.

Models HR, HR-T, HR-M, and HR-TM

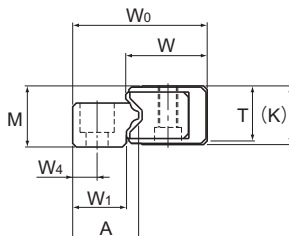

Model No.	Outer dimensions				LM block dimensions									
	Height M	Width W	W ₀	Length ¹ L	B ₁	C	H	S	h ₂	L ₁	T	K	Lubrication hole d	D ₁
HR 3065 HR 3065T	30	40.3	65	145 173.5	19	50 80	8.6	M10	9	90 118.5	27.5	29	4	14
HR 3575 HR 3575T	35	44.9	75	154.8 182.5	21.5	60 92.5	10.5	M12	12	103.8 131.5	32	34	4	18
HR 4085 HR 4085T	40	50.4	85	177.8 215.9	24	70 110	12.5	M14	13	120.8 158.9	36	38	4	20
HR 50105 HR 50105T	50	63.4	105	227 274.5	30	85 130	14.5	M16	15.5	150 197.5	45	48	5	23
HR 60125	60	74.4	125	329	35	160	18	M20	18	236	55	58	5	26

Model number coding

2 HR4085T UU +1500L P T

Model number
No. of LM blocks
used on the same rail

Contamination
protection
accessory
symbol

LM rail length
(in mm)

Symbol for LM rail
jointed use

Accuracy symbol
Normal grade (No Symbol)/High accuracy grade (H)
Precision grade (P)/Super precision grade (SP)
Ultra precision grade (UP)

Notes: One set of model HR means a combination of two LM rails and LM blocks used on the same plane.
See **A1-547** for contamination protection accessories. See **A1-83** for accuracy symbol.

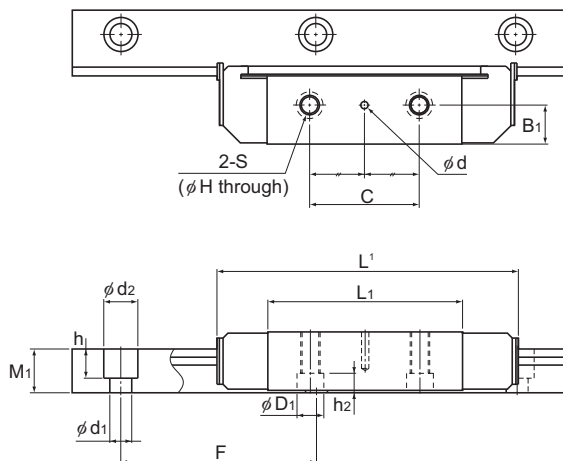

Unit: mm

LM rail dimensions							Basic load rating		Static permissible moment kN·m ³				Mass	
Width			Height	Pitch		Length ²	C	C ₀	M_A		M_B		LM block	LM rail
W ₁	W ₄	A	M ₁	F	d ₁ × d ₂ × h	Max	kN	kN	1 block	2 blocks	1 block	2 blocks	kg	kg/m
25	12	31.5	22.5	80	9 × 14 × 12	3000	42.6 51.5	44.4 58.1	1.27 2.12	7.71 11.7	1.27 2.12	7.71 11.7	0.7 0.9	4.6
30.5	14.5	37	26	105	11 × 17.5 × 14	3000	53.5 64.4	54.8 71.7	1.75 2.91	10.1 15.2	1.75 2.91	10.1 15.2	1.05 1.4	6.4
35	16	42.5	29	120	14 × 20 × 17	3000	78.8 95.1	78.9 103	3.02 5.02	16.6 25.7	3.02 5.02	16.6 25.7	1.53 1.7	8
42	20	51.5	37	150	18 × 26 × 22	3000	127 153	123 161	5.89 9.81	33.1 51.3	5.89 9.81	33.1 51.3	3.06 3.5	12.1
51	25	65	45	180	22 × 32 × 25	3000	226	232	16	89.5	16	89.5	7.5	19.3

¹ Length L shown in the table is the length with the contamination protection accessories (code: UU).

² The maximum length indicates the standard maximum length of an LM rail. (See **A1-288**.)

³ Static permissible moment 1 block: the static permissible moment value with two LM rails, one LM block per rail, used on the same plane
2 blocks: static permissible moment when two LM blocks are in close contact with each other on two LM rails used on the same plane

A moment in the M_B direction can be received if two rails are used in parallel. However, since it depends on the distance between the two rails, it has been omitted.

Notes: The M in the model number symbol indicates that the LM block, LM rail and balls are made of stainless steel.

The stainless steel provides excellent corrosion and environmental resistance.

Standard Lengths and Maximum Lengths of LM Rails

Table 1 shows the standard lengths and the maximum lengths of model HR variations. If the maximum length of the desired LM rail exceeds these values, jointed rails will be used. Contact THK for details.

For special rail lengths, it is recommended to use a value corresponding to the G and g dimensions from the table. As the G and g dimensions increase, this portion becomes less stable, and the accuracy performance is severely impacted.

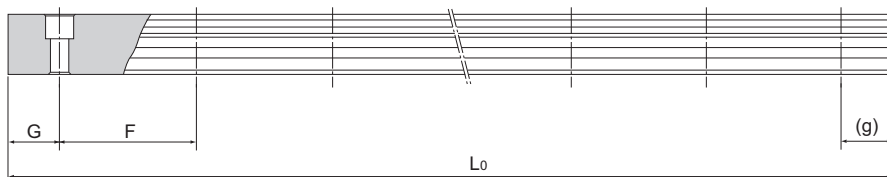

Table 1: Standard Lengths and Maximum Lengths of LM Rails for Model HR

Unit: mm

Model No.	HR 918	HR 1123	HR 1530	HR 2042	HR 2555	HR 3065	HR 3575	HR 4085	HR 50105	HR 60125
LM rail standard lengths (L ₀)	70	110	160	220	280	280	570	780	1270	1530
	120	230	280	280	440	440	885	1020	1570	1890
	220	310	340	340	600	600	1200	1260	2020	2250
	295	390	460	460	760	760	1620	1500	2620	2610
		580	640	1000	1000	1240	2040	1980		
				1240	1240	2460	2580			
Standard pitch F	25	40	60	60	80	80	105	120	150	180
G, g	10	15	20	20	20	20	22.5	30	35	45
Max length	300 (300)	500 (500)	1600 (800)	2200 (1000)	3000 (1000)	3000	3000	3000	3000	3000

Notes: The maximum length varies with accuracy grades. Contact THK for details.

If jointed rails are not allowed and a greater length than the maximum values above is required, contact THK.

The figures in the parentheses indicate the maximum lengths of stainless steel made models.

Accessories

Dedicated Mounting Bolt

Normally, when mounting the LM block on the side that will be used for clearance adjustment, use the tapped hole provided on the LM block to secure it as shown in Fig. 2.

The holes of the bolt (d_1 and D_1) must be machined so that they are larger by the amount of the adjustment allowance.

If structural reasons require a mounting method similar to Fig. 3, the dedicated mounting bolt as shown in Fig. 4 is required for securing the LM block. Be sure to specify that the dedicated mounting bolt is required when ordering the LM Guide.

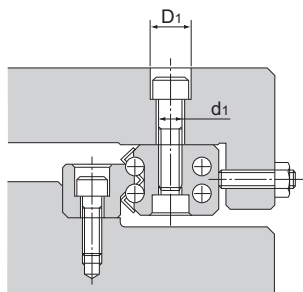

Fig. 2

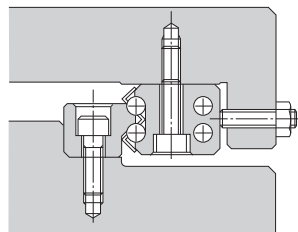

Fig. 3

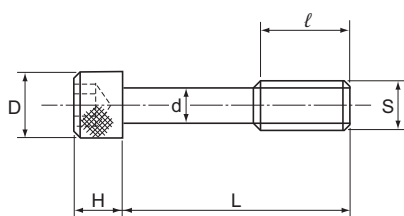

Fig. 4

Table 2: Dedicated Mounting Bolt Unit: mm

Model No.	S	d	D	H	L	ℓ	Supported model number
B 3	M3	2.4	5.5	3	17	5	HR 1530
B 5	M5	4.1	8.5	5	22	7	HR 2042
B 6	M6	4.9	10	6	28	9	HR 2555
B 8	M8	6.6	13	8	34	12	HR 3065
B 10	M10	8.3	16	10	39	15	HR 3575
B 12	M12	10.1	18	12	45	18	HR 4085
B 14	M14	11.8	21	14	55	21	HR 50105
B 16	M16	13.8	24	16	66	24	HR 60125

Lubrication Hole

Lubrication for Model HR

The LM block has a lubrication hole in the center of its top face. To provide lubrication through this hole, the table must be machined to also have a lubrication hole as shown in Fig. 5 and attach a grease nipple or the like. When using oil lubrication, it is necessary to identify the lubrication route. Contact THK for details.

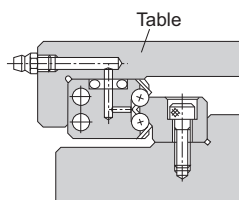

Fig. 5: Example of Machining a Lubrication Hole

