

GSR

Separate Type (Radial) LM Guide Model GSR

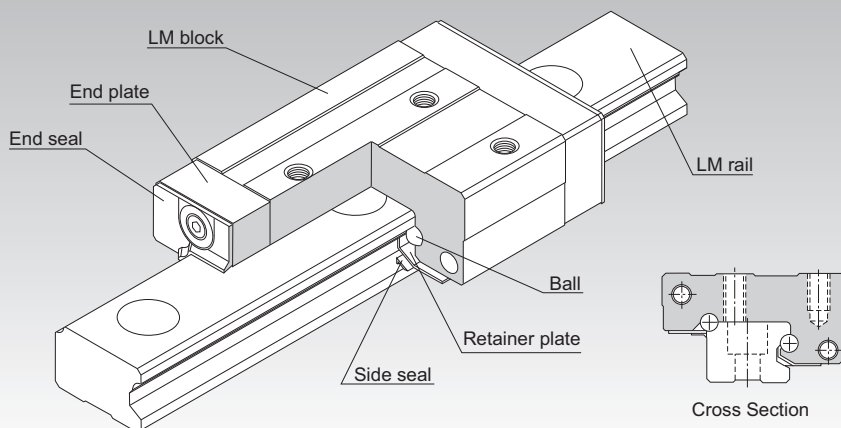

Selection Criteria **A1-10**

Design Highlights **A1-482**

Options **A1-507**

Model No. **A1-577**

Handling Precautions **A1-583**

Accessories for Lubrication **A24-1**

Mounting Procedure **B1-89**

Equivalent Moment Factor **A1-43**

Rated Loads in All Directions **A1-61**

Equivalent Factor in Each Direction **A1-63**

Example of Clearance Adjustment **A1-295**

Accuracy Standards **A1-84**

Shoulder Height of the Mounting Base and the Corner Radius **A1-496**

Reference Error Tolerance for the Mounting Surface **A1-499**

Dimensions of Each Model with Options Attached **A1-521**

Structure and Features

Balls roll in two rows of raceways precision-ground on an LM rail and an LM block, and end plates incorporated in the LM block allow the balls to circulate. Since retainer plates hold the balls, they will not fall out.

Because the top face of the LM block is inclined, clearance is eliminated and an appropriate preload is applied simply by securing the LM block with mounting bolts.

Model GSR has a special contact structure using circular-arc grooves. This increases self-adjusting capability and makes GSR an optimal model for places associated with difficulty establishing high accuracy and for general industrial machinery.

Note: Model GSR cannot be used in single-axis applications.

Interchangeability

Both the LM block and LM rail are interchangeable and can be stored separately. Therefore, it is possible to store a long-size LM rail and cut it to a desired length before using it.

Compact

Model GSR's low center of gravity and low overall height help reduce the size of machines.

Capable of Receiving a Load in any Direction

The ball contact angle is designed so that this model can receive a load in any direction. As a result, it can be used in places where a reverse-radial load, lateral load, or a moment in any direction is applied.

Types and Features

Model GSR-T

This model is the standard type.

Dimensional Table⇒ **A1-296**

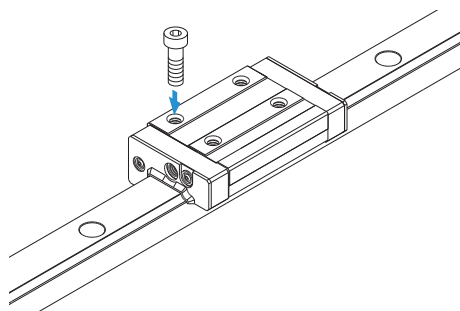

Model GSR-V

This is a space-saving type that has the same cross-sectional shape as GSR-T, but has a shorter overall LM block length (L).

Dimensional Table⇒ **A1-296**

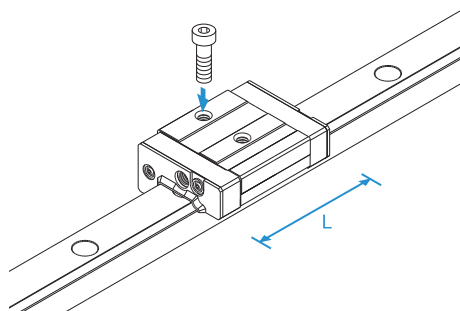

Example of Clearance Adjustment

By providing a shoulder on the side face of each LM block and pressing either LM block with a bolt, a preload can be applied and the rigidity increased.

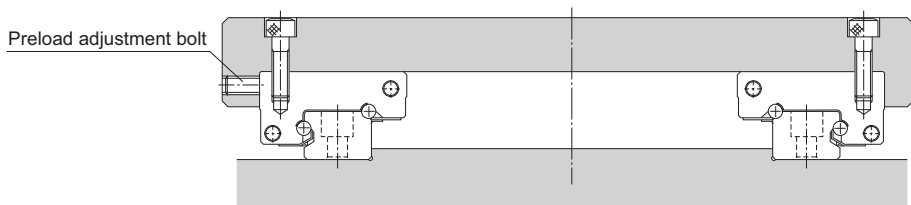
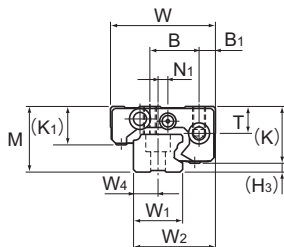
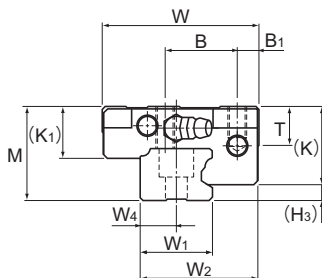

Fig. 1: Example of Adjusting a Preload with a Push Bolt

Models GSR-T and GSR-V



Model GSR15T/V



Models GSR20 to 35T, Models GSR20V, and 25V

Model No.	Outer dimensions			LM block dimensions													H ₃
	Height	Width	Length ¹	B ₁	B	C	S × ℓ	L ₁	T	K	K ₁	N	N ₁	E	Grease nipple		
	M	W	L														
GSR 15V GSR 15T	20	32	47.1 59.8	5	15	— 26	M4 × 7	27.5 40.2	8.25	16.8	12	4.5	3	5.5	PB107	3.2	
GSR 20V GSR 20T	24	43	58.1 74	7	20	— 30	M5 × 8	34.3 50.2	9.7	20.6	13.6	5	—	12	B-M6F	3.4	
GSR 25V GSR 25T	30	50	69 88	7	23	— 40	M6 × 10	41.2 60.2	12.7	25.4	16.8	7	—	12	B-M6F	4.6	
GSR 30T	33	57	103	8	26	45	M8 × 12	70.3	14.6	28.5	18	7	—	12	B-M6F	4.5	
GSR 35T	38	68	117	9	32	50	M8 × 15	80.3	15.6	32.5	20.5	8	—	12	B-M6F	5.5	

Model number coding

Combination of LM rail and LM block

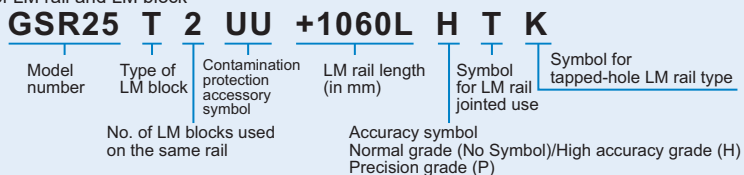

Notes: One set of model GSR. This model number indicates that a single-rail unit constitutes one set.
See **A1-547** for contamination protection accessories. See **A1-84** for accuracy symbol.

LM block

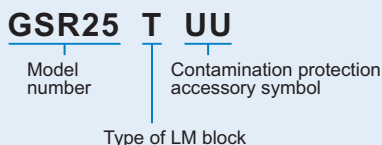

LM rail

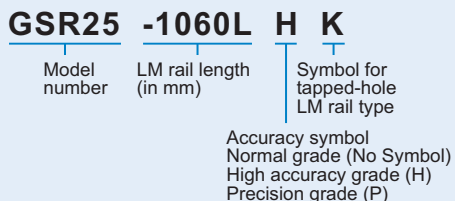

Notes: See **A1-547** for contamination protection accessories. See **A1-84** for accuracy symbol.

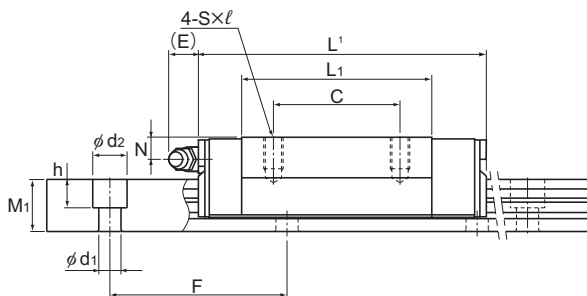

Models GSR15 to 35T

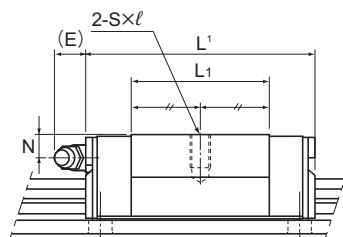

Models GSR15 to 25V

Unit: mm

LM rail dimensions								Basic load rating ¹		Static permissible moment kN·m ⁴				Mass	
Width	W ₂	W ₄	Height	Pitch	F	d ₁ × d ₂ × h	Length ²	C	C ₀	M _A		M _B		LM block	LM rail
										1 block	2 blocks	1 block	2 blocks		
15	25	7.5	11.5	60	60	4.5 × 7.5 × 5.3	2000	6.51 8.42	6.77 9.77	0.0305 0.0606	0.19 0.337	0.0264 0.0523	0.165 0.29	0.08 0.13	1.2
20	33	10	13	60	60	6 × 9.5 × 8.5	3000	10.5 13.6	10.6 15.3	0.06 0.118	0.368 0.652	0.052 0.102	0.318 0.562	0.17 0.25	1.8
23	38	11.5	16.5	60	60	7 × 11 × 9	3000	15.5 20	15.2 22	0.102 0.205	0.625 1.11	0.0891 0.176	0.541 0.961	0.29 0.5	2.6
28	44.5	14	19	80	80	9 × 14 × 12	3000	27.8	29.9	0.325	1.77	0.28	1.52	0.6	3.6
34	54	17	22	80	80	11 × 17.5 × 14	3000	37	39.1	0.485	2.63	0.419	2.27	1	5

¹ Length L shown in the table is the length with the contamination protection accessories, code UU or SS.

If other contamination protection accessories or lubricant equipment are installed, the total block length will increase. (See [A1-521](#) or [A1-543](#))

² The maximum length indicates the standard maximum length of an LM rail. (See [A1-298](#).)

³ The basic load rating is for a load in the radial direction.

Use [A1-61](#) on Table 7 to calculate the load rating for loads in the reverse-radial direction or lateral direction.

⁴ Static permissible moment 1 block: the static permissible moment with one LM block

2 blocks: the static permissible moment with two LM blocks in close contact with each other

A moment in the M_B direction can be received if two rails are used in parallel. However, since it depends on the distance between the two rails, it has been omitted.

Note: For oil lubrication, be certain to let THK know the mounting orientation and where the LM block piping joint should be attached.

(Mounting orientation: see [A1-12](#), Lubricant: see [A24-2](#))

Standard Lengths and Maximum Lengths of LM Rails

Table 1 shows the standard lengths and the maximum lengths of model GSR variations. For customers requiring a large quantity of rails in different lengths, it is more economical to prepare a stock of LM rail of the maximum length and cut the rail to the desired length as necessary.

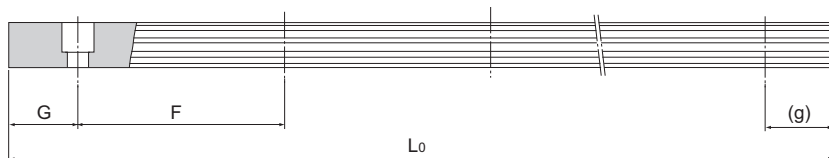

Table 1: Standard Lengths and Maximum Lengths of LM Rails for Model GSR

Unit: mm

Model No.	GSR 15	GSR 20	GSR 25	GSR 30	GSR 35
LM rail standard lengths (L_0)	460	460	460	1240	1240
	820	820	820	1720	1720
	1060	1060	1060	2200	2200
	1600	1600	1600	3000	3000
Standard pitch F	60	60	60	80	80
G, g	20	20	20	20	20
Max length	2000	3000	3000	3000	3000

Note: The maximum length varies with accuracy grades. Contact THK for details.

Tapped-Hole Type LM Rail

- Since the bottom of the LM rail has a tapped hole, this model can easily be installed on a steel H-beam or channel.
- Since the top face of the LM rail has no mounting hole, it provides a better seal and prevents the entrance of foreign material (e.g., cutting chips).

(1) As shown in Fig. 2, a tapered washer is also available that allows GSR to be mounted on a steel flange.

(2) For model number coding, see **A1-296**.

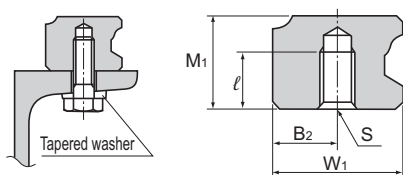

Fig. 2

Table 2: Tap Profile and Depth at Each Position

Model No.	W_1	B_2	M_1	$S \times l$
GSR 15	15	7.5	11.5	M4 × 7
GSR 20	20	10	13	M5 × 8
GSR 25	23	11.5	16.5	M6 × 10
GSR 30	28	14	19	M8 × 12
GSR 35	34	17	22	M10 × 14

