

THK

NEW

Cross Roller Ring for Robots

RF

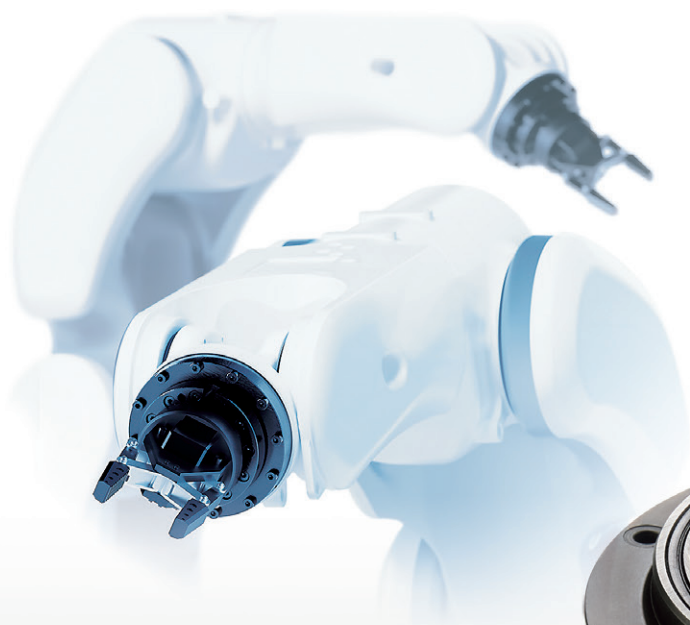

Easy to install
Fewer mounting components
Reduced weight

Introducing the Flanged Cross Roller Ring Model RF





Cross Roller Ring for Robots

RF

Feature 1 Thin, Lightweight, Flanged Design

Feature 2 Reduced Weight and Number of Robot Components



Since the Model RF is lightweight, it is also suitable for applications such as ceiling-mounted rotating arms. Additionally, it is capable of smooth rotary motion because it can receive loads and moments in any direction.

RF Series

Feature 1 Thin, Lightweight, Flanged Design

The unique flanged design achieves an even lighter weight.

Mass Comparison (between models with equal outer diameters and dimensions)

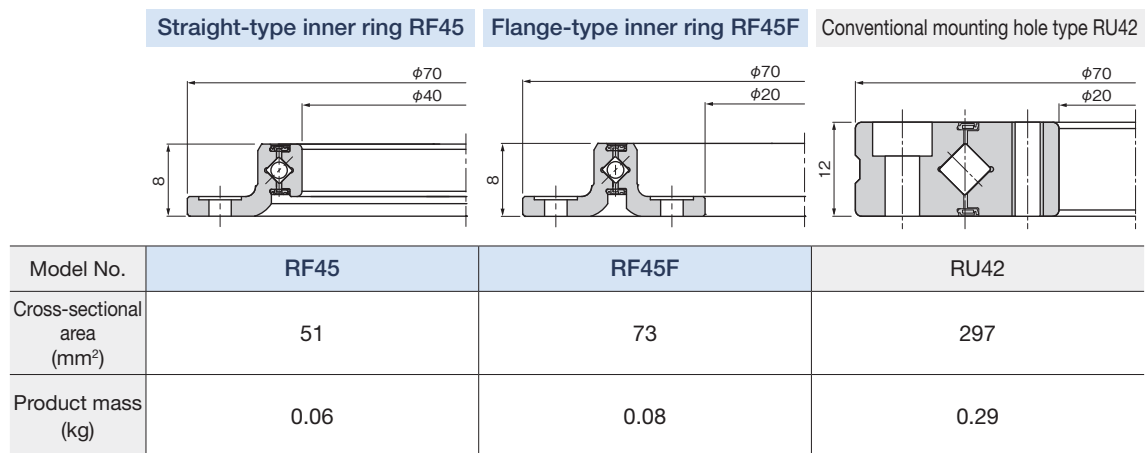

Feature 2 Reduced Weight and Number of Robot Components

This is the ideal product for robots requiring weight reduction and improved productivity.

Mass Comparison (between models with equal outer diameters and dimensions)

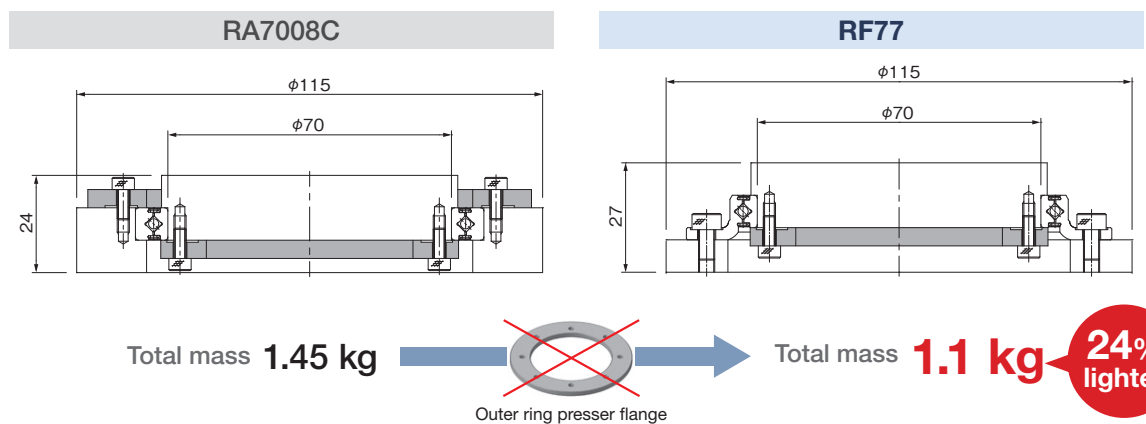

- Can be installed directly onto a shaft or housing → Increases a robot's productivity
- Does not require a presser flange → Simplifies design and reduces installation time
- Reduces product weight → Allows lighter weights than conventional products



Structure

The cross array of rollers allows a single bearing to receive loads and moments in all directions.

The flanged design simplifies installation and minimizes the cross-sectional area of the product.

This is a lightweight unit that maintains the ease of assembly achieved by the Model RU, a conventional cross roller ring with mounting holes.

Lineup

Straight-Type Inner Ring

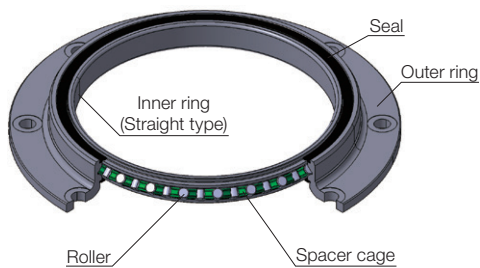

- Leaves open space inside the ring
Allows for high levels of freedom in design and provides space for wiring, etc.
- Same inner ring dimensions as the Model RA
Can easily replace existing equipment.

Shaft diameter	Model No.
40	RF45
50	RF57
60	RF67
70	RF77
90	RF97
120	RF127

Flange-Type Inner Ring



- Flanged inner and outer rings
Shorten assembly time and make devices more lightweight.

Shaft diameter	Model No.
20	RF45F
30	RF57F
40	RF67F
45	RF77F
65	RF97F
95	RF127F

Accuracy Standards

Rotational Accuracy

Rotational Accuracy of the Inner Ring Unit: μm

Model No.	Radial runout tolerance of the inner ring	Axial runout tolerance of the inner ring
RF45	13	13
RF57	13	13
RF67	13	13
RF77	15	15
RF97	15	15
RF127	20	20

Rotational Accuracy of the Inner Ring Unit: μm

Model No.	Radial runout tolerance of the inner ring	Axial runout tolerance of the inner ring
RF45F	13	13
RF57F	13	13
RF67F	15	15
RF77F	15	15
RF97F	20	20
RF127F	25	25

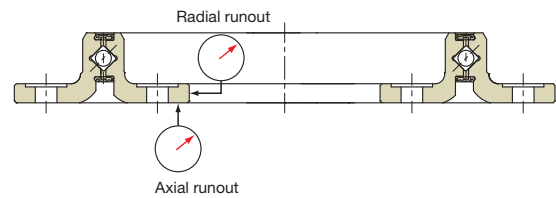
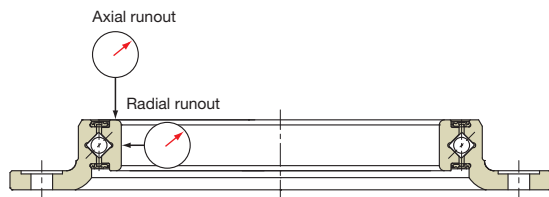

Dimensional Accuracy

Dimensional Tolerances of the Bearing Inner Diameter, Outer Diameter, and Width Unit: μm

Model No.	Tolerance of the bearing inner diameter			Tolerance of the bearing outer diameter			Tolerance of the bearing inner ring width			Tolerance of the bearing outer ring width		
	Diameter (mm)	Upper	Lower	Diameter (mm)	Upper	Lower	Width (mm)	Upper	Lower	Width (mm)	Upper	Lower
RF45	40	0	-12	70	0	-13	6	0	-120	8	-	-
RF57	50	0	-12	85	0	-15	8	0	-120	11	-	-
RF67	60	0	-15	95	0	-15	8	0	-120	11	-	-
RF77	70	0	-15	105	0	-15	8	0	-120	11	-	-
RF97	90	0	-20	125	0	-18	8	0	-120	11	-	-
RF127	120	0	-20	160	0	-25	8	0	-120	11	-	-

Dimensional Tolerances of the Bearing Inner Diameter, Outer Diameter, and Width Unit: μm

Model No.	Tolerance of the bearing inner diameter			Tolerance of the bearing outer diameter			Tolerance of the bearing inner ring width			Tolerance of the bearing outer ring width		
	Diameter (mm)	Upper	Lower	Diameter (mm)	Upper	Lower	Width (mm)	Upper	Lower	Width (mm)	Upper	Lower
RF45F	20	0	-10	70	0	-13	8	-	-	8	-	-
RF57F	30	0	-10	85	0	-15	11	-	-	11	-	-
RF67F	40	0	-12	95	0	-15	11	-	-	11	-	-
RF77F	45	0	-12	105	0	-15	11	-	-	11	-	-
RF97F	65	0	-15	125	0	-18	11	-	-	11	-	-
RF127F	95	0	-20	160	0	-25	11	-	-	11	-	-

Note) The tolerance of the bearing inner diameter and outer diameter is the arithmetic average of the maximum and minimum diameters obtained in measuring the bearing inner diameter at two points.

Note) The tolerance of the bearing outer diameter indicates the value before separation.

Lubrication

Standard Grease

AFB-LF Grease is a general-purpose grease that provides excellent extreme pressure resistance and mechanical stability through the use of a refined mineral oil base oil and a lithium-based consistency enhancer.

*Non-standard greases are also available. Contact THK for details.

AFB-LF Representative Physical Properties

Item	Representative physical property	Testing method
Consistency enhancer	Lithium-based	
Base oil	Refined mineral oil	
Base oil kinematic viscosity: mm ² /s (40°C)	170	JIS K 2220 23
Worked penetration (25°C, 60 W)	275	JIS K 2220 7
Mixing stability (100,000 W)	345	JIS K 2220 15
Dropping point: °C	193	JIS K 2220 8
Evaporation volume: mass% (99°C, 22 h)	0.4	JIS K 2220 10
Oil separation rate: mass% (100°C, 24 h)	0.6	JIS K 2220 11
Copper plate corrosion (B method, 100°C, 24 h)	Passed	JIS K 2220 9
Low-temperature torque: mN·m (-20°C)	Starting	130
	Rotational	51
4-ball testing (welding load): N	3089	ASTM D2596
Operating temperature range: °C	-15 to 100	
Color	Yellowish brown	

Model Number Coding

Select an option. *Specify each item for the models in the catalog.

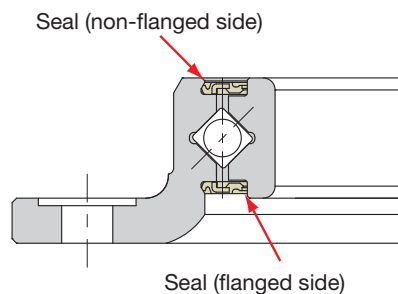
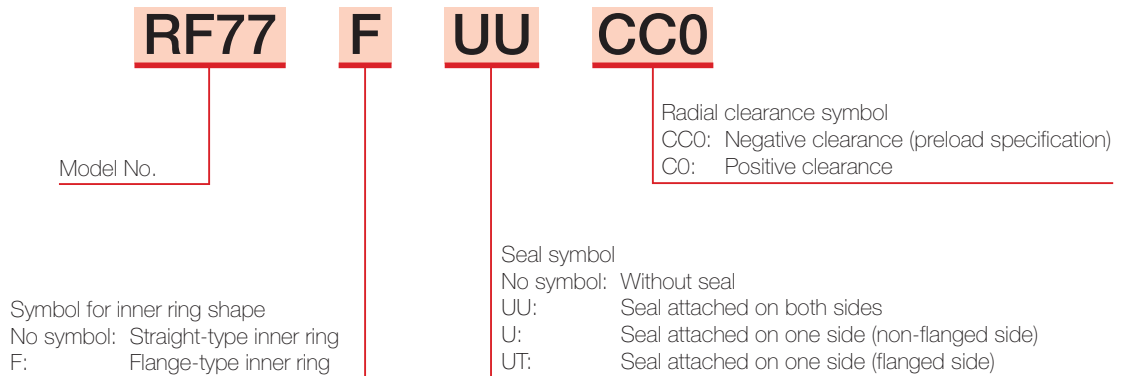

Specification Table

Straight-type inner ring

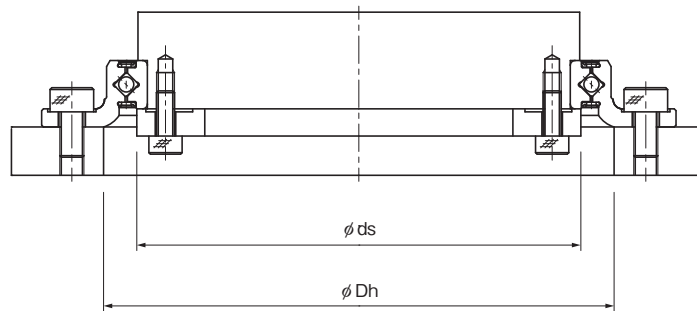
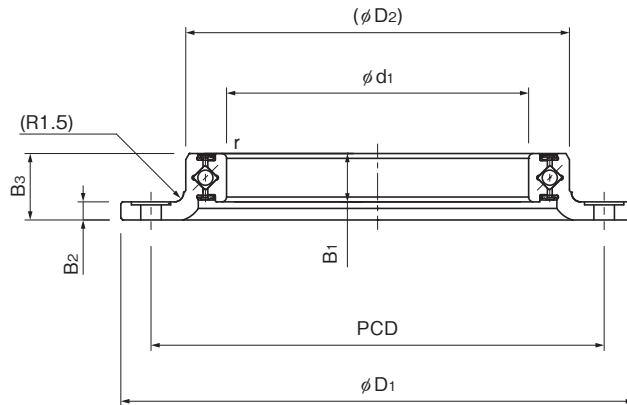
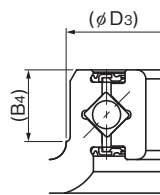

Unit: mm

Shaft diameter	Model No.	Main dimensions										Shoulder height		Permissible load	Mass (kg)
		Inner diameter		Outer diameter		Roller pitch circle diameter	Width					ds (max)	Dh (min)	Moment (N·m)	
		d ₁	D ₁	(D ₂)	(D ₃)	dp	B ₁	B ₂	B ₃	(B ₄)	r _{min}				
40	RF45	40	70	49	49.7	44.7	6	2.1	8	4	0.15	42.5	50.5	5.12	0.06
50	RF57	50	85	63.4	64.1	57	8	3	11	6	0.5	53.5	64.5	15.3	0.13
60	RF67	60	95	73.4	74.1	67	8	3	11	6	0.5	63.5	74.5	21.8	0.15
70	RF77	70	105	83.4	84.1	77	8	3	11	6	0.5	73.5	84.5	28.3	0.17
90	RF97	90	125	103.4	104.1	97	8	3	11	6	0.5	93.5	104.5	45.1	0.22
120	RF127	120	160	133.4	134.1	127	8	3	11	6	0.5	123.5	134.5	76.9	0.30

* The outer diameter indicates the value before separation.

* The shoulder height ϕds should be designed so that it is inside the raceway.

Unit: mm

Shaft diameter	Model No.	Mounting hole-related	
		Outer ring	
		PCD	Mounting hole
40	RF45	60	6- $\phi 3.4$ drilled through, $\phi 6.5$ counterbore depth 0.1
50	RF57	75	8- $\phi 3.4$ drilled through, $\phi 6.5$ counterbore depth 0.1
60	RF67	85	8- $\phi 3.4$ drilled through, $\phi 6.5$ counterbore depth 0.1
70	RF77	95	8- $\phi 4.5$ drilled through, $\phi 8$ counterbore depth 0.1
90	RF97	115	12- $\phi 4.5$ drilled through, $\phi 8$ counterbore depth 0.1
120	RF127	148	12- $\phi 5.5$ drilled through, $\phi 9.5$ counterbore depth 0.1

Flange-type inner ring

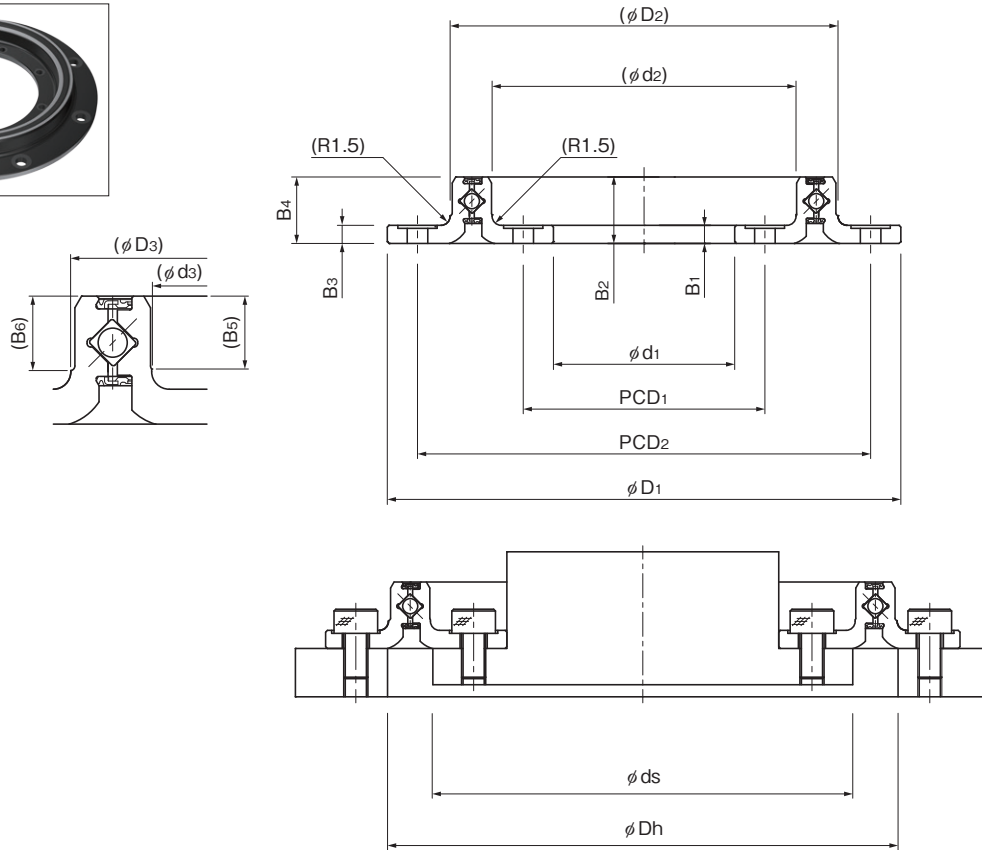

Unit: mm

Shaft diameter	Model No.	Main dimensions										Shoulder height		Permissible load	Mass (kg)
		Inner diameter			Outer diameter			Roller pitch circle diameter	Width			ds (max)	Dh (min)	Moment (N·m)	
		d ₁	(d ₂)	(d ₃)	D ₁	(D ₂)	(D ₃)	d _p	B ₁ , B ₃	B ₂ , B ₄	(B ₅ , B ₆)				
20	RF45F	20	40.4	40.1	70	49	49.7	44.7	2.1	8	4	39	50.5	5.12	0.08
30	RF57F	30	50.6	50.4	85	63.4	64.1	57	3	11	6	49.5	64.5	15.3	0.17
40	RF67F	40	60.6	60.4	95	73.4	74.1	67	3	11	6	59.5	74.5	21.8	0.20
45	RF77F	45	70.6	70.4	105	83.4	84.1	77	3	11	6	69.5	84.5	28.3	0.24
65	RF97F	65	90.6	90.4	125	103.4	104.1	97	3	11	6	89.5	104.5	45.1	0.30
95	RF127F	95	120.4	120.2	160	133.4	134.1	127	3	11	6	129.5	134.5	76.9	0.42

* The outer diameter indicates the value before separation.

Unit: mm

Shaft diameter	Model No.	Mounting hole-related			
		Inner ring		Outer ring	
		PCD ₁	Mounting hole	PCD ₂	Mounting hole
20	RF45F	30	6-φ3.4 drilled through, φ6.5 counterbore depth 0.1	60	6-φ3.4 drilled through, φ6.5 counterbore depth 0.1
30	RF57F	40	8-φ3.4 drilled through, φ6.5 counterbore depth 0.1	75	8-φ3.4 drilled through, φ6.5 counterbore depth 0.1
40	RF67F	50	8-φ3.4 drilled through, φ6.5 counterbore depth 0.1	85	8-φ3.4 drilled through, φ6.5 counterbore depth 0.1
45	RF77F	56	8-φ4.5 drilled through, φ8 counterbore depth 0.1	95	8-φ4.5 drilled through, φ8 counterbore depth 0.1
65	RF97F	76	12-φ4.5 drilled through, φ8 counterbore depth 0.1	115	12-φ4.5 drilled through, φ8 counterbore depth 0.1
95	RF127F	107	12-φ5.5 drilled through, φ9.5 counterbore depth 0.1	148	12-φ5.5 drilled through, φ9.5 counterbore depth 0.1

Notes

- The product does not have a greasing hole.
- The outer ring of this product was split to allow roller insertion. Pay attention to the mounting orientation so that the split section does not overlap with the area under the maximum load.
Fasten the bolts on the outer ring starting from the mounting holes to the right and left of the split section so that it will not open up.
Contact THK for details.

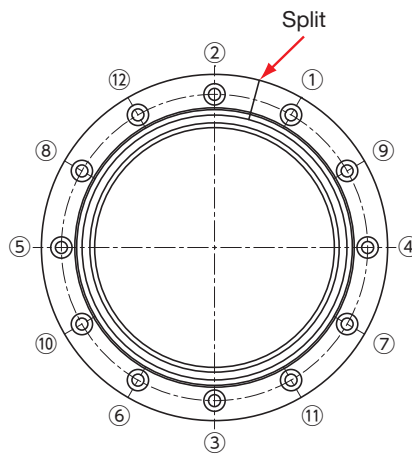

This catalog only describes the product's basic specifications.
Please contact THK if you are considering purchasing this product.

Handling

- (1) The improper installation of a spacer cage in a cross roller ring greatly impacts its rotational functionality. Please do not disassemble the cross roller ring.
- (2) Take care not to drop or strike the cross roller ring. Otherwise, it may cause injury or damage the unit. Even if there is no outward indication of damage, a sudden impact could prevent the unit from functioning properly.
- (3) Wear appropriate safety gear, such as protective gloves and safety shoes, when handling the product.

Precautions on Use

- (1) Prevent foreign materials, such as cutting chips or coolant, from entering the product. Failure to do so could damage the product.
- (2) Prevent foreign materials, such as cutting chips, coolant, corrosive solvents, or water from getting in the product by using a bellows or cover when the product is used in an environment where such a thing is likely.
- (3) Do not use this product if the external temperature exceeds 80°C. If used above this temperature, there is a risk that the resin and rubber parts may deform or become damaged.
- (4) Clean the product if foreign materials such as cutting chips adhere to the product.
- (5) Slight oscillations can inhibit the formation of an oil film between the raceways and the area of contact for the balls, resulting in fretting. We recommend periodically rotating the cross roller ring several times to help ensure that a film forms on the surfaces and rolling elements.
- (6) Please be aware that the cross roller ring seals are dust seals and may be unable to prevent the ingress of very fine particles and liquids.
- (7) Do not forcibly drive a pin, key, or any other positioning device into the product. This could create indentations on the raceways and impair the product's function.
- (8) When installing the cross roller ring to a housing, if the inner ring is fixed, hammer the inner ring to insert it. If the outer ring is fixed, hammer the outer ring. Hammering the non-fixed side may cause damage to the unit.
- (9) If the mounting material lacks sufficient rigidity or accuracy, the bearing load may be focused in one area, and bearing functionality will dramatically decrease. Therefore, carefully consider the rigidity and accuracy of the housing and base, and the strength of the securing bolts.
- (10) Be careful of the dimensional tolerances of the mounting components to ensure that the presser flange firmly holds the inner and outer rings from the sides. (Straight-type inner ring)

Lubrication

- (1) Do not mix different lubricants. Even grease containing the same type of thickening agent may, if mixed, interact negatively due to disparate additives or other ingredients.
- (2) When using the product in locations exposed to constant vibrations or in special environments such as in clean rooms, vacuums, and low/high temperatures, use a lubricant suitable for its use/environment.
- (3) Grease viscosity can vary depending on the temperature. Please keep in mind that the torque of the cross roller ring may be affected by changes in viscosity.
- (4) Excess grease may protrude from the outside edge of the cross roller ring. The structure of peripheral components will require careful consideration if contamination due to grease around the edges of the device is a concern.
- (5) When planning to use a special grease or a lubricant other than grease, please contact THK.

Storage

When storing the cross roller ring, pack it as designated by THK and store it indoors in a horizontal position away from high or low temperatures and high humidity.

Please note that after the product has been in storage for an extended period, the lubricant inside may have deteriorated.

Disposal

The product should be treated as industrial waste and disposed of appropriately.

Other Recommended Products

Cross Roller Ring

RAU

- Wide lineup includes super-small models.
The thin type (5 mm) is the smallest cross roller ring diameter.
- Lineup includes:
5 mm width thin type: ϕ 10 to ϕ 100 inner diameter
8 mm and 13 mm width: ϕ 50 to ϕ 200 inner diameter

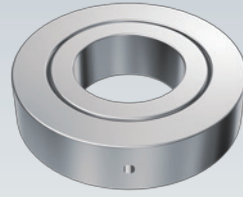

Cross Roller Ring

RU

- Easy to install
- Stable rotating accuracy and torque
- Lineup includes inner diameters from ϕ 20 to ϕ 350

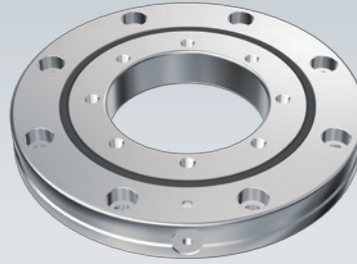

Cross Roller Ring for Robots RF

●“LM Guide” and “” are registered trademarks of THK CO., LTD.

- The actual products may differ from the pictures and photographs in this catalog.
- Outward appearances and specifications are subject to change without notice for the purpose of improvement. Please consult with THK before using.
- Although great care has been taken in the production of this catalog, THK will not take any responsibility for damage resulting from typographical errors or omissions.
- For exports of our products and technologies and sales for export, our basic policy is to comply with the Foreign Exchange and Foreign Trade Act and other laws and regulations. Please consult us in advance if you want to export our products by the piece.

All rights reserved

THK CO., LTD.

Headquarters 2-12-10 Shibaura, Minato-ku, Tokyo 108-8506 Japan

International Sales Department Phone: +81-3-5730-3860

www.thk.com
