

Controller series

Model: **TLC** Low-capacity servo driver controller

THC High-capacity servo driver controller

TNU Network unit





Chapter 5

TLC

5-001

THC

5-011

TNU

5-021

TLC

Servo driver controller for single axis



Features

Ready to use, simplified setup.

Simple Operation

Use PC setup tool D-Step or digital operator TDO to access many useful functions.

Functions

- Selectable function modes
(64-position, external unit input instruction, 256-position, 512-position, Solenoid mode 1, and Solenoid mode 2)
- Step data count: Up to 512 (depending on function mode)
- Alarm history: Up to 50 (including power ON history)
- Switching between Auto/Manual, brake release switch
- Selectable control methods (positioning or pressing)

Combined Control Device Model Configuration (TLC)

● Economy series

Control device model	Capacity	Power supply voltage	Type	Encoder type	Actuator model	Lead	Home position	Brake	Stroke
TLC	005	24DC	MOD	A	ES6	12	D	B	0050
(1) TLC	(2) 005: 50W	(3) 24DC: 24VDC	(4) MOD: Mode switching type	(5) A: Absolute	(6) Direct coupling ES5 ES6 EC4* Motor wrap ES5R ES6R EC4R	(7) 06: 6mm 12: 12mm	(8) D: Motor side R: Reverse motor side	(9) No symbol: Without brake B: With brake	(10) Enter the stroke of the actuator model (6) Example) 0050: 50mm

* Select "EC4" for EC4H.

● Compact series

Control device model	Capacity	Power supply voltage	Type	Encoder type	Actuator model	Lead	Home position	Brake	Stroke
TLC	005	24DC	MOD	A	KRF4	06	D	B	0050
(1) TLC	(2) 005: 50W	(3) 24DC: 24VDC	(4) MOD: Mode switching type	(5) A: Absolute	(6) KRF4 KRF5	(7) 06: 6mm 10: 10mm	(8) D: Motor side R: Reverse motor side	(9) No symbol: Without brake B: With brake	(10) Enter the stroke of the actuator model (6) Example) 0050: 50mm

● Universal series

Control device model	Capacity	Power supply voltage	Type	Encoder type	Actuator model	Lead	Home position	Brake	Stroke
TLC	005	24DC	MOD	A	US6T	12	D	B	0100
(1) TLC	(2) 005: 50W	(3) 24DC: 24VDC	(4) MOD: Mode switching type	(5) A: Absolute	(6) Direct coupling US6T Motor wrap US6RT	(7) 06: 6mm 12: 12mm	(8) D: Motor side R: Reverse motor side	(9) No symbol: Without brake B: With brake	(10) Enter the stroke of the actuator model (6) Example) 0100: 100mm

● Press series

Control device model	Capacity	Power supply voltage	Type	Encoder type	Actuator model	Lead	Home position	Brake	Stroke
TLC	005	24DC	MOD	A	PCT20	06N	D	B	0050
(1) TLC	(2) 005: 50W	(3) 24DC: 24VDC	(4) MOD: Mode switching type	(5) A: Absolute	(6) Direct coupling PCT20 Motor wrap PCT20R	(7) 06N	(8) D: Motor side R: Reverse motor side	(9) No symbol: Without brake B: With brake	(10) 0050: 50mm 0100: 100mm 0150: 150mm 0200: 200mm

ES/EC
KRF
US/USW
PCT/PC
Controller

TLC Specifications

ES/EC

KRF

US/USW

PCT/PC

Controller

Type of machine	Model		TLC					
	Capacity		50W					
Input power supply	Main circuit		24VDC±10%					
	Control circuit							
	Power supply [A]							Rated 6A (Max 16A)
Control	Control axis		Single axis					
	Motor		AC servo motor					
	Control		Feedback control (Semi-closed loop)					
	Position detection		Absolute					
	Acceleration/deceleration		Trapezoid acceleration, S-shape acceleration					
Program	Function mode		64-position	External unit input	256-position	512-position	Solenoid mode 1	Solenoid mode 2
	Step data count		64 points	64 points	256 points	512 points	7 points	3 points
	Data input/output		PC setup tool D-STEP or Digital operator TDO					
Input/output	Dedicated input/output	Input points	16 points (Start, Return to home position, Pause, Reset, Servo ON, Specify step number, etc.) *					
		Output points	16 points (Return to home position completed, In position, Servo ready, Alarm, Emergency stop status, etc.) *					
	Input/output power supply		24VDC ±10% (This should be prepared by yourself.)					
Communication	Serial communication	Device	Digital operator or PC software					
		Method	RS-485					
		Ports	Mini DIN × 1					
Usage conditions	Operating/storage temperature		0 to 40°C (No freezing) / -20 to 85°C (No freezing)					
	Operating/storage humidity		90% RH or below (No condensation)					
	Ambient condition		An indoor place (not exposed to direct sunlight) free from corrosive gas, flammable gas, oil mist, and dust, free from water, oil, and chemicals					
General specifications	Protective function		Overload, overvoltage, excessive position deviation, software limit over error, etc.					
	Accessories		Power supply connector × 1 I/O connector × 1					
	Options (sold separately)		Digital operator TDO (Cable length 5m) I/O cable 3m, 5m, 7m, and 10m Communication cable (Mini DIN→USB)					
	External dimensions [mm]		36.4mm (W)×199.2mm (H)×112.6mm (D)					
	Weight (not including battery)		0.4kg or less					

* This count varies depending on function mode.

System Configuration

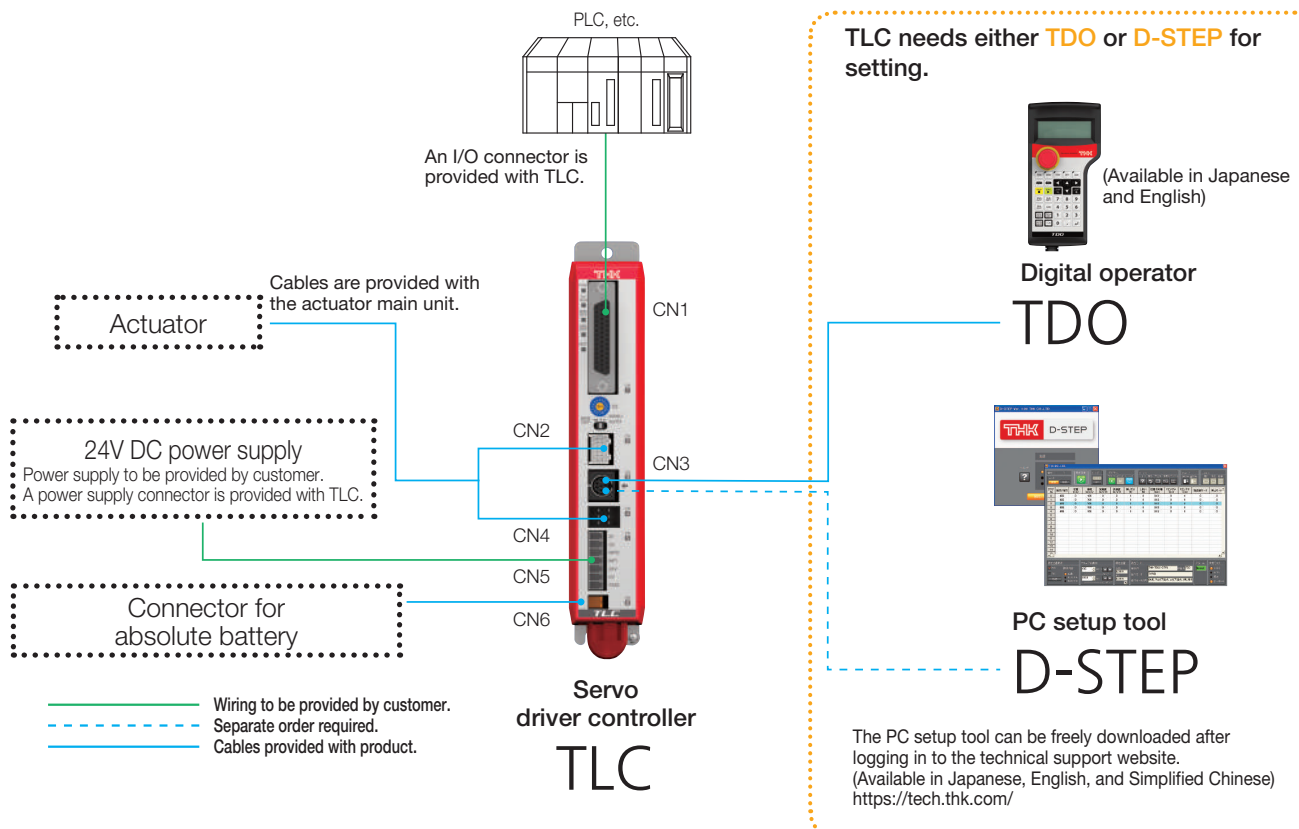

Controller

TLC (50W)

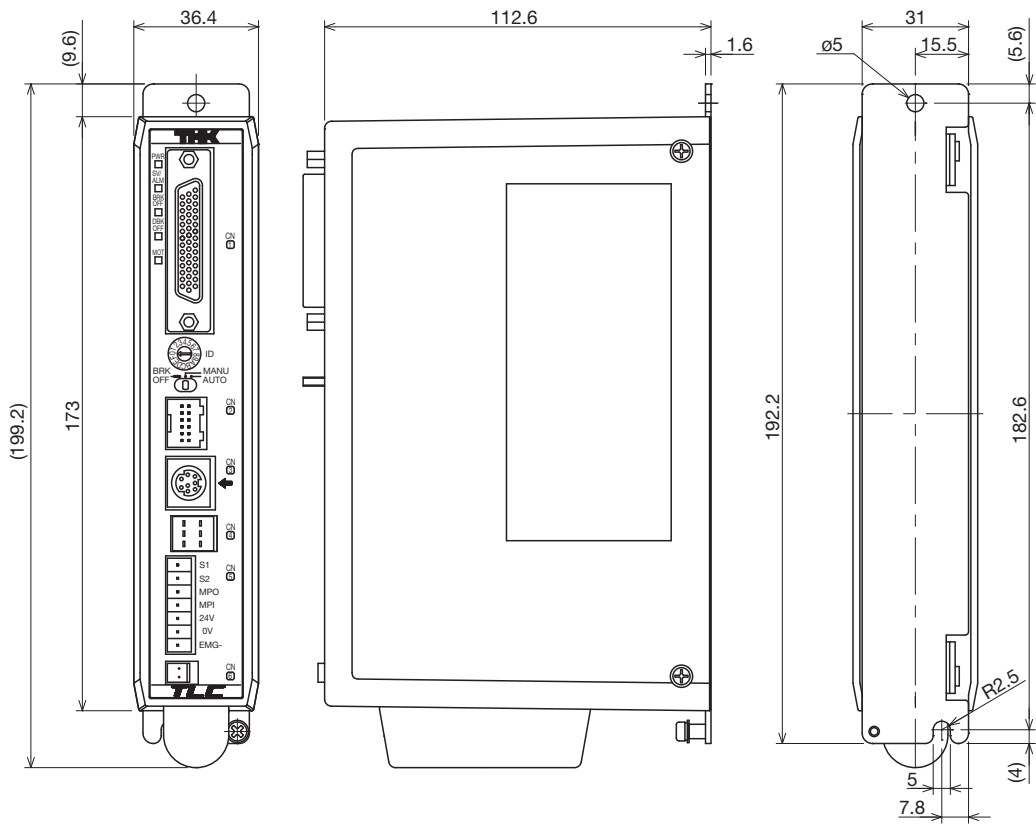

- ES/EC
- KRF
- US/USW
- PCT/PC
- Controller

TLC Pin Configuration

ES/EC
KRF
US/USW
PCT/PC
Controller

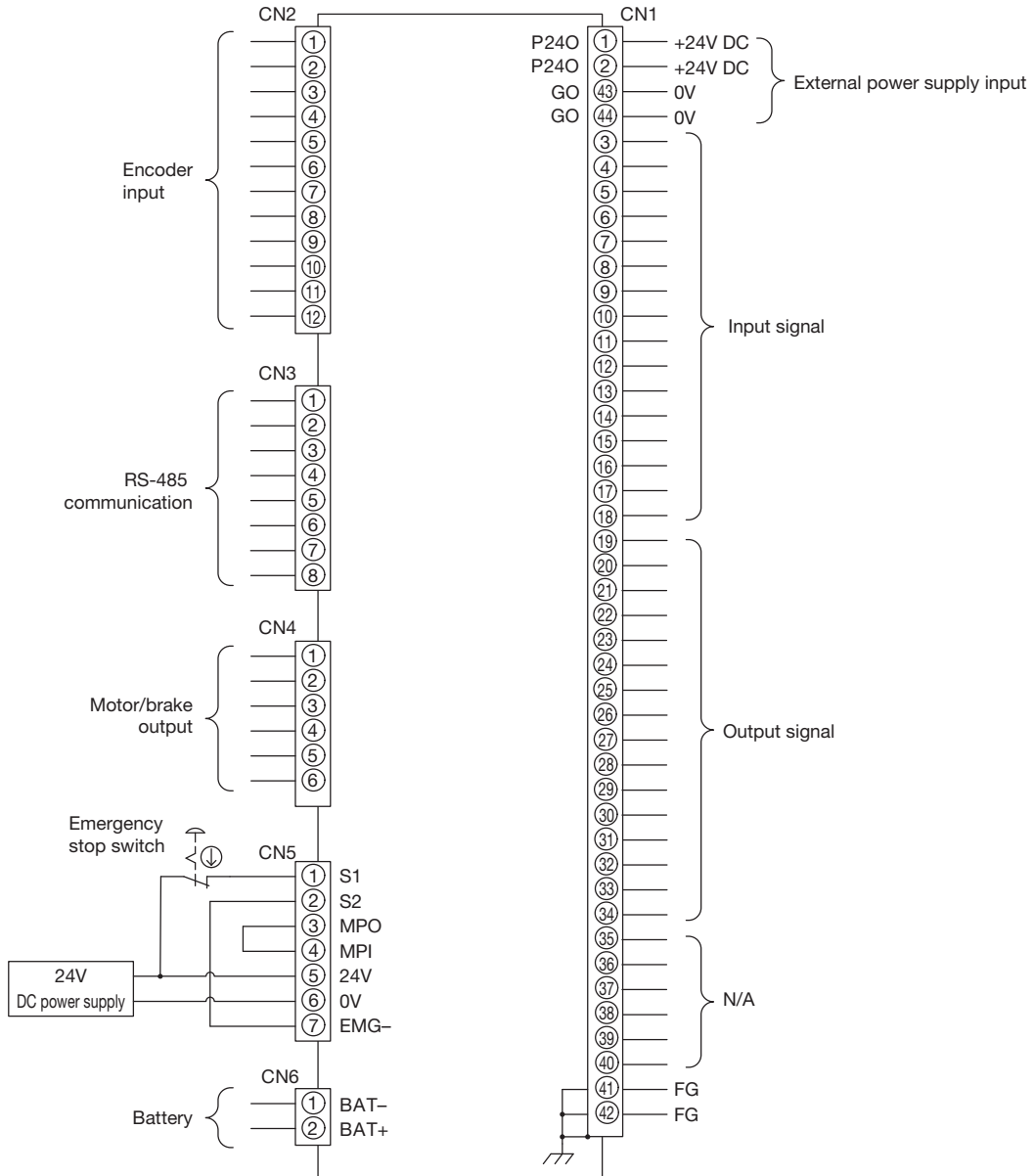

For attached I/O connector pin numbers, see P.5-009.
Customer provides 24V DC power supply for input/output circuitry.

Input/Output Circuitry for TLC (CN1)

Input circuit

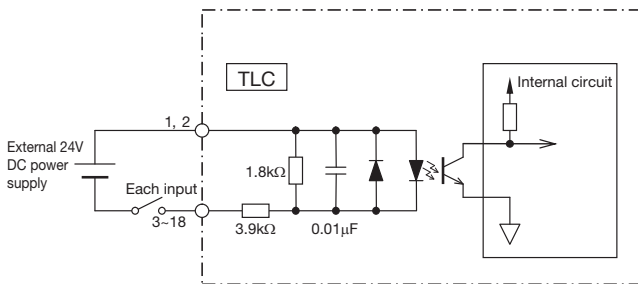

Output circuit

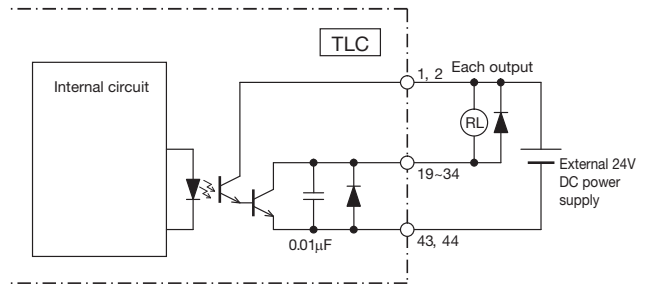

TLC Function Modes

TLC provides six modes to support various requirements and purposes.

Function mode		Overview	Step data count	Pressing operation
Multi-point positioning	0: 64-position	Multi-point positioning operation with 64 points With area output, with P area output	64	○
	1: External unit input instruction	Multi-point positioning operation with 64 points I/O-based external unit instruction mode Without area output, with P area output	64	-
	2: 256-position	Multi-point positioning operation with 256 points Without area output, with P area output	256	○
	3: 512-position	Multi-point positioning operation with 512 points Without area output, without P area output	512	○
Electromagnetic valve	4: Solenoid mode 1	Multi-point positioning operation with 7 points Direct move command input With area output, with P area output	7	○
	5: Solenoid mode 2	Multi-point positioning operation with 3 points Direct move command input With position sensor auto-switch output, area output and P area output	3	-

Pin Configuration by Function Mode

I/O	CN1 pin number	Signal name						
		Function mode 0 64-position	Function mode 1 External unit input	Function mode 2 256-position	Function mode 3 512-position	Function mode 4 Solenoid mode 1	Function mode 5 Solenoid mode 2	
Input	3	PI 0	PI 0	PI 0	PI 0	ST 0	ST 0	
	4	PI 1	PI 1	PI 1	PI 1	ST 1	ST 1	
	5	PI 2	PI 2	PI 2	PI 2	ST 2	ST 2	
	6	PI 3	PI 3	PI 3	PI 3	ST 3	-	
	7	PI 4	PI 4	PI 4	PI 4	ST 4	-	
	8	PI 5	PI 5	PI 5	PI 5	ST 5	-	
	9	-	MODE	PI 6	PI 6	ST 6	-	
	10	-	JOG/INCHING	PI 7	PI 7	-	-	
	11	-	JOG P	-	PI 8	-	-	
	12	BKRL	JOG N	BKRL	BKRL	BKRL	BKRL	
	13	STRT	STRT/PWRT	STRT	STRT	-	-	
	14	MANU	MANU	MANU	MANU	MANU	MANU	
	15	HOME	HOME	HOME	HOME	HOME	HOME	
	16	PAUSE	PAUSE	PAUSE	PAUSE	PAUSE	PAUSE	
	17	REST	REST	REST	REST	REST	REST	
	18	SV-ON	SV-ON	SV-ON	SV-ON	SV-ON	SV-ON	
	Output	19	PO 0	PO 0	PO 0	PO 0	PE 0	LS 0
		20	PO 1	PO 1	PO 1	PO 1	PE 1	LS 1
21		PO 2	PO 2	PO 2	PO 2	PE 2	LS 2	
22		PO 3	PO 3	PO 3	PO 3	PE 3	-	
23		PO 4	PO 4	PO 4	PO 4	PE 4	-	
24		PO 5	PO 5	PO 5	PO 5	PE 5	-	
25		MOVE	MOVE	PO 6	PO 6	PE 6	-	
26		AREA	MODES	PO 7	PO 7	AREA	AREA	
27		P AREA	P AREA	P AREA	PO 8	P AREA	P AREA	
28		MANU S	MANU S	MANU S	MANU S	MANU S	MANU S	
29		HEND	HEND	HEND	HEND	HEND	HEND	
30		INPS	INPS	INPS	INPS	INPS	-	
31		LOAD/TRQS	WEND	LOAD/TRQS	LOAD/TRQS	LOAD/TRQS	-	
32		SVRDY	SVRDY	SVRDY	SVRDY	SVRDY	SVRDY	
33		BALM	BALM	BALM	BALM	BALM	BALM	
34		ALM	ALM	ALM	ALM	ALM	ALM	

ES/EC

KRF

US/USW

PCT/PC

Controller

Input Signal Functions

Input		
Signal name	Description	Remarks
MANU	Operation mode	Switches AUTO/MANUAL from I/O. MANUAL when signal is on, and AUTO when it is off.
STRT	Start	Start signal of program step. Program starts when signal is on.
PI0 - PI8	Instruction position number	Input for specifying position numbers. Specifies programs at each signal level. Selects a program step and starts a program with "STRT" signal.
PAUSE	Pause	Temporarily interrupts the operation. PAUSE input status when signal is off. (N.C. connection specification)
HOME	Return to home position	Starts the return to home position operation. Returning to home position is started when signal is on. It stops when it is off.
SV-ON	Servo on	Turns the servo ON and OFF. Servo ON when signal is on, and servo OFF when signal is off.
REST	Alarm reset	Resets alarm. Resets remaining travel distance during pause. Resets when it is on.
BKRL	Brake release	Forcibly releases brake. Releases brake when it is on.
MODE	External unit input instruction mode	Enters the instruction mode when signal is on. Instruction mode when signal is on.
PWRT	Current position write with external unit input instruction	During the instruction mode, the position is written when this signal is greater than 20ms with the position for writing specified.
JOG/INCHING	Manual operation switch with external unit input instruction	Switching of manual operation during the instruction mode. Selects inching operation when it is on, and jog operation when it is off.
JOG P	Moving direction + with external unit input instruction	Operating direction and operation start signal during the instruction mode. Moves in + direction to the soft limit when signal is on. Decelerates and stops when it is off while moving.
JOG N	Moving direction - with external unit input instruction	Operating direction and operation start signal during the instruction mode. Moves in - direction to the soft limit when signal is on. Decelerates and stops when it is off while moving.
ST0 - 6	Cylinder type START	Program start signal for position numbers from ST0 to ST6. Can select either Level or Edge for signal using parameter 13 "move" command. Note that when more than two positions are on at the same time, the lowest-number signal takes precedence.

Output Signal Functions

Output		
Signal name	Description	Remarks
MANU S	Operation mode status	Operation mode status outputs (AUTO/MANUAL). MANUAL when signal is on, AUTO when off.
PO1 - PO8	End position number	Outputs the position number arrived after positioning is completed (binary outputs).
MOVE	Moving	Outputs signal during motor operation.
INPS	Positioning completed	Outputs when motor comes within the positioning completed width.
SVRDY	Operation preparations completed	Outputs signal when servo is on.
ALM	Alarm	Alarm output signal.
MODES	Operation mode status	Output signal for judging instruction mode or regular operation mode. Instruction mode when signal is on. Regular operation mode when it is off.
WEND	Writing completed	Signal is off after switching to the regular mode, and it is on for 30ms when writing of the PWRT signal is completed.
HEND	Return to home position completed	Outputs signal when returning to home position is completed.
AREA	Upper/lower area limit	On when the current position of actuator is within a range specified by the parameter.
P AREA	Position area	On when the current position of actuator is within a range specified by the program step.
EMGS	Emergency stop status	Outputs judgment for input of emergency stop. On during normal operation, and off when emergency stop circuit is shut off.
LOAD	Load output judgment status	On when a directive torque exceeds the threshold over a certain period within a judgment range.
TRQS	Torque level status	On when the load threshold is reached while moving. Off while the load remains under the threshold.
PE0 - PE6	Cylinder type arrival completed output	Signal generated after operation for position number is completed.
LS0 - LS2	Cylinder type position detection output	Outputs when the current position comes within the positioning width for each of the three points.

I/O Connector Pin Numbers

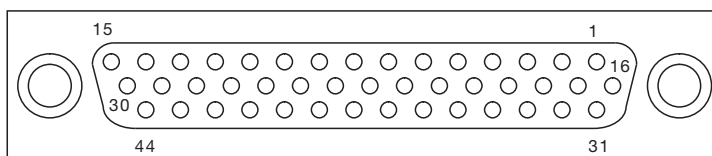

Controller connector port view

Actuator Cable

Motor brake cable for TLC: CBL-TLC-ACP-**F (Standard)

CBL-TLC-ACP-**R (High flex)

** indicates cable length: 03 (3m), 05 (5m), or 10 (10m).

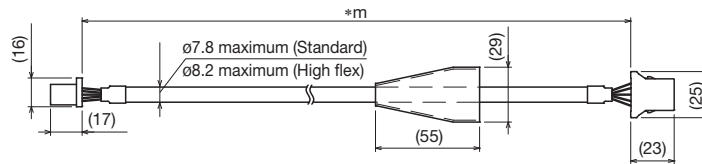

Encoder cable for TLC: CBL-TLC-ACS-**F (Standard)

CBL-TLC-ACS-**R (High flex)

** indicates cable length: 03 (3m), 05 (5m), or 10 (10m).

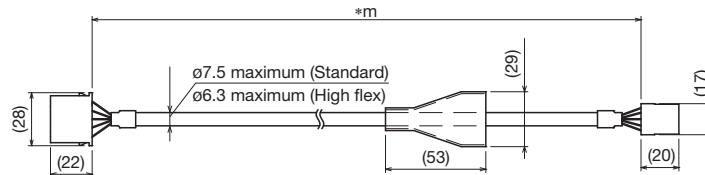

Motor brake extension cable for TLC/THC: CBL-ACP-EXT01-**F (Secured)

CBL-ACP-EXT01-**R (High flex)

** indicates cable length: 01 (1m), 03 (3m), or 05 (5m).

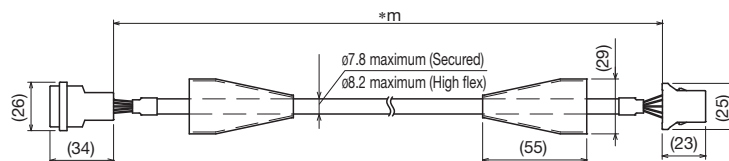

Extension encoder cable for TLC: CBL-ACS-EXT01-**F (Secured)

CBL-ACS-EXT01-**R (High flex)

** indicates cable length: 01 (1m), 03 (3m), or 05 (5m).

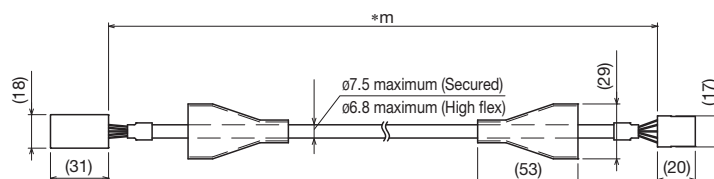

Note 1) For use involving moving elements, select high flex type. The recommended bending radius at the core of cable is R95 or greater.
(For use involving other than moving elements, R50 or greater is recommended.)

Note 2) When using the TLC servo driver controller, motor brake cable and encoder cable should be no longer than 11m.
Up to two extension cables can be connected.

ES/EC

KRF

US/USW

PCT/PC

Controller

Option

Lithium ion battery (for maintenance)

ER6V C4 (Toshiba Home Appliances Corporation)

- This is required for the absolute system.
- When replacing the battery, order the above.

ES/EC

KRF

US/USW

PCT/PC

Controller

High-capacity servo driver controller

THC

Servo driver controller for single axis



Features

Ready to use, simplified setup.

Simple Operation

Use PC setup tool D-Step or digital operator TDO to access many useful functions.

Functions

- Selectable function modes
(64-position, external unit input instruction, 256-position, 512-position, Solenoid mode 1, and Solenoid mode 2)
- Step data count: Up to 512 (depending on function mode)
- Alarm history: Up to 50 (including power ON history)
- Switching between Auto/Manual, brake release switch
- Selectable control methods (positioning or pressing)

ES/EC

KRF

US/USW

PCT/PC

Controller

Combined Control Device Model Configuration (THC)

● Compact series

Control device model	Capacity	Power supply voltage	Type	Encoder type	Actuator model	Lead	Home position	Brake	Stroke	Sensor
THC	010	100AC	MOD	A	KRF6	06	D	B	0050	1
(1) THC	(2) 010: 100W	(3) 100AC: 100VAC	(4) MOD: Mode switching type	(5) A: Absolute	(6) KRF6	(7) 06: 6mm 10: 10mm	(8) D: Motor side R: Reverse motor side	(9) No symbol: Without brake B: With brake	(10) Enter the stroke of the actuator model (6) Example) 0050: 50m	(11) No symbol: None 1: Sensor

● Universal series

Control device model	Capacity	Power supply voltage	Type	Encoder type	Actuator model	Lead	Home position	Brake	Stroke	Sensor
THC	020	100AC	MOD	A	USW12T	10	D	B	0100	1
(1) THC	(2) 010: 100W 020: 200W 040: 400W 075: 750W	(3) 100AC: 100VAC 200AC: 200VAC	(4) MOD: Mode switching type	(5) A: Absolute	(6) Direct coupling US6T US8T USW12T USW16T USW20T Motor wrap US6RT US8RT USW12RT USW16RT USW20RT	(7) 05: 5mm 06: 6mm 10: 10mm 12: 12mm 20: 20mm 30: 30mm 40: 40mm	(8) D: Motor side R: Reverse motor side	(9) No symbol: Without brake B: With brake	(10) Enter the stroke of the actuator model (6) Example) 0100: 100m	(11) No symbol: None 1: Standard sensor (Symbol P,Q) 2: Other sensor (Symbol 6,E)
	When the capacity is 750W, you only can select 200V AC.									
	When using motor rated output of 150W, select the capacity 020.									

● Press series

Control device model	Capacity	Power supply voltage	Type	Encoder type	Actuator model	Lead	Home position	Brake	Stroke
THC	010	100AC	MOD	A	PCT25	04N	D	B	0050
(1) THC	(2) 010: 100W 020: 200W 040: 400W 075: 750W	(3) 100AC: 100VAC 200AC: 200VAC	(4) MOD: Mode switching type	(5) A: Absolute	(6) Direct coupling PCT25 Motor wrap PCT25R PC30 PC40	(7) 04N 06N 06A 06B	(8) D: Motor side R: Reverse motor side	(9) No symbol: Without brake B: With brake	(10) Enter the stroke of the actuator model (6) Example) 0100: 100m

ES/EC

KRF

US/USW

PCT/PC

Controller

THC Specifications

Type of machine	Model		THC					
			100V AC			200V AC		
	Capacity		100W	200W	400W	100W	200W	400W
Input power supply	Main circuit		100V AC single-phase, 50/60Hz (Permissible voltage: 90 to 120V)			200V AC single-phase, 50/60Hz (Permissible voltage: 170 to 250V)		
	Control circuit		100V AC single-phase, 50/60Hz (Permissible voltage: 90 to 120V)			200V AC single-phase, 50/60Hz (Permissible voltage: 170 to 250V)		
	Power supply [A]		0.5	0.9	1.3	0.5	0.9	1.6
Control	Control axis		Single axis					
	Motor		AC servo motor					
	Control		Feedback control (Semi-closed loop)					
	Position detection		Absolute					
	Acceleration/deceleration		Trapezoid acceleration, S-shape acceleration					
Program	Function mode		64-position	External unit input	256-position	512-position	Solenoid mode 1	Solenoid mode 2
	Step data count		64 points	64 points	256 points	512 points	7 points	3 points
	Data input/output		PC setup tool D-STEP or Digital operator TDO					
Input/output	Dedicated input/output	Input points	16 points (Start, Return to home position, Pause, Reset, Servo ON, Specify step number, etc.) *					
		Output points	16 points (Return to home position completed, In position, Servo ready, Alarm, Emergency stop status, etc.) *					
	Input/output power supply		24VDC ±10% (This should be prepared by yourself.)					
Communication	Serial communication	Device Method	Digital operator or PC software					
		Ports	RS-485					
			Mini DIN × 1					
Usage conditions	Operating/storage temperature		0 to 40°C (No freezing)/-20 to 85°C (No freezing)					
	Operating/storage humidity		90% RH or below (No condensation)					
	Ambient condition		An indoor place (not exposed to direct sunlight) free from corrosive gas, flammable gas, oil mist, and dust, free from water, oil, and chemicals					
General specifications	Protective function		Overload, overvoltage, excessive position deviation, software limit over error, etc.					
	Accessories		Power supply connector × 1 I/O connector × 1					
	Options (sold separately)		Digital operator TDO (Cable length 5m) I/O cable 3m, 5m, 7m, and 10m Communication cable (Mini DIN↔USB)					
	External dimensions [mm]		200W or lower: 58mm (W) × 208.6mm (H) × 120mm (D) 400W or lower: 67.5mm (W) × 208.6mm (H) × 120mm (D)					
	Weight (not including battery)		1.3kg or less	1.3kg or less	1.3kg or less	1.3kg or less	1.3kg or less	1.3kg or less

* This count varies depending on function mode.

ES/EC
KRF
US/USW
PCT/PC
Controller

System Configuration

THC needs either **TDO** or **D-STEP** for setting.



(Available in Japanese and English)

Digital operator
TDO



PC setup tool
D-STEP

The PC setup tool can be freely downloaded after logging in to the technical support website.
(Available in Japanese, English, and Simplified Chinese)
<https://tech.thk.com/>

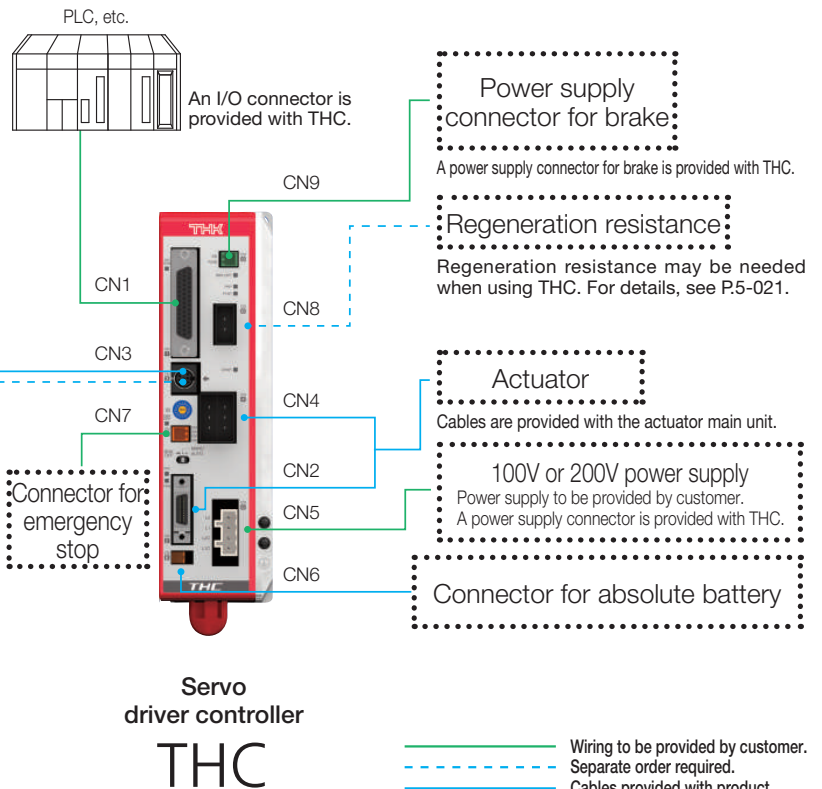

Controller

ES/EC
KRF
US/USW
PCT/PC
Controller

THC (100–200W)

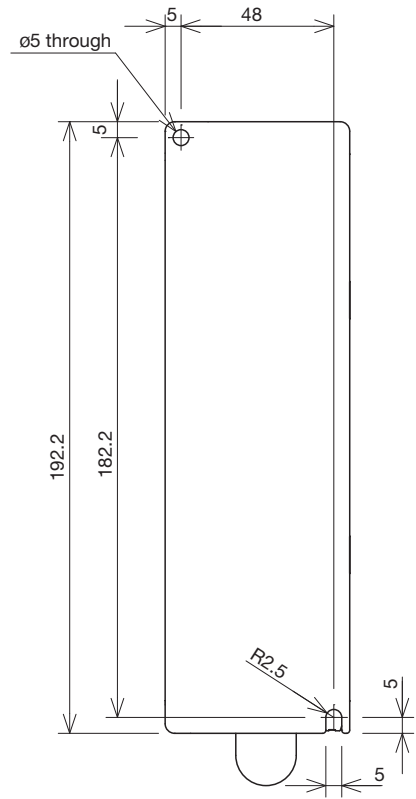
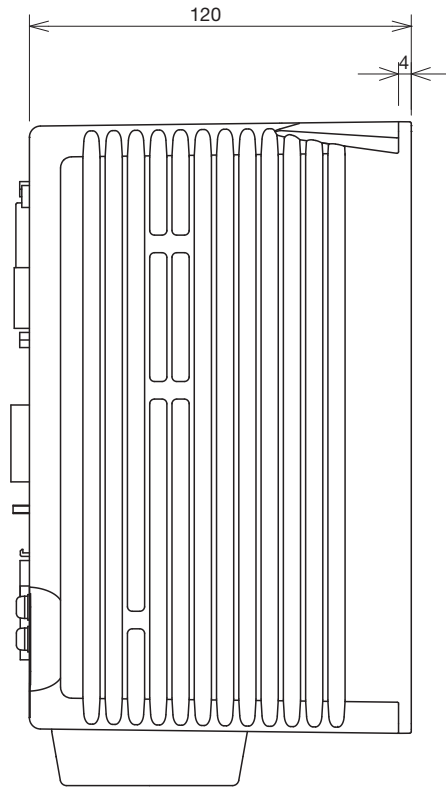
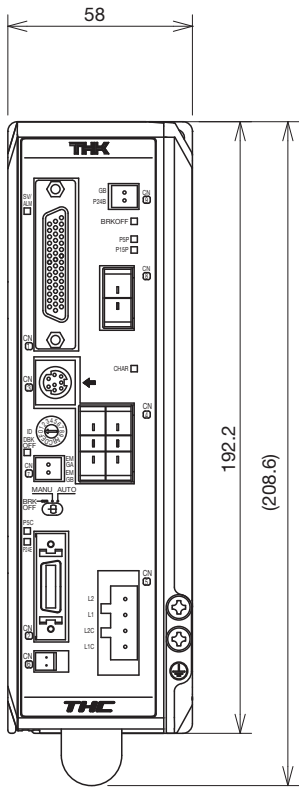

THC (400W & 750W)

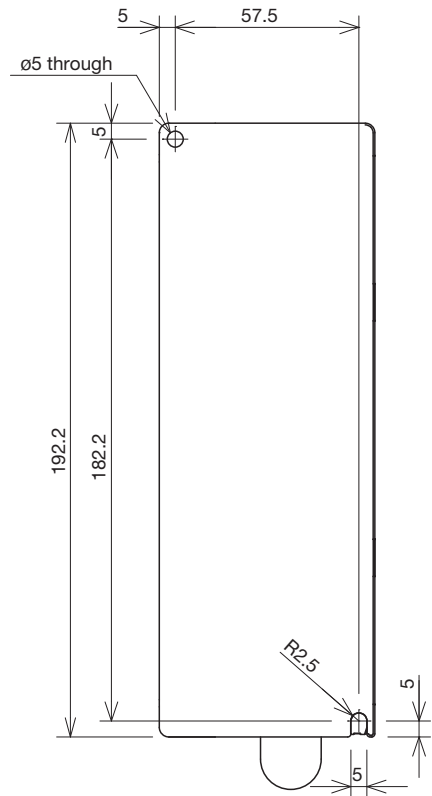
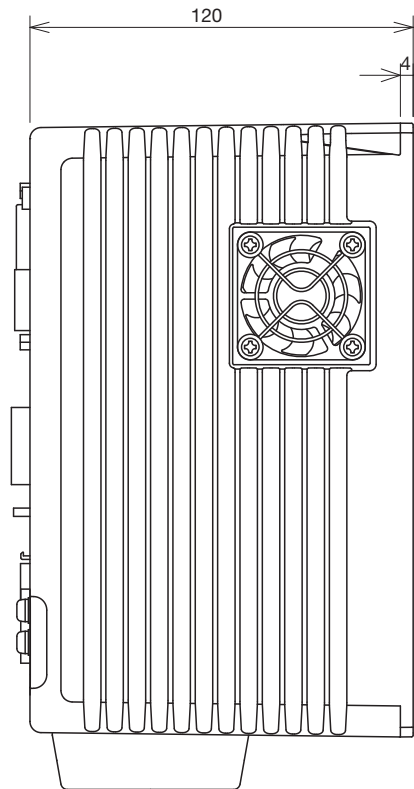
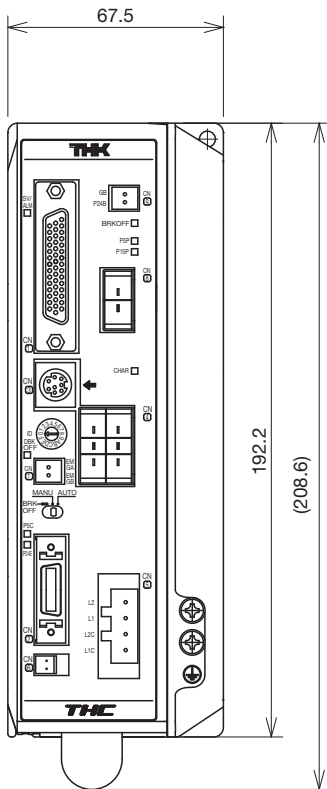

THC Pin Configuration

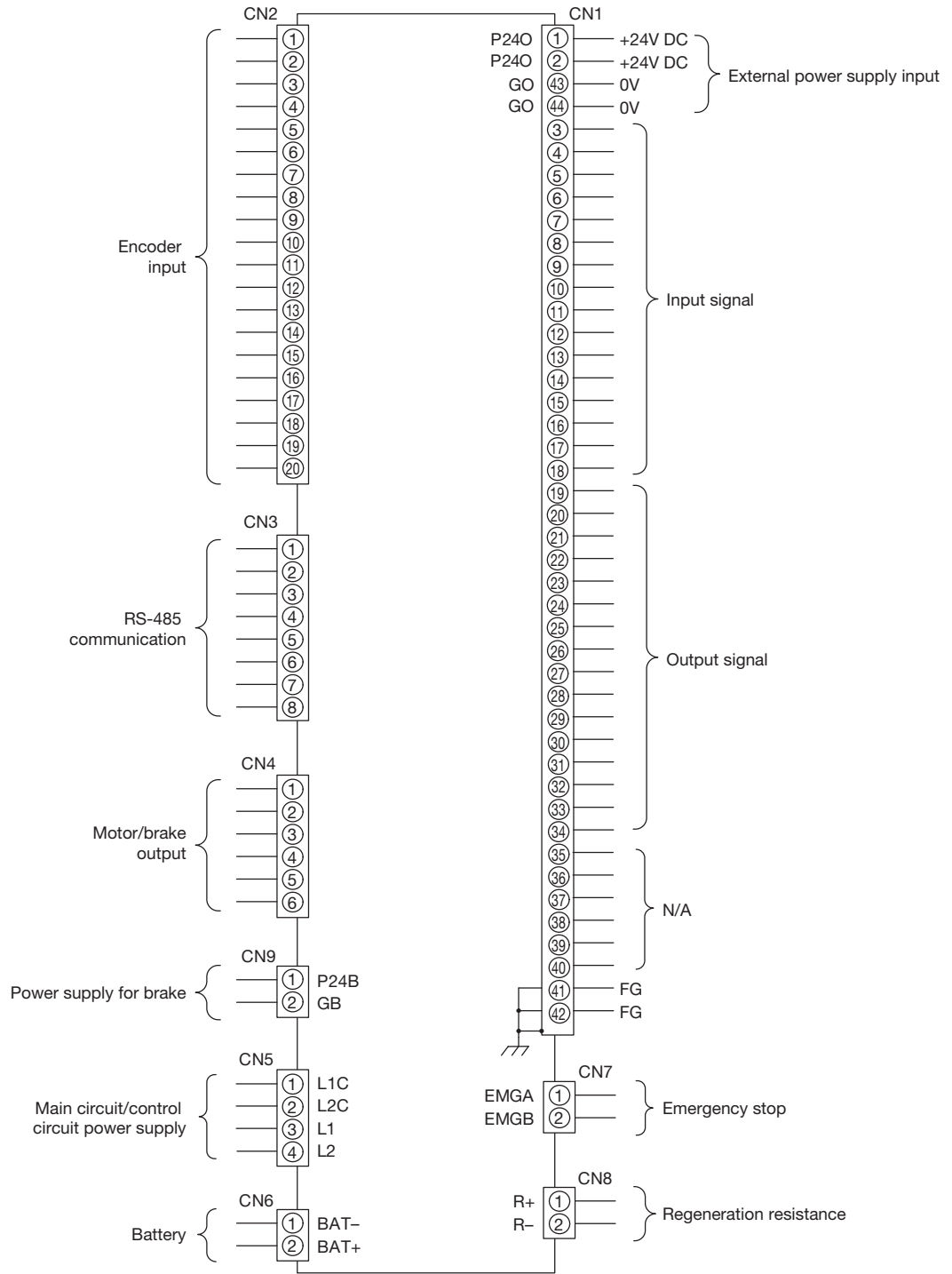

For attached I/O connector pin numbers, see P.5-018.
Customer provides 24V DC power supply for input/output circuitry.

Input/Output Circuitry for THC (CN1)

Input circuit

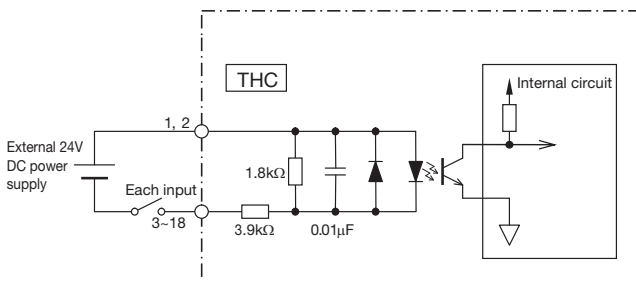

Output circuit

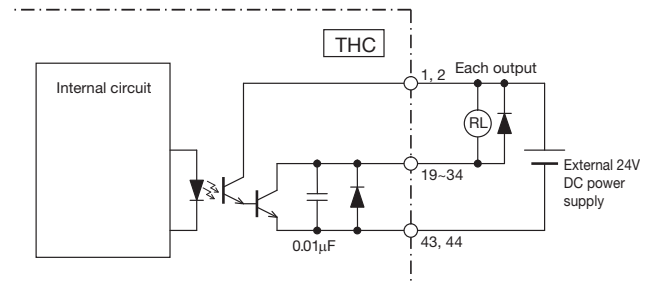

THC Function Modes

THC provides six modes to support various requirements and purposes.

Function mode		Overview	Step data count	Pressing operation
Multi-point positioning	0: 64-position	Multi-point positioning operation with 64 points With area output, with P area output	64	○
	1: External unit input instruction	Multi-point positioning operation with 64 points I/O-based external unit instruction mode Without area output, with P area output	64	-
	2: 256-position	Multi-point positioning operation with 256 points Without area output, with P area output	256	○
	3: 512-position	Multi-point positioning operation with 512 points Without area output, without P area output	512	○
Electromagnetic valve	4: Solenoid mode 1	Multi-point positioning operation with 7 points Direct move command input With area output, with P area output	7	○
	5: Solenoid mode 2	Multi-point positioning operation with 3 points Direct move command input With position sensor auto-switch output, area output and P area output	3	-

Pin Configuration by Function Mode

I/O	CN1 pin number	Signal name						
		Function mode 0 64-position	Function mode 1 External unit input	Function mode 2 256-position	Function mode 3 512-position	Function mode 4 Solenoid mode 1	Function mode 5 Solenoid mode 2	
Input	3	PI 0	PI 0	PI 0	PI 0	ST 0	ST 0	
	4	PI 1	PI 1	PI 1	PI 1	ST 1	ST 1	
	5	PI 2	PI 2	PI 2	PI 2	ST 2	ST 2	
	6	PI 3	PI 3	PI 3	PI 3	ST 3	-	
	7	PI 4	PI 4	PI 4	PI 4	ST 4	-	
	8	PI 5	PI 5	PI 5	PI 5	ST 5	-	
	9	-	MODE	PI 6	PI 6	ST 6	-	
	10	-	JOG/INCHING	PI 7	PI 7	-	-	
	11	-	JOG P	-	PI 8	-	-	
	12	BKRL	JOG N	BKRL	BKRL	BKRL	BKRL	
	13	STRT	STRT/PWRT	STRT	STRT	-	-	
	14	MANU	MANU	MANU	MANU	MANU	MANU	
	15	HOME	HOME	HOME	HOME	HOME	HOME	
	16	PAUSE	PAUSE	PAUSE	PAUSE	PAUSE	PAUSE	
	17	REST	REST	REST	REST	REST	REST	
	18	SV-ON	SV-ON	SV-ON	SV-ON	SV-ON	SV-ON	
	Output	19	PO 0	PO 0	PO 0	PO 0	PE 0	LS 0
		20	PO 1	PO 1	PO 1	PO 1	PE 1	LS 1
21		PO 2	PO 2	PO 2	PO 2	PE 2	LS 2	
22		PO 3	PO 3	PO 3	PO 3	PE 3	-	
23		PO 4	PO 4	PO 4	PO 4	PE 4	-	
24		PO 5	PO 5	PO 5	PO 5	PE 5	-	
25		MOVE	MOVE	PO 6	PO 6	PE 6	-	
26		AREA	MODES	PO 7	PO 7	AREA	AREA	
27		P AREA	P AREA	P AREA	PO 8	P AREA	P AREA	
28		MANU S	MANU S	MANU S	MANU S	MANU S	MANU S	
29		HEND	HEND	HEND	HEND	HEND	HEND	
30		INPS	INPS	INPS	INPS	INPS	-	
31		LOAD/TRQS	WEND	LOAD/TRQS	LOAD/TRQS	LOAD/TRQS	-	
32		SVRDY	SVRDY	SVRDY	SVRDY	SVRDY	SVRDY	
33		BALM	BALM	BALM	BALM	BALM	BALM	
34		ALM	ALM	ALM	ALM	ALM	ALM	

Input Signal Functions

Input		
Signal name	Description	Remarks
MANU	Operation mode	Switches AUTO/MANUAL from I/O. MANUAL when signal is on, and AUTO when it is off.
STRT	Start	Start signal of program step. Program starts when signal is on.
PI0 - PI8	Instruction position number	Input for specifying position numbers. Specifies programs at each signal level. Selects a program step and starts a program with "STRT" signal.
PAUSE	Pause	Temporarily interrupts the operation. PAUSE input status when signal is off. (N.C. connection specification)
HOME	Return to home position	Starts the return to home position operation. Returning to home position is started when signal is on. It stops when it is off.
SV-ON	Servo on	Turns the servo ON and OFF. Servo ON when signal is on, and servo OFF when signal is off.
REST	Alarm reset	Resets alarm. Resets remaining travel distance during pause. Resets when it is on.
BKRL	Brake release	Forcibly releases brake. Releases brake when it is on.
MODE	External unit input instruction mode	Enters the instruction mode when signal is on. Instruction mode when signal is on.
PWRT	Current position write with external unit input instruction	During the instruction mode, the position is written when this signal is greater than 20ms with the position for writing specified.
JOG/INCHING	Manual operation switch with external unit input instruction	Switching of manual operation during the instruction mode. Selects inching operation when it is on, and jog operation when it is off.
JOG P	Moving direction + with external unit input instruction	Operating direction and operation start signal during the instruction mode. Moves in + direction to the soft limit when signal is on. Decelerates and stops when it is off while moving.
JOG N	Moving direction - with external unit input instruction	Operating direction and operation start signal during the instruction mode. Moves in - direction to the soft limit when signal is on. Decelerates and stops when it is off while moving.
ST0 - 6	Cylinder type START	Program start signal for position numbers from ST0 to ST6. Can select either Level or Edge for signal using parameter 13 "move" command. Note that when more than two positions are on at the same time, the lowest-number signal takes precedence.

ES/EC

KRF

US/USW

PCT/PC

Controller

Output Signal Functions

Output		
Signal name	Description	Remarks
MANU S	Operation mode status	Operation mode status outputs (AUTO/MANUAL). MANUAL when signal is on, AUTO when off.
PO1 - PO8	End position number	Outputs the position number arrived after positioning is completed (binary outputs).
MOVE	Moving	Outputs signal during motor operation.
INPS	Positioning completed	Outputs when motor comes within the positioning completed width.
SVRDY	Operation preparations completed	Outputs signal when servo is on.
ALM	Alarm	Alarm output signal.
MODES	Operation mode status	Output signal for judging instruction mode or regular operation mode. Instruction mode when signal is on. Regular operation mode when it is off.
WEND	Writing completed	Signal is off after switching to the regular mode, and it is on for 30ms when writing of the PWRT signal is completed.
HEND	Return to home position completed	Outputs signal when returning to home position is completed.
AREA	Upper/lower area limit	On when the current position of actuator is within a range specified by the parameter.
P AREA	Position area	On when the current position of actuator is within a range specified by the program step.
EMGS	Emergency stop status	Outputs judgment for input of emergency stop. On during normal operation, and off when emergency stop circuit is shut off.
LOAD	Load output judgment status	On when a directive torque exceeds the threshold over a certain period within a judgment range.
TRQS	Torque level status	On when the load threshold is reached while moving. Off while the load remains under the threshold.
PE0 - PE6	Cylinder type arrival completed output	Signal generated after operation for position number is completed.
LS0 - LS2	Cylinder type position detection output	Outputs when the current position comes within the positioning width for each of the three points.

I/O Connector Pin Numbers

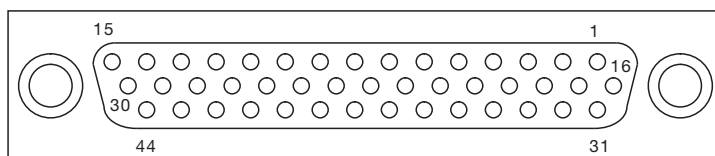

Controller connector port view

Actuator Cable

ES/EC

Motor brake cable for THC: CBL-THC-ACP-***F (Standard)

CBL-THC-ACP-***R (High flex)

** indicates cable length: 03 (3m), 05 (5m), or 10 (10m).

KRF

US/USW

PCT/PC

Controller

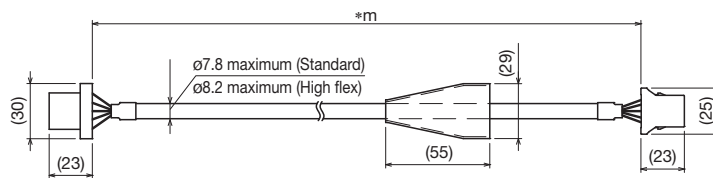

Encoder sensor cable for THC: CBL-THC-ACS-***F (Standard)

CBL-THC-ACS-***R (High flex)

** indicates cable length: 03 (3m), 05 (5m), or 10 (10m).

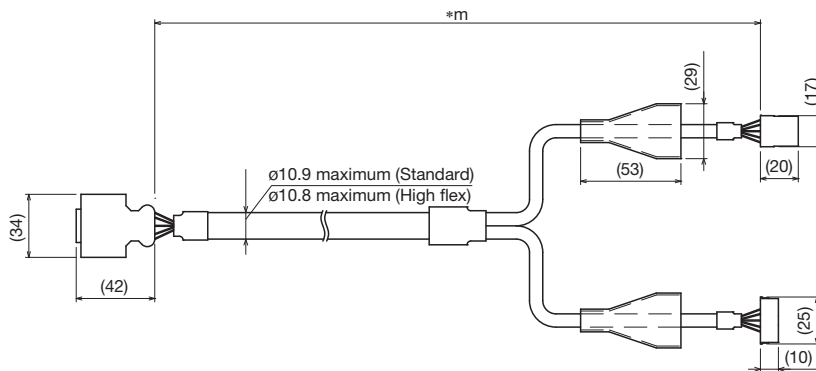

Motor brake extension cable for TLC/THC: CBL-ACP-EXT01-***F (Secured)

CBL-ACP-EXT01-***R (High flex)

** indicates cable length: 01 (1m), 03 (3m), or 05 (5m).

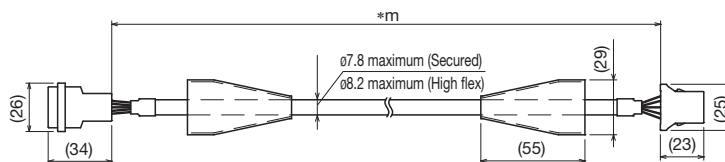

Encoder sensor extension cable for THC: CBL-ACS-EXT02-**F (Secured)

CBL-ACS-EXT02-**R (High flex)

** indicates cable length: 01 (1m), 03 (3m), or 05 (5m).

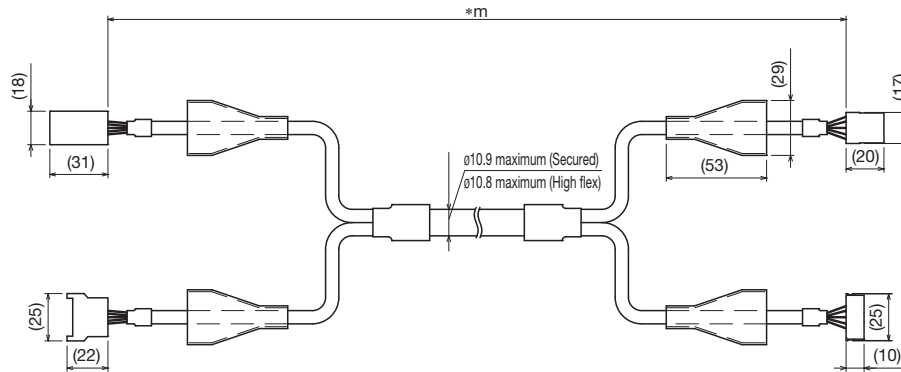

Note 1) For use involving moving elements, select high flex type. The recommended bending radius at the core of cable is R95 or greater.
(For use involving other than moving elements, R50 or greater is recommended.)

Note 2) When using the THC servo driver controller, motor brake cable and encoder sensor cable should be no longer than 16m.
Up to two extension cables can be connected.

Option

Lithium ion battery (for maintenance)

ER6V C4 (Toshiba Home Appliances Corporation)

- This is required for the absolute system.
- When replacing the battery, order the above.

Optional (Regeneration Resistance)

Regeneration resistance

To make electrical actuator operate via the THC controller series, a regeneration resistance may be necessary depending on the operating conditions. The following table lists the required number of regeneration resistances just for reference. The customer should provide the required number of them.

It is recommended that you use regeneration resistances manufactured by Iwaki Musen Kenkyusho Co.,LTD.

THK supplies regeneration resistance connection cables. The customer can order them separately as necessary.

■ Regeneration resistance (Power-type cement resistor)

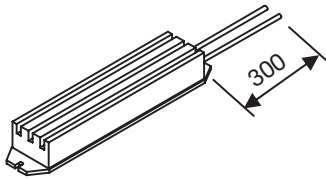

■ Regeneration resistance connection cable (CBL-REG00-01F)

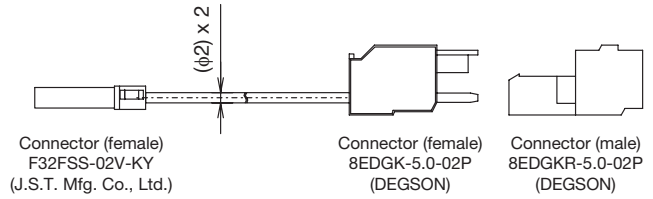

* Cable insertion jig (DG010-01P-19-00AH) is provided. (The customer does not have to provide special tools)

	Name of item	Manufacturer
A	RH150 100Ω J	Iwaki Musen
B	RH150 50Ω J	Kenkyusho Co.,LTD.

	Model	Length	Manufacturer
1	CBL-REG00-01F	1m	THK Co., Ltd.

THC capacity	Orientation	
	Horizontal mount	Vertical mount
100W	A x 1	A x 1
200W	A x 1	A x 1
400W	B x 2	B x 2
750W	B x 2	B x 2

Configuration Diagram

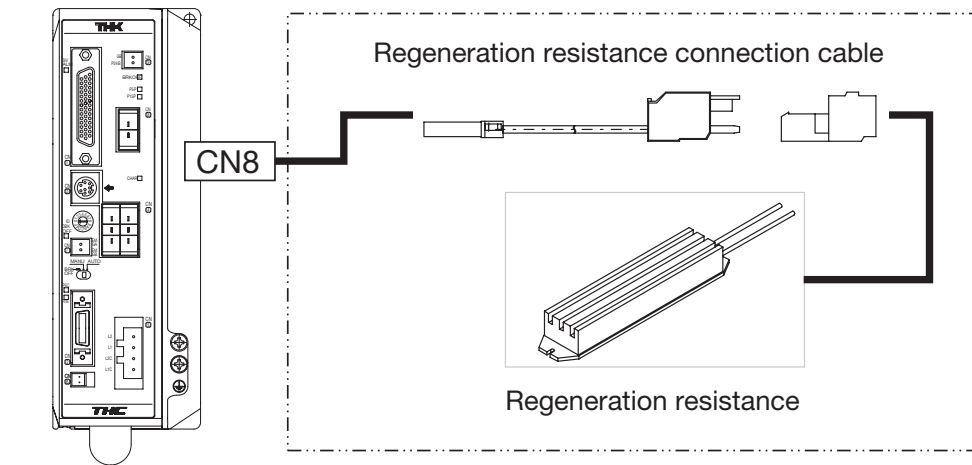

Controller series THC

* There is no polarity in wiring.

Regeneration Resistance External Drawing

RH150 (90W, 100Ω) (90W, 50Ω) common to all

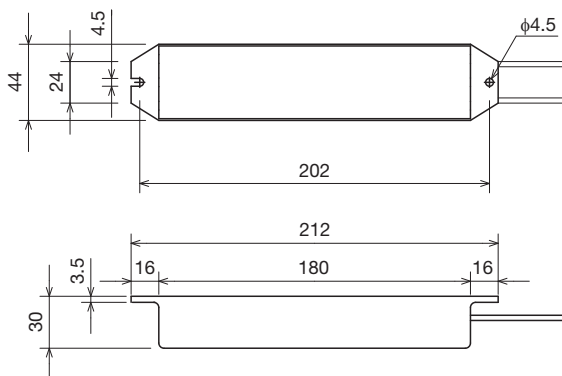

Wiring Example (Using Two Regeneration Resistances)

When you use two regeneration resistances, connect them in series.

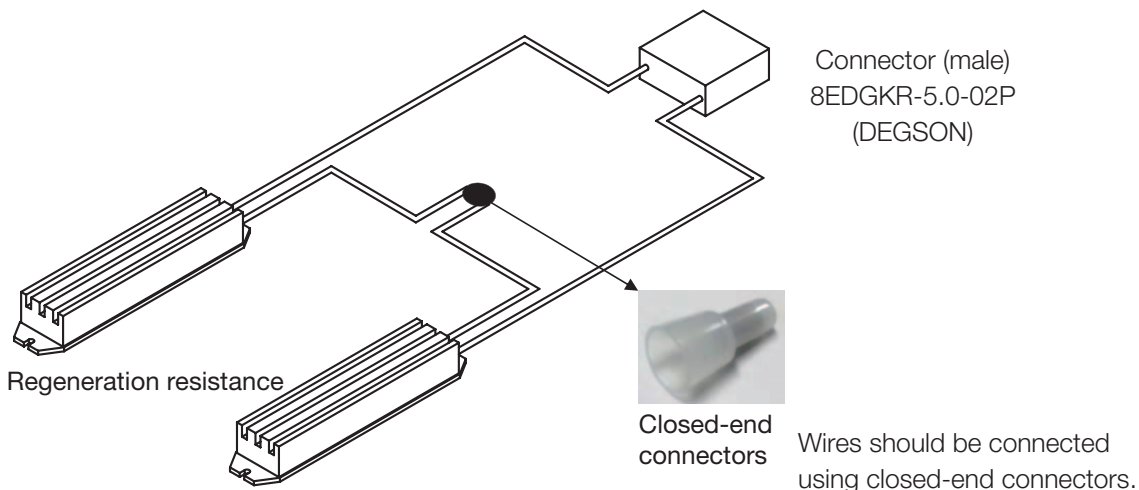

Precautions on Selecting Resistance

The customer should provide the required number of regeneration resistances for each THC.

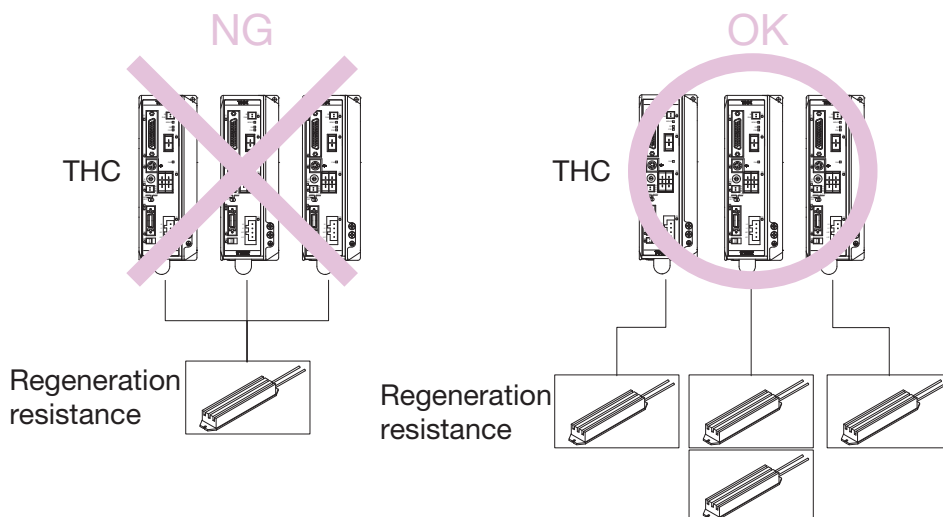

TNU



Fieldbus-compatible multiple-axis connection

Less Wiring Required

Connecting to a PLC through a fieldbus network requires less wiring than an I/O cable connection. In addition, the network unit and each driver controller can be connected with a single dedicated cable.

Up to 16 Axes Can Be Connected

Up to 16 axes of mixed THK driver controllers (TLC, and THC) can be connected using one TNU and TJU (branch unit) in combination.

System Configuration

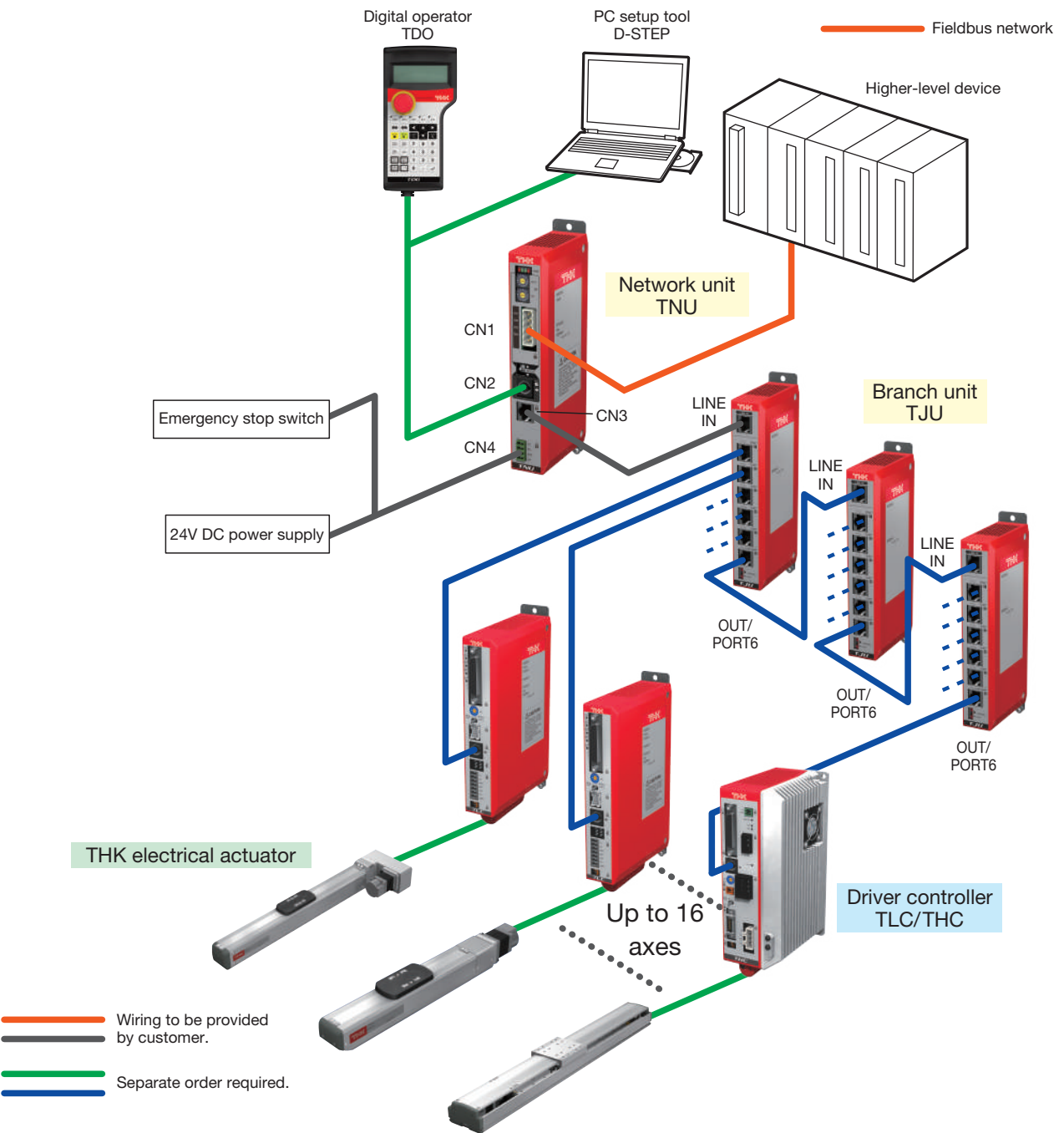

- ES/EC
- KRF
- US/USW
- PCT/PC
- Controller

Model Configuration

● Network unit

Model	Network type
TNU	CC
(1)	(2)
TNU	CC: CC-Link

● Branch unit

Model
TJU
(1)
TJU

● TACnet cable (between TJU and driver controller)

Model	Type	Cable length
CBL	NW	01
(1)	(2)	(3)
CBL	NW	01: 1m
		03: 3m

Use an industrial Ethernet cable between TNU and TJU, and between TJUs.

Specifications

Type		TNU-CC
Fieldbus	Communication standard	CC-Link Ver1.1
	Communication speed [bps]	10M/5M/2.5M/625k/156k
	Number of occupied stations	Four remote device stations
Applicable controller		TLC, THC
THK network	Transmission channel type	RS-485
	Communication speed [bps]	38.4k/57.6k/115.2k
	Communication method	Half duplex
	Maximum trunk length [m]	20
	Maximum number of connectable axes	16
Input power supply		24V DC \pm 10%, up to 0.3A
Operating/storage temperature [°C]		0 to 40°C (No freezing)/-20 to 85°C (No freezing)
Operating/storage humidity [RH %]		90 or below (No condensation)
Ambient condition		An indoor place (not exposed to direct sunlight) free from corrosive gas, flammable gas, oil mist, and dust
Protective function		Higher-level network communication error, communication error, system error
Weight [g]		240 (TJU: 220)

Dimensions

● TNU

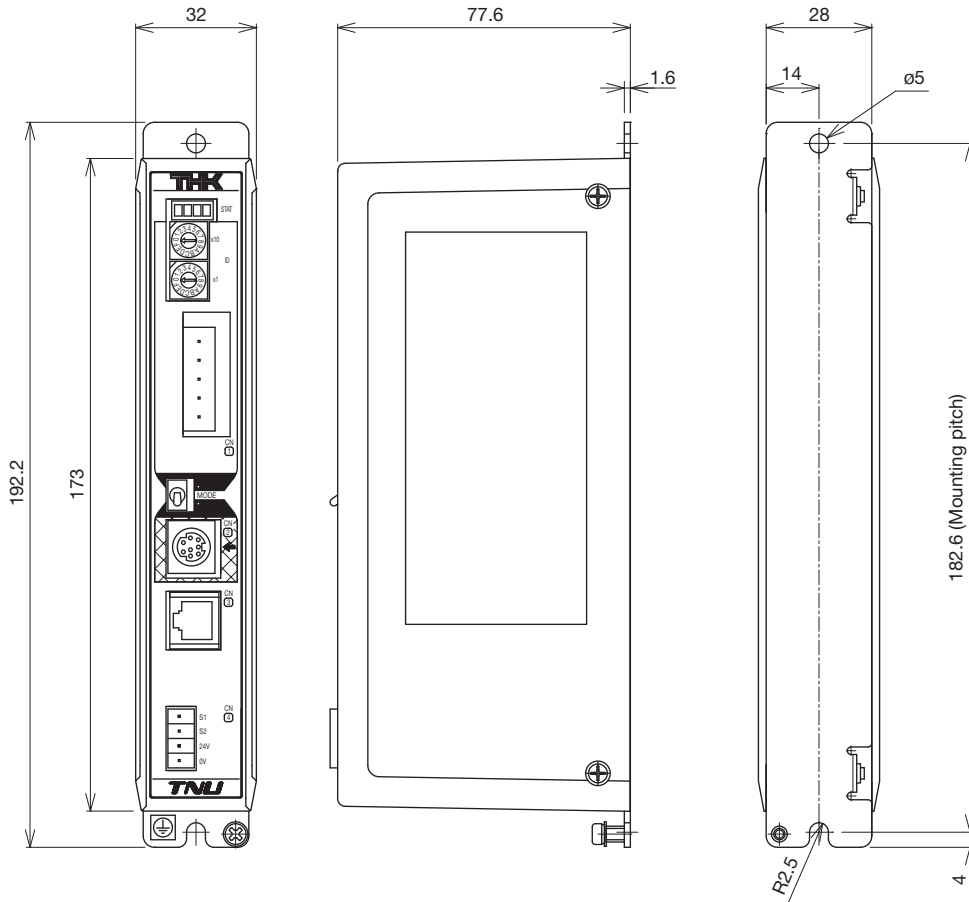

● TJU

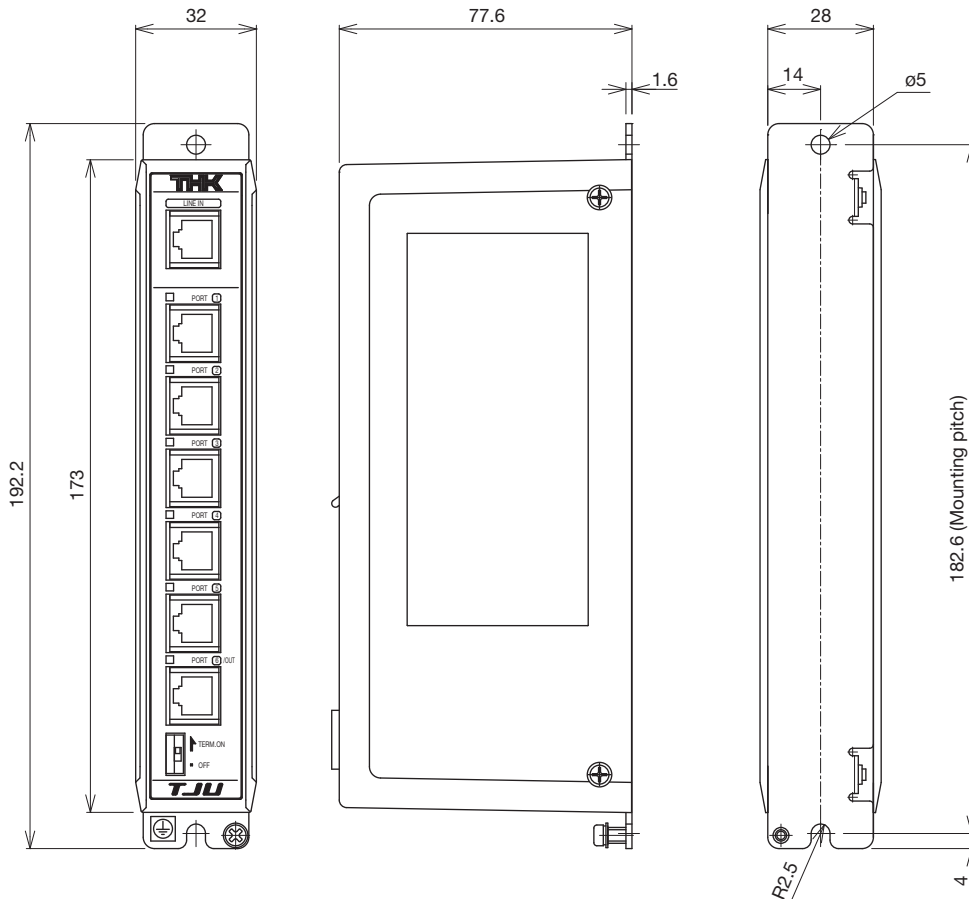

The external dimensions and mounting dimensions of TNU and TJU are the same.

ES/EC

KRF

US/USW

PCT/PC

Controller

Components

● TNU

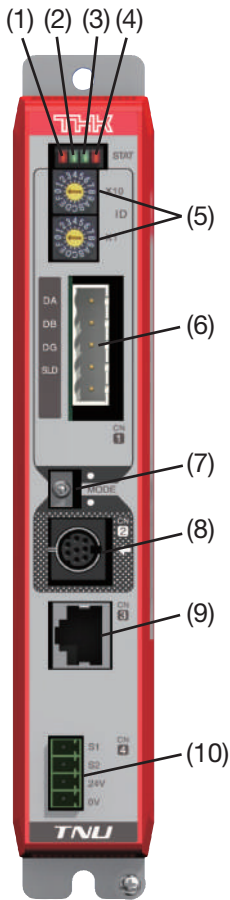

- (1) Power-on display (red)
- (2) CC-Link communication status display (green)
- (3) TACnet status display (green)
- (4) Error display (red)
- (5) CC-Link ID setting switch
- (6) CC-Link communication connector CN1
- (7) Higher-level device selection switch
- (8) Communication connector CN2
- (9) Communication connector CN3
- (10) Power supply connector CN4

● TJU



- (1) Input port (higher-level connection)
- (2) Output port (lower-level connection)
- (3) Terminating resistance selection switch

External Device Connection (TNU)

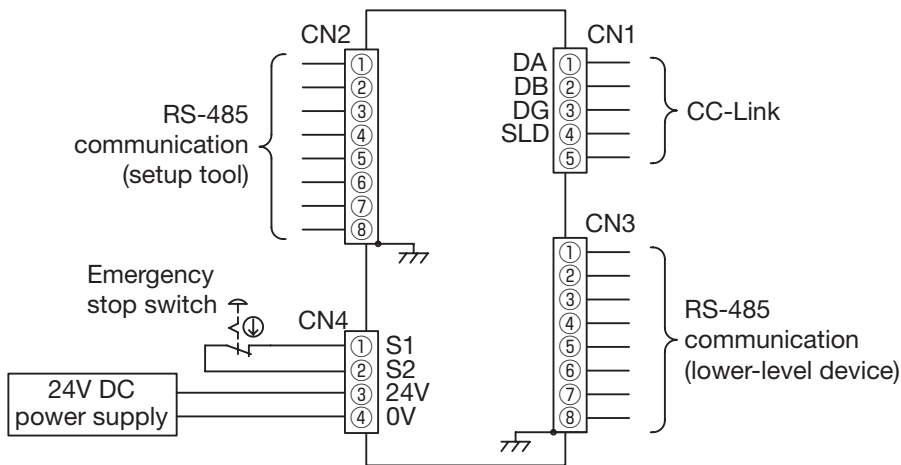

Note: The emergency stop terminals (CN4-S1 and S2) are not used for power shutdown of TNU, but used for an emergency stop of the lower-level device (THK driver controller).

TDO Digital operator (separate order required)



Features

Simple, quick operations and settings of TLC and THC are possible without using a PC.

Simple Operation

Key sheet with a straightforward design,
LC with backlight (20 digits × 4 lines).

Functions

- Checking and editing step data and parameters
 - Operation of actuator
(Return to home position, Jog operation, Inching operation, Program execution, Servo ON/OFF, Electromagnetic brake ON/OFF)
 - Monitor (I/O, Current position, Position command, Current command, Version display)
 - Alarm (History display, Clear history, Interrupt display on occurrence, Alarm reset)
 - Settings (Backlight luminance, LCD contrast, Beep tone, Automatic turn off of backlight)
 - Enable switch (3 positions) - Protection structure IP54 (excluding cable connectors) - Display language (Japanese/English)
- External dimensions: 110mm (W) × 218.3mm (H) × 66.6mm (D) (excluding crests)
Main unit weight: 400g (excluding cables) Cable length: 5m
TLC/THC is supported with Version 1.03 or later.
TNU is supported with Version 1.10 or later.

Model Configuration

Model	Type
TDO	N
(1)	(2)
TDO	N: Category 2* compliant type
	* ISO 13849-1

D-STEP PC setup tool

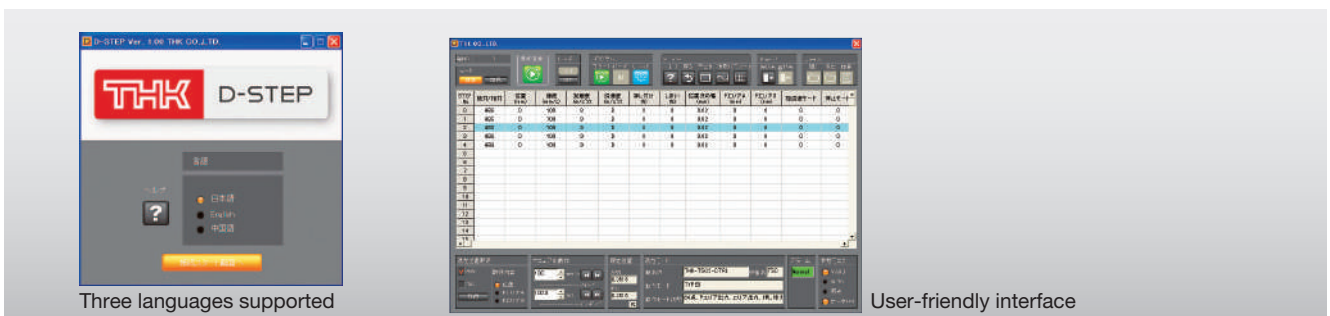

Features

Supports multifunctional TLC/THC with user-friendly interface.

Simple Operation

Operations and settings of TLC and THC are possible using a PC.
Equipped with functions useful for maintenance, such as backing up data or logging operating states.

Functions

- Checking, editing, backing up, or offline-editing of step data
 - Checking, editing, backing up, or offline-editing of parameters
 - Operations of actuator (Return to home position, Jog operation, Inching operation, Program execution, Servo ON/OFF)
 - Monitor (I/O, Current position, Position command, Current command) - Logging (Speed and current waveform display)
 - Alarm (History display, Clear history, Alarm reset) - Display language (Japanese/English/Simplified Chinese)
- Supported OS: Windows XP/Windows Vista/Windows 7
D-STEP can be freely downloaded from the THK technical support website (<https://tech.thk.com/>).
TLC/THC/TNU is supported with Version 1.10 or later.

Cable

I/O cable: CBL TSC IO ** (optional)

** indicates cable length: 03 (3m), 05 (5m), 07 (7m), or 10 (10m).

Cables are shipped with the discrete wire side terminals unprocessed.
Cables are used for TLC/THC.

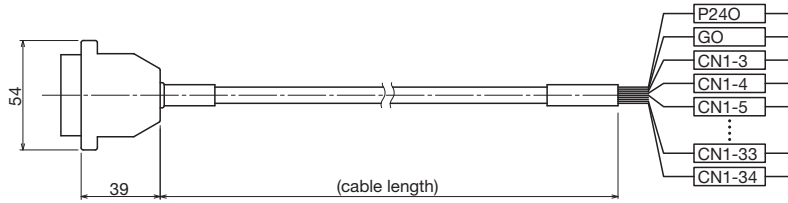

PC communications cable: CBL-COM-03 (optional)

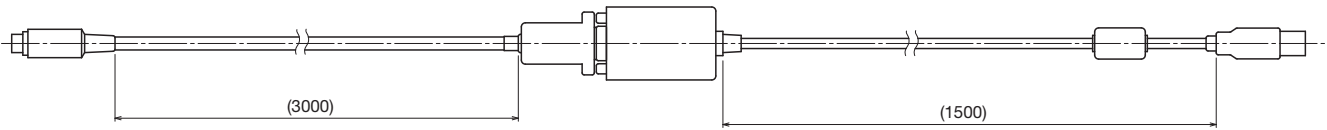

ES/EC

KRF

US/USW

PCT/PC

Controller

ES/EC

KRF

US/USW

PCT/PC

Controller