

Nut Bracket

Model MC

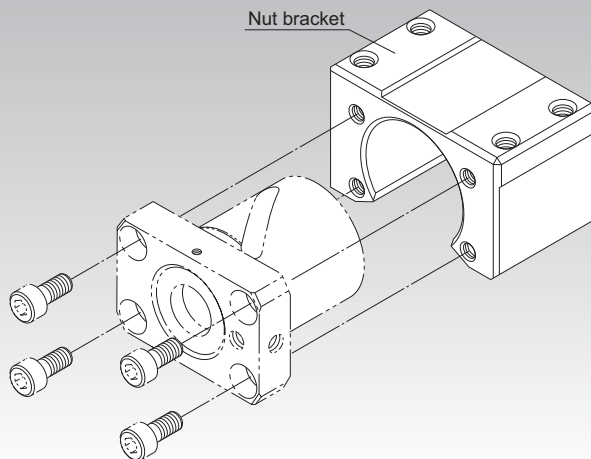

Fig. 1: Structure of the Nut Bracket

Structure and Features

The Model MC nut bracket is designed to be used with nuts for Model BNK precision ball screw with finished shaft ends. Its low height and the fact that it can be assembled using only bolts allows for compact devices and reduces assembly times.

Type

Nut Bracket Model MC

Dimensional Table⇒ [A15-351](#)

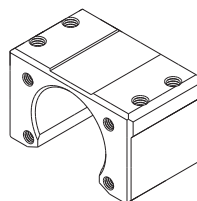

Nut Bracket

Model No.	Supported models of ball screw
MC 1004	BNK1004, BNK1010
MC 1205	BNK1205
MC 1408	BNK1408, BNK1510, BNK1520, BNK1616
MC 2010	BNK2010
MC 2020	BNK2020

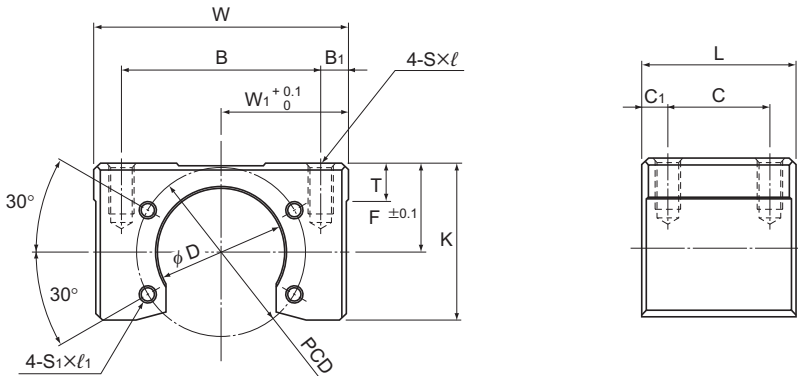

Unit: mm

Model No.	Width		B	B ₁	Overall length L	C	C ₁	F	K
	W	W ₁							
MC 1004	48	24	40	4	32	16	10	20	32.5
MC 1205	60	30	47	6.5	36	24	6	21	37
MC 1408	60	30	50	5	36	20	10	21.5	37
MC 2010	86	43	70	8	50	30	10	31	54
MC 2020	86	43	70	8	40	24	8	28	51

Model No.	T	D	PCD	S × ℓ	S ₁ × ℓ ₁	Mass kg
MC 1004	9	26.4	36	M5 × 10	M4 × 7	0.24
MC 1205	9	30.4	40	M6 × 12	M4 × 7	0.38
MC 1408	9	34.4	45	M6 × 12	M5 × 7	0.34
MC 2010	16	46.4	59	M10 × 20	M6 × 10	1.04
MC 2020	16	39.4	59	M10 × 20	M6 × 10	0.83