

Model HBN

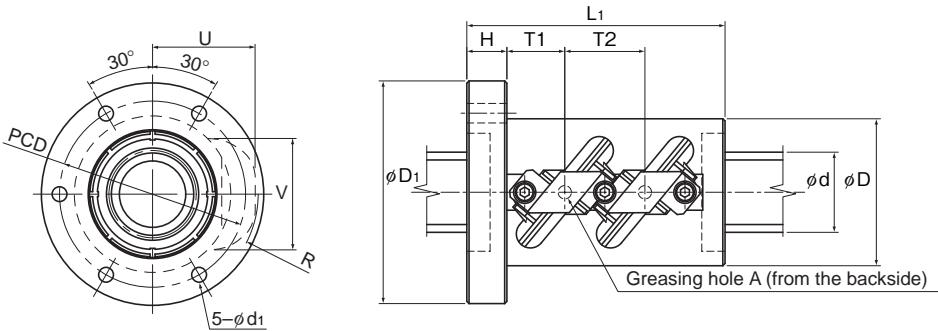

Models HBN3210 to 3612

Model No.	Screw shaft outer diameter d	Lead Ph	Ball center-to-center diameter dp	Thread minor diameter dc	No. of loaded circuits Rows x turns	Basic load rating		Permissible load* F _P kN	Rigidity K N/μm
						Ca kN	C _{0a} kN		
HBN 3210-5	32	10	34	26	2×2.5	102.9	191.3	31.9	1077
HBN 3610-5	36	10	38	30	2×2.5	108.2	220.4	33.5	1176
HBN 3612-5	36	12	38.4	29	2×2.5	141.1	267.7	43.7	1207
HBN 4010-7.5	40	10	42	34	3×2.5	162.6	336	50.4	1910
HBN 4012-7.5	40	12	42.4	33	3×2.5	212.4	441.6	65.8	1922
HBN 5010-7.5	50	10	52	44	3×2.5	179.1	462.7	55.5	2279
HBN 5012-7.5	50	12	52.4	43	3×2.5	235.7	572.2	73.1	2345
HBN 5016-7.5	50	16	53	39.6	3×2.5	379.6	820.9	117.7	2392
HBN 6316-7.5	63	16	66	52.6	3×2.5	427.1	1043.8	132.4	2898
HBN 6316-10.5	63	16	66	52.6	3×3.5	577.1	1461.3	178.9	4029
HBN 6320-7.5	63	20	66.5	49.6	3×2.5	578.8	1283.1	179.4	3030

Note) The permissible load F_P* indicates the maxim axial load that the Ball Screw can receive.

This model is capable of achieving a longer service life than the conventional Ball Screw under a high load.

For the axial clearance, this model has clearance G2 as the standard. Other clearance is also available at your request.
Contact THK for details.

Model number coding

HBN3210-5 RR G2 +1200L C7

Model number Seal symbol (*1)

Accuracy symbol (*3)

Overall screw shaft length (in mm)

Symbol for clearance in the axial direction (*2)

(*1) See A15-162. (*2) See A15-25. (*3) See A15-18.

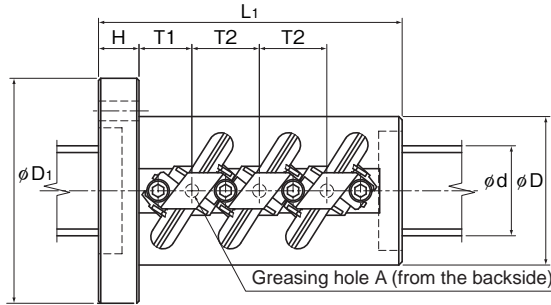

Models HBN4010 to 6320

Unit: mm

Nut dimensions													Screw shaft inertial moment/mm	Nut mass	Shaft mass
Outer diameter	Flange diameter	Overall length	H	PCD	d _i	T1	T2	U _{MAX}	V _{MAX}	R _{MAX}	Greasing hole				
D	D ₁	L ₁	H	PCD	d _i	T1	T2	U _{MAX}	V _{MAX}	R _{MAX}	A	kg·cm ² /mm	kg	kg/m	
58	85	98	15	71	6.6	22	30	43	46	43.5	M6	8.08 × 10 ⁻³	1.8	5.26	
62	89	98	15	75	6.6	22	30	45	50	46	M6	1.29 × 10 ⁻²	1.9	6.79	
66	100	116	18	82	9	26	36	49	52.5	50	M6	1.29 × 10 ⁻²	2.8	6.55	
66	100	135	18	82	9	23.5	30	46.5	54	48	M6	1.97 × 10 ⁻²	2.9	8.52	
70	104	152	18	86	9	26	36	51	56	52	M6	1.97 × 10 ⁻²	3.7	5.24	
78	112	135	18	94	9	23.5	30	52	63.5	54.5	M6	4.82 × 10 ⁻²	3.7	13.7	
80	114	152	18	96	9	26	36	56	66	58.5	M6	4.82 × 10 ⁻²	4.4	13.34	
95	135	211	28	113	9	37.5	48	64.5	69.6	65.2	PT 1/8	4.82 × 10 ⁻²	10.0	12.1	
105	139	211	28	122	9	37.5	48	70.5	82	72.5	PT 1/8	1.21 × 10 ⁻¹	10.6	20.2	
105	139	259	28	122	9	53.5	64	70.5	82	73	PT 1/8	1.21 × 10 ⁻¹	17.4	20.2	
117	157	252	32	137	11	44	60	79	86.5	80	PT 1/8	1.21 × 10 ⁻¹	17.2	19.13	

Note) The rigidity values in the table represent the spring constants obtained from the load and the elastic deformation when providing an axial load, 30% of the basic dynamic load rating (Ca).

These values do not include the rigidity of the components related to mounting the ball screw nut. Therefore, it is normally appropriate to regard roughly 80% of the value in the table as the actual value.

If the axial load (Fa) is not 0.3 Ca, the rigidity value (K_N) is obtained from the following equation.

$$K_N = K \left(\frac{F_a}{0.3Ca} \right)^{\frac{1}{3}}$$

K: Rigidity value in the dimensional table.