

SANUPS E23A

Online UPS

Ver. 2.1
English



SANUPS E23A

Highly reliable and efficient parallel processing UPS



Parallel processing topology

While the most common UPS topology is double conversion online, this UPS has the parallel processing topology. At normal times, this UPS not only powers the load using the grid power, but also corrects the voltage and absorbs noise with its bi-directional inverter connected in parallel. It provides high-quality power to ICT devices. This topology achieves both high efficiency and high-quality power.

Lineup

[No. of phases/wires] Input/Output voltage	Output capacity		Battery backup time*		Model
	[kVA]	[kW]	Standard	Available options	
[3-phase 3-wire] 200 V model 200/205/210 V	20	16	8 min	30/60/120/180 min	E23A203
	50	40	10 min		E23A503
	100	80			E23A104
	200	160			E23A204

* At a 25°C ambient temperature and load power factor of 0.8, using new, fully charged batteries.

High Efficiency

- Achieves a conversion efficiency of 97%.
- Contributes to environmental preservation.

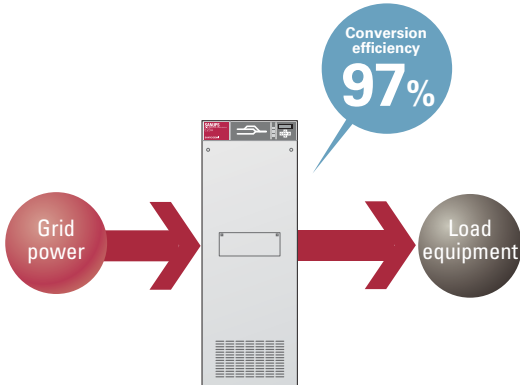

Comparison of annual power consumption (For 200 kVA model)

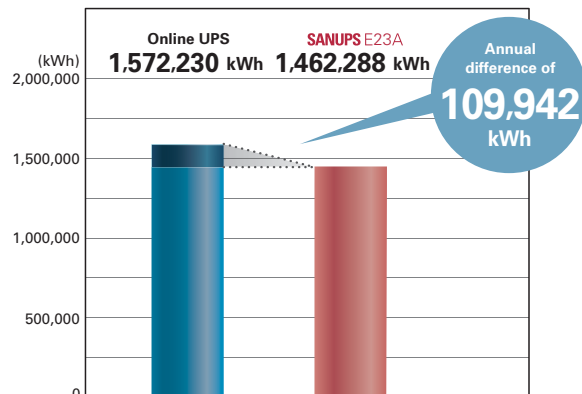

Note: Including the power consumption of the powered load equipment and UPS cooling devices.

Circuit Block Diagram

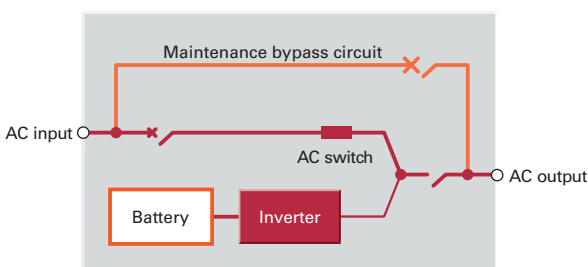

Note: For 20 kVA, 8-minute backup model (built-in battery).

High Quality

Zero interruption

Many computers and communications equipment installed in production facilities are designed assuming a power supply without interruptions.

- In the event of an outage or voltage dip, this UPS provides uninterrupted sine wave power, eliminating the risk of equipment malfunction.
- Even if the grid power contains a surge or noise, the UPS will output a clean sinusoidal wave, allowing the load devices to be used with confidence.*

*In the event of a voltage dip or momentary outage, power will be supplied from capacitors, preventing unnecessary battery discharge.

Active filter

- The active filter includes a bi-directional inverter that cancels the harmonics generated by equipment, making the source current of the UPS sinusoidal.
- The corrected current waveform is harmless to the power grid and other equipment. Furthermore, the power factor can be corrected to nearly 1.0.

Waveforms during outage

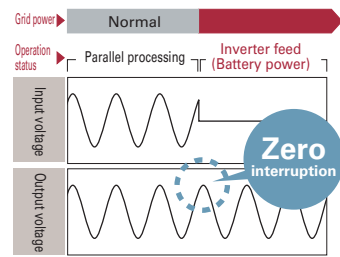

Waveforms with surge

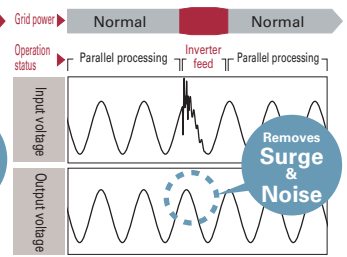

Potential consequences of grid failure:

- Reset or stop of computers
- Communication failure of network equipment
- Stop or failure of production line equipment
- Defect quality in semiconductor manufacturing equipment

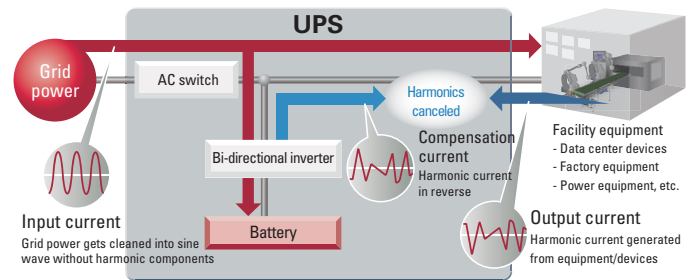

High Reliability

Automatic battery self-test

- Battery self-tests can be performed automatically at regular intervals, ensuring reliable operation in the event of a power failure.

- These battery self-tests are done while power is supplied from the grid, so there is no effect on the UPS even if the battery has degraded.

Note: Battery test interval can be set by the user.

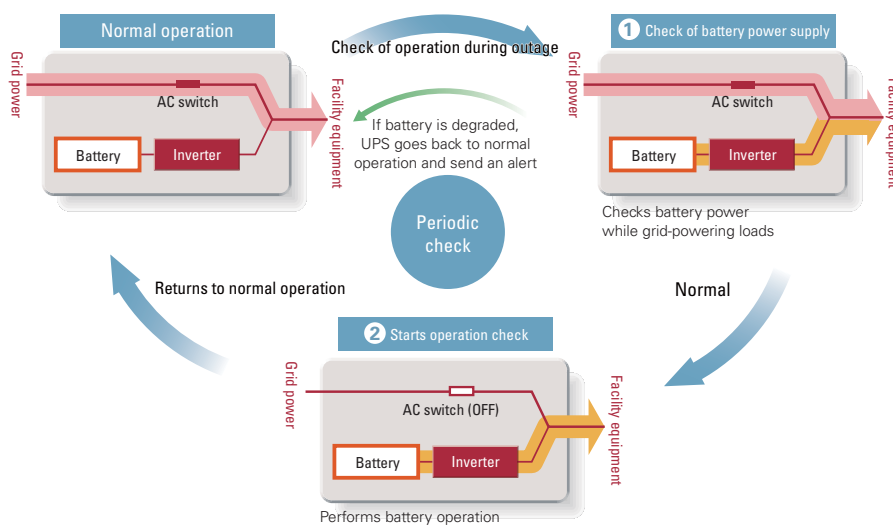

Specifications

Model	E23A203	E23A503	E23A104	E23A204	Remarks		
Rated output capacity (apparent power / active power)	20 kVA / 16 kW	50 kVA / 40 kW	100 kVA / 80 kW	200 kVA / 160 kW			
Technology	Parallel processing						
	Forced air cooling						
AC input	No. of phases/wires				3-phase 3-wire		
	Rated voltage				200/205/210 V	Same as output voltage	
	Rated frequency				50/60 Hz	To be selected at the time of order	
	Required capacity		20 kVA or less	50 kVA or less	100 kVA or less	200 kVA or less	Excluding 180-min backup models
	Input power factor				0.98 or more	At rated output	
	Current harmonic distortion compensation	Compensation capacity				Within rated capacity	
		Compensation order				2nd to 20th harmonics	
Compensation rate				85% or greater	At 100% rectifier load		
AC output	No. of phases/wires				3-phase 3-wire		
	Rated voltage				200/205/210 V	To be selected at the time of order	
	Voltage regulation	In parallel processing mode			Within -8% to +10% of rated voltage (Factory setting)	User-settable ⁽¹⁾	
		In battery operation			Within ±2% of rated voltage		
	Rated frequency				50/60 Hz	Same as input frequency	
	Frequency regulation	In parallel processing mode			Within ±4% of rated frequency (Factory setting)	User-settable ⁽¹⁾	
		In battery operation			Within ±0.1% of rated frequency		
	Load power factor	Rated				0.8 (lagging)	
		Variation range				0.7 to 1.0 (lagging)	
	Voltage harmonic distortion	At linear load				2% or less	In battery operation
		At rectifier load				5% or less	
	Voltage unbalance	In battery operation				Within 2%	With a load of 1/3 the total capacity on one line
		Transient voltage fluctuation				For abrupt load change	Within ±5% of rated voltage (For 0⇔100% load step changes at rated input)
	Overload capability	Settling time				50 s or less	
In parallel processing mode			200% (for 30 s), 800% (for 0.5 s)				
In battery operation			125% (for 10 min), 150% (for 1 min)				
Transfer time to battery operation				No interruption			
Battery	Type			Small-sized valve-regulated lead-acid (VRLA) battery	Stationary valve-regulated lead-acid (VRLA) battery		
	Backup time				8 min (built-in battery) / 10 min (battery panel)	30/60/120/180 min battery panels also available	
Acoustic noise	57 dB or less	65 dB or less	65 dB or less	70 dB or less	At 1 m height, 1 m from the front of the unit		
Heat dissipation	1.0 kW	2.6 kW	5.1 kW	10.2 kW	At rated output, after battery charging completed ⁽²⁾ (rated backup time)		
Cooling airflow	5.3 m³/min	13.4 m³/min	26.3 m³/min	52.6 m³/min	At rated output, after battery charging completed ⁽²⁾ (rated backup time)		
Ventilation airflow	0.85 m³/min	2.7 m³/min	4.1 m³/min	9.3 m³/min	⁽²⁾ (rated backup time)		
Operating environment	Temperature: 0 to 40°C, humidity: 30 to 90% RH (non-condensing), Installation location: Indoors, altitude: 1000 m or lower						
Expected service life (of the UPS unit excluding battery)	15 years (At a 25°C average ambient temperature. For reference purposes only.)						

(1) If you need to change the voltage or frequency regulation, please contact us.

(2) At a load power factor of 0.8, 40°C room temperature, and 30°C outside temperature.

Load Level vs Backup Time

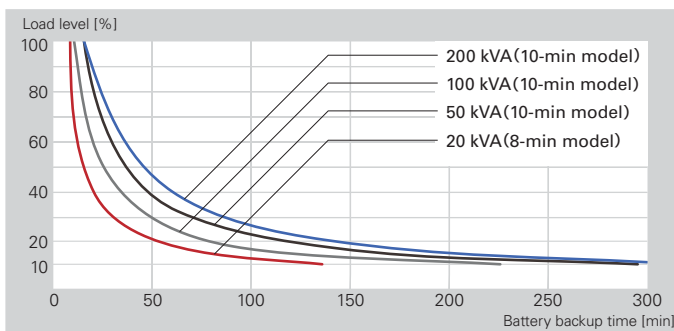

Note: At 25°C ambient temperature and load power factor of 0.8, using new, fully charged batteries.

Dimensions (Unit: mm)

Inverter panel

Model	Capacity	W	D	H1	H2	Mass
E23A203	20 kVA	500	700	1400	125	400 (240) kg*
E23A503	50 kVA			1650		350 kg
E23A104	100 kVA	750	800	1825		600 kg
E23A204	200 kVA	1500				1200 kg

* The values in parentheses are the mass excluding the built-in battery.

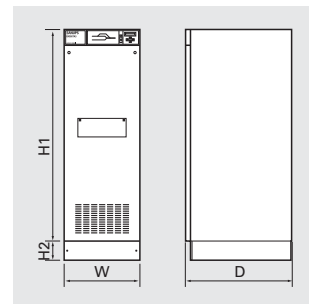

Battery panel

Capacity	Backup time*	Battery			W	D	H1	H2	Mass	Number of faces
		Number of cells	Capacity	Total capacity						
20 kVA	8 min	168	17 Ah	5712 Wh	Battery is built into the inverter panel.					
	30 min	156	44 Ah × 2	27456 Wh	850	700	1650	125	1200 kg	1
	60 min		28 Ah × 4	34944 Wh	1400				1690 kg	2
	120 min		44 Ah × 4	54912 Wh	1700				2350 kg	2
	180 min		300 Ah	93600 Wh	3000	800	1825		4350 kg	3
50 kVA	10 min	156	44 Ah × 2	27456 Wh	850	700	1650	125	1200 kg	1
	30 min		44 Ah × 4	54912 Wh	1700				2400 kg	2
	60 min		300 Ah	93600 Wh	3000	800	1825		4350 kg	3
	120 min		500 Ah	156000 Wh	4000	900			6750 kg	4
	180 min		300 Ah × 2	187200 Wh	6000	800			9000 kg	6
100 kVA	10 min	156	44 Ah × 3	41184 Wh	1350	800	1825	125	1800 kg	2
	30 min		300 Ah	93600 Wh	3000				4500 kg	3
	60 min		500 Ah	156000 Wh	4000	900			6750 kg	4
	120 min		800 Ah	249600 Wh	Contact us for details.					
	180 min		1500 Ah	468000 Wh	Contact us for details.					
200 kVA	10 min	156	200 Ah × 2	124800 Wh	4400	800	1825	125	6000 kg	4
	30 min		300 Ah × 2	187200 Wh	6000				9000 kg	6
	60 min		1000 Ah	312000 Wh	Contact us for details.					
	120 min		2000 Ah	624000 Wh	Contact us for details.					
	180 min		2500 Ah	960000 Wh	Contact us for details.					

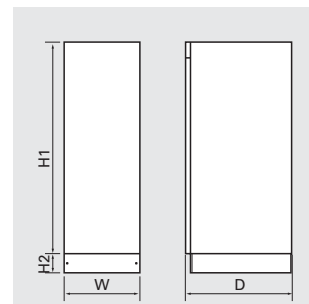

Paint color: Ivory (Munsell 6.6Y 8.3/0.8)

* At a 25°C ambient temperature, load power factor of 0.8, using new, fully charged batteries.

Options

Items	Model no.	Remarks
LAN interface card	PRLANIF031	This card enables 24/7 monitoring of UPS operations and status and sends email notifications to system administrators for quick actions via network in the event of a power failure. The LAN interface card will be shipped installed in the UPS. Combined with a temperature and humidity sensor (Model no.: 9CT1-T, extension cable: CARD-CBL007), this card can also monitor the ambient temperature and humidity. Multiple servers (up to 50) can be shut down through communication protocols such as SSH, Telnet, and REST API.

I/O Panel

An I/O panel is used to obtain single-phase output power or to make a UPS completely de-energized while maintaining power supply to load equipment.

How to read model numbers

TRE23A 203 B 3 2 □⁽¹⁾

Device type

Device	Code
E23A I/O panel	TRE23A

Device capacity

Capacity	Code
20 kVA	203
50 kVA	503
100 kVA	104

Cable entry

Cable entry	Code
Bottom	B
Top ⁽²⁾	T

(1) The □'s denote revision characters.

Single-phase output⁽³⁾

(3) Specify this number if using I/O panel with Scott-T transformer circuit.

Single-phase output	Code
Single-phase 3-wire 200/100 V	3
Single-phase 2-wire 100 V	2

Number of branches for single-phase output⁽³⁾

(3) Specify this number if using I/O panel with Scott-T transformer circuit.

Number of branches	Code
2-branch	2
4-branch	4
6-branch	6
8-branch	8

(2) Top cable entry is for AC input/output wiring, and bottom cable entry is for inter-panel wiring (between I/O panel, inverter panel, and battery panel).

I/O Panel

I/O panel with external maintenance bypass circuit

UPS capacity	Model no.		Dimensions (Unit: mm)				Mass
	Top cable entry	Bottom cable entry	W	D	H1	H2	
20 kVA	TRE23A203T□	TRE23A203B□	400	700	1400	125	170 kg
50 kVA	TRE23A503T□	TRE23A503B□	500		1650		
100 kVA	TRE23A104T□	TRE23A104B□	700	800	1825		220 kg

Top or bottom cable entry can be chosen. Both types have the same dimensions.
The □'s denote revision characters.

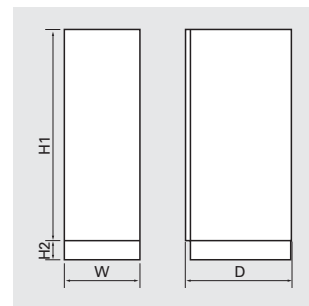

Paint color: Ivory (Munsell 6.6Y 8.3/0.8)

Single-line diagram

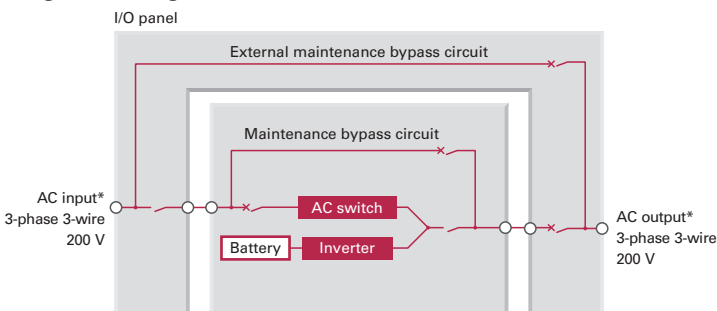

* 3-phase 3-wire 210 VAC input/output is also supported.

I/O panel with Scott-T transformer circuit

UPS capacity	Model no.		Scott-T transformer capacity	Dimensions (Unit: mm)				Mass
	Top cable entry	Bottom cable entry		W	D	H1	H2	
20 kVA	TRE23A203T□□□	TRE23A203B□□□	20 kVA	500	700	1400	125	420 kg
50 kVA	TRE23A503T□□□	TRE23A503B□□□	50 kVA	700		1650		740 kg
100 kVA	TRE23A104T□□□	TRE23A104B□□□	100 kVA	900	800	1825		1000 kg

Model no.		AC output					
Top cable entry	Bottom cable entry	3-phase 3-wire breaker capacity	Single-phase 2-wire or single-phase 3-wire breaker capacity				
			Single-phase	2-branch	4-branch	6-branch	8-branch
TRE23A203T□□□	TRE23A203B□□□	100 AF / 75 AT	2-wire	100 AF / 100 AT	50 AF / 50 AT	50 AF / 40 AT	50 AF / 30 AT
			3-wire	50 AF / 50 AT	50 AF / 30 AT	50 AF / 20 AT	50 AF / 15 AT
TRE23A503T□□□	TRE23A503B□□□	250 AF / 175 AT	2-wire	400 AF / 250 AT	250 AF / 125 AT	100 AF / 100 AT	100 AF / 63 AT
			3-wire	250 AF / 125 AT	100 AF / 63 AT	50 AF / 50 AT	50 AF / 32 AT
TRE23A104T□□□	TRE23A104B□□□	400 AF / 350 AT	2-wire	630 AF / 500 AT	400 AF / 250 AT	250 AF / 175 AT	250 AF / 125 AT
			3-wire	400 AF / 250 AT	250 AF / 125 AT	100 AF / 100 AT	100 AF / 63 AT

Top or bottom cable entry can be chosen. Both types have the same dimensions.

The mass values above are for when the single-phase 2-wire or single-phase 3-wire AC output has 8 branches.

Scott-T transformer output can be selected from single-phase 2-wire or single-phase 3-wire. Make sure that the secondary winding's loads are balanced. Note that the excitation inrush current can be as high as 8 times the rated current.

If you require a breaker capacity other than those listed above, customization will be required. Contact us for details.

The □'s denote single-phase output, the number of branches, and revision characters. Specify model numbers referencing the "How to read model numbers" section for the I/O panel.

Single-line diagram

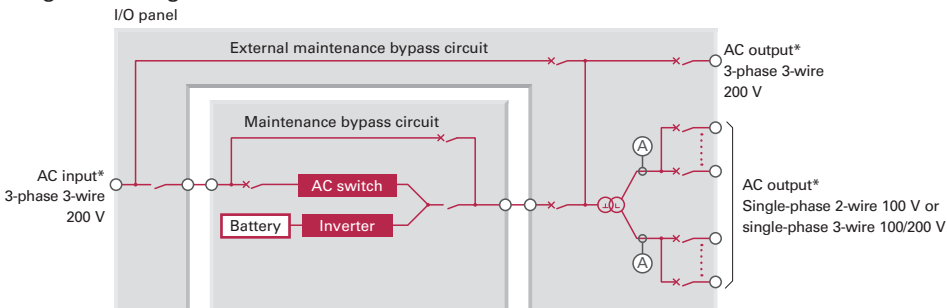

* 3-phase 3-wire 210 VAC input/output is also supported.

Specify the number of branches (2, 4, 6, or 8) for single-phase AC output. Single-phase 2-wire 105 V and single-phase 3-wire 105/210 V outputs are also supported.



■ Eco Products

Eco Products are eco-friendly products designed to reduce the environmental impact of the product and its packaging materials compared to conventional products on the market.

Our products are assessed over the product's life cycle against our own eco-design requirements including product size, weight, power consumption, and CO₂ emissions, and those meeting our standards and higher standards qualify as Eco Products and Eco Products Plus, respectively.

● Fire Service Law and Fire Prevention Ordinance in Japan

The Fire Prevention Ordinance regulates the total battery capacity of storage batteries, including lithium-ion batteries, that can be installed indoors. When installing UPSs indoors, check that the total battery capacity of a given location does not exceed 20 kWh. If exceeded, consult with your local fire department. Note that the UPSs cannot be used as an emergency power supply for firefighting equipment.

● Building Standard Law in Japan

The UPSs cannot be used as backup power for building facilities conforming to the disaster management requirements defined in the Building Standard Law.

Notes before Purchase

- Before installing, assembling, and using the products, please read Instruction Manual carefully and use them properly.
- When using the products in the following applications, consult with us in advance because special considerations are required for operation, maintenance, and management.
 - (a) Medical equipment that may have direct effects on human life or human body.
 - (b) Trains, elevators, and other machinery that can cause injury.
 - (c) Socially and publicly important computer systems.
 - (d) Other equipment that is related to safety of human life and that can have major impact on maintenance of public functions.
- For use in an environment where vibration is present, such as in a car or a ship, please consult with us in advance.
- Never attempt to disassemble or alter the products in any way.
- For installation and maintenance work of the products, please consult with us or properly licensed personnel.
- Please contact us concerning the disposal of used storage batteries supplied by SANYO DENKI.
- The products listed in this catalog fall into the category 16 of Appended Table 1 of the Export Trade Control Order. To export the products as an individual part or to export a device into which the products are assembled, the "Inform Requirements" and "Objective Requirements" that the Ministry of Economy, Trade and Industry of Japan established based on the "Catch-all Controls" must be studied for applicability. Accordingly, appropriate export formalities must be performed.
- SANYO DENKI will not be liable for any direct or indirect damages or loss, including but not limited to equipment downtime, missed power sales revenue, business interruptions, increased power purchases, resulting from the use of or inability to use our products or services.
- The products listed in this catalog are equipped with lithium-ion batteries. When transporting the products, do not transport by air. When transporting by sea, transport must be carried out according to the International Maritime Dangerous Goods (IMDG) Code. Also, depending on the country and region, there are cases where regulations are established independently, so please consult with the shipping company in advance.

For any inquiry or consultation, please contact a SANYO DENKI sales representative.

SANYO DENKI CO., LTD. 3-33-1 Minami-Otsuka, Toshima-ku, Tokyo 170-8451, Japan TEL: +81 3 5927 1020

<https://www.sanyodenki.com/>

The names of companies and/or their products specified in this document are the trade names, and/or trademarks and/or registered trademarks of such respective companies.

San Ace, SANUPS, and SANMOTION are registered trademarks of SANYO DENKI CO., LTD.

Specifications are subject to change without notice.

CATALOG No.P0763B018 '25.3