

# Overload Protection Equipment TORQUE LIMITERS

**Application** Semiconductor manufacturing equipment, textile machinery, printing machinery

## Detecting an Overload Reliably and Taking Appropriate Action to Protect the Machine against Overload

This torque limiter detects an overload and disconnects the input side and the output side immediately to protect the machine. Because it is the one-position engagement type, when the overload is removed, the input and output are automatically connected with the same torque in the same indexing position. In contrast to the friction type, this type can be used even in adverse environments.

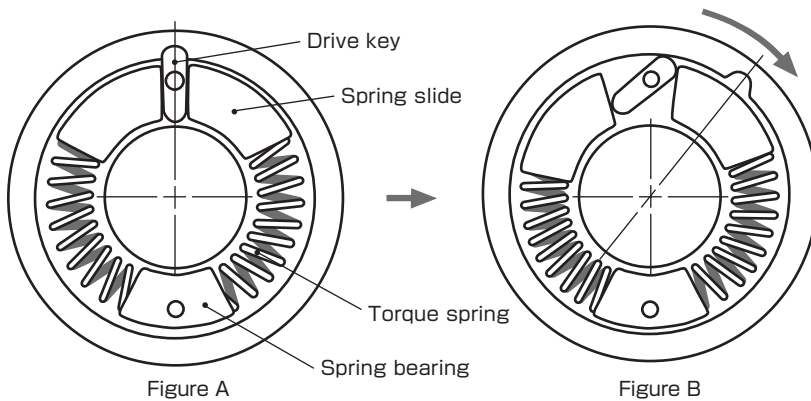

1. Normally the drive key is engaged with the groove of the housing to transmit torque. (Figure A)
2. If an overload is applied, the drive key is tilted against the force of the torque spring and disconnected from the groove of the housing to disconnect the input side and the output side. (Figure B)
3. When the input side and the output side are returned to the original indexing position after removing the overload, the operation can be restarted with the torque that was set originally.
4. The normal and reverse rotation torque can be changed by independently connecting normal and reverse rotation torque springs. (Please contact Miki Pulley for details.)

Available Models

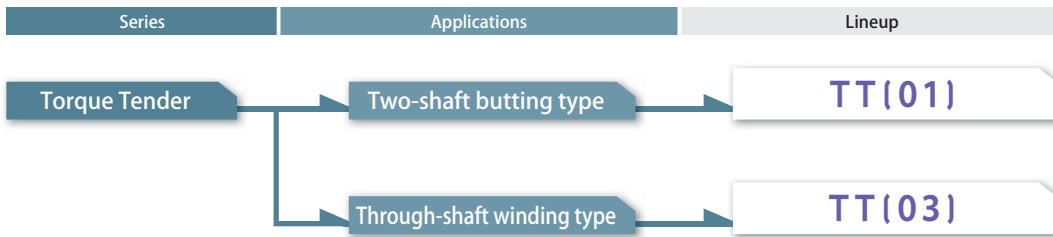

\* Torque tender is the name of Miki Pulley's overload protection equipment

TT(01) Types (Two-shaft Butting Type)

The two-shaft butting type is made by inserting two shafts from both ends (housing and hub) of the torque tender and securing them with set screws to transmit power and protect the machine against overload.

The two-shaft butting type can also be used as a flexible coupling.

- Set torque: 0.2 to 200 N · m
- Applied shaft diameter: 8 to 50 mm

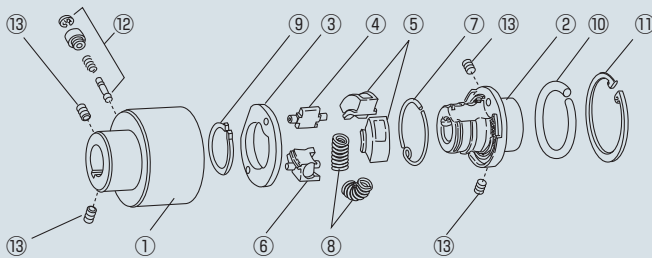
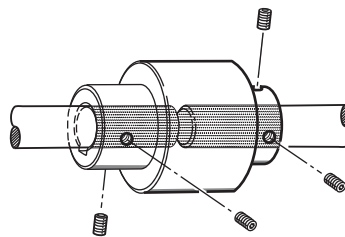

- ① Housing ② Hub ③ Hub ring ④ Drive key ⑤ Spring slide ⑥ Spring bearing
- ⑦ Reset spring ⑧ Torque spring
- ⑨ Stop ring ⑩ Stop ring washer
- ⑪ Stop ring ⑫ Signal pin (option)
- ⑬ Set screws (included)

TT(03) Types (Winding Type)

The winding type is made by inserting the shaft into the inside (hub) of the torque tender and attaching a pulley, sprocket, or gear to the outside of the housing to transmit power and protect the machine against overload.

The shaft is designed to be secured at the center of the main unit so it can be attached even if its end is structured as a through-shaft.

- Set torque: 0.2 to 200 N · m
- Applied shaft diameter: 8 to 45 mm

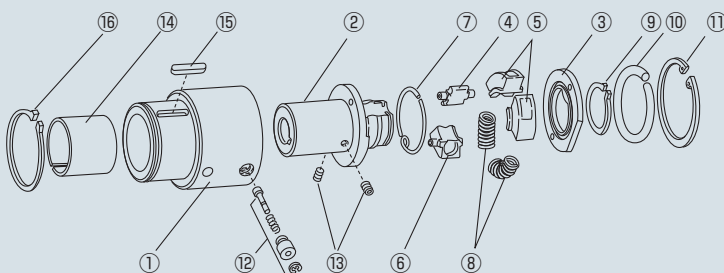
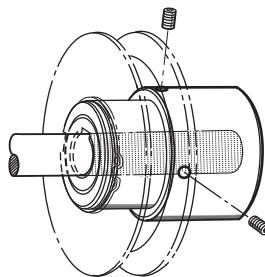

- ① Housing ② Hub ③ Hub ring ④ Drive key ⑤ Spring slide ⑥ Spring bearing
- ⑦ Reset spring ⑧ Torque spring
- ⑨ Stop ring ⑩ Stop ring washer
- ⑪ Stop ring ⑫ Signal pin (option)
- ⑬ Set screws (included) ⑭ Oilless metal
- ⑮ Outer diameter key (included)
- ⑯ Stop ring (included)

# TT(01)Types

## Specifications

Model	Size	Set torque value [N·m] (1500min <sup>-1</sup> )										Misalignment		Max. rotation speed [min <sup>-1</sup> ]	Moment of inertia [kg·m <sup>2</sup> ]	Mass [kg]
		0.2	0.5	1.0	1.5	2.0	2.5	3.0	3.5	4.0	Parallel [mm]	Angular [°]				
TT-1X-01	1X	0.2	0.5	1.0	1.5	2.0	2.5	3.0	3.5	4.0	0.2	0.5	1800	$0.06 \times 10^{-3}$	0.3	
TT-2-01	2	1	2	3	4	5	6	7	8	10	0.2	0.5	1800	$0.26 \times 10^{-3}$	0.7	
TT-2X-01	2X	2	3	5	8	10	12	15	18	20	0.2	0.5	1800	$0.52 \times 10^{-3}$	1.0	
TT-3-01	3	5	8	10	15	20	25	30	35	40	0.2	0.5	1800	$1.23 \times 10^{-3}$	1.5	
TT-3X-01	3X	10	16	20	30	40	50	60	70	80	0.2	0.5	1800	$1.94 \times 10^{-3}$	2.7	
TT-4X-01	4X	20	30	50	80	100	120	150	180	200	0.2	0.5	500	$14.8 \times 10^{-3}$	6.3	

\* The set torque values in the table above are those when the rotation speed is 1500 min<sup>-1</sup>. The operation torque varies depending on the operating rotation speed. Please check P557.

\* Set torque values vary by ± 20%.

\* If you need durability for the torque values in the shaded area, select a larger size.

## Dimensions

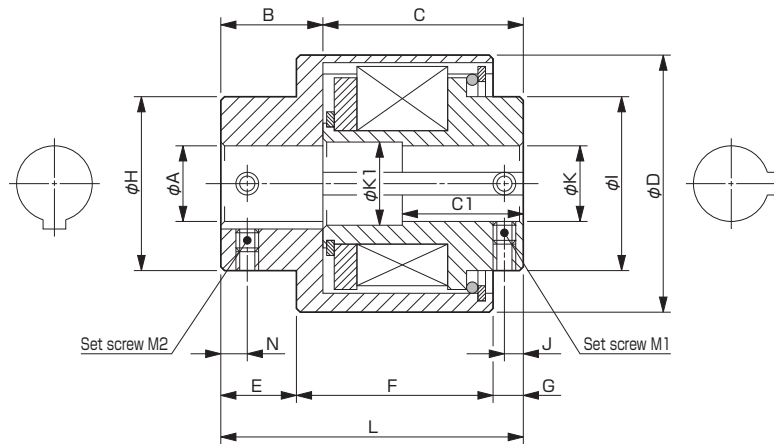

Size	K1	B	C	C1	D	E	F	G	H	I	J	L	N	M1	M2
1X	12.5	20	30	23	42	15	30	5	25	22	3	50	6	2-M4	2-M4
2	16.5	24.5	41.5	32.5	55	20	35	11	35	32	5	66	7	2-M5	2-M5
2X	20.5	31	45	34	65	25	40	11	40	38	5	76	8	2-M5	2-M5
3	25.5	37.5	53.5	40	75	30	50	11	45	45	5	91	10	2-M6	2-M6
3X	25.5	36	85	41	75	30	80	11	45	45	6	121	10	2-M6	2-M6
4X	28.5	46	95	60	120	35	90	16	80	80	8	141	12	2-M10	2-M10

Unit [mm]

\* For size 4X with φ K at 30 mm or more, shape is straight and there are no K1/C1 dimensions.

## Torque coefficient

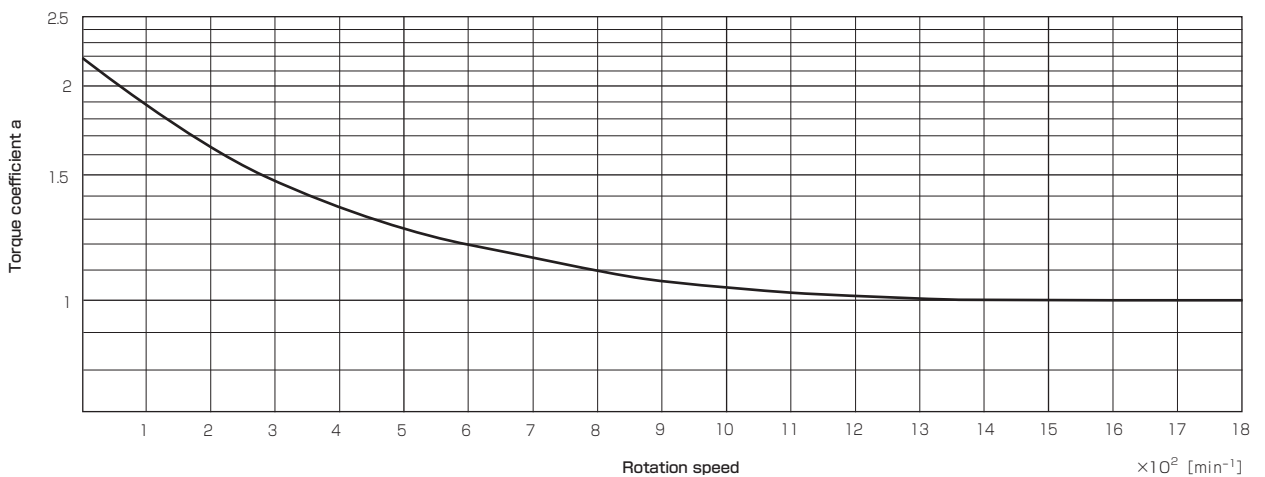

\* Use size 4X at a rotation speed equal to or less than 500 min<sup>-1</sup>.

## Standard Bore Diameter $\phi$ A

Model	Bore Drilling Standards	Nominal bore diameter	Standard bore diameter A [mm]																							
			8	10	11	12	14	15	16	18	19	20	22	24	25	28	30	32	35	38	40	42	45	48	50	
TT-1X-01	Old JIS standards (E9)	Blank	●	●	●	●	●																			
	JIS standards (H9)	H		●	●	●	●																			
	Motor standards	N					●																			
TT-2-01	Old JIS standards (E9)	Blank			●	●	●	●	●	●	●	●														
	JIS standards (H9)	H			●	●	●	●	●	●	●	●														
	Motor standards	N					●				●															
TT-2X-01	Old JIS standards (E9)	Blank					●	●	●	●	●	●	●	●												
	JIS standards (H9)	H					●	●	●	●	●	●	●	●												
	Motor standards	N					●				●			●												
TT-3-01	Old JIS standards (E9)	Blank								●	●	●	●	●	●	●	●	●								
	JIS standards (H9)	H								●	●	●	●	●	●	●	●	●								
	Motor standards	N								●			●			●										
TT-3X-01	Old JIS standards (E9)	Blank								●	●	●	●	●	●	●	●	●								
	JIS standards (H9)	H								●	●	●	●	●	●	●	●	●								
	Motor standards	N								●			●			●										
TT-4X-01	Old JIS standards (E9)	Blank								●	●	●	●	●	●	●	●	●	●	●	●	●	●	●	●	●
	JIS standards (H9)	H								●	●	●	●	●	●	●	●	●	●	●	●	●	●	●	●	●
	Motor standards	N								●			●			●			●			●		●		●

\* There is no keyway for bore diameter  $\phi$  8 mm. \* For the bore drilling standards, see P555.

## Standard Bore Diameter $\phi$ K

Model	Bore Drilling Standards	Nominal bore diameter	Standard bore diameter K [mm]																						
			8	10	11	12	14	15	16	18	19	20	22	24	25	28	30	32	35	38	40	42	45	48	50
TT-1X-01	Old JIS standards (E9)	Blank	●	●	●	●																			
	JIS standards (H9)	H		●	●	●																			
	Motor standards	N																							
TT-2-01	Old JIS standards (E9)	Blank			●	●	●	●	●																
	JIS standards (H9)	H			●	●	●	●	●																
	Motor standards	N					●																		
TT-2X-01	Old JIS standards (E9)	Blank					●	●	●	●	●	●													
	JIS standards (H9)	H					●	●	●	●	●	●													
	Motor standards	N					●				●														
TT-3-01	Old JIS standards (E9)	Blank								●	●	●	●	●	●										
	JIS standards (H9)	H								●	●	●	●	●	●										
	Motor standards	N								●			●												
TT-3X-01	Old JIS standards (E9)	Blank								●	●	●	●	●	●										
	JIS standards (H9)	H								●	●	●	●	●	●										
	Motor standards	N								●			●			●									
TT-4X-01	Old JIS standards (E9)	Blank								●	●	●	●	●	●	●	●	●	●	●	●	●	●	●	●
	JIS standards (H9)	H								●	●	●	●	●	●	●	●	●	●	●	●	●	●	●	●
	Motor standards	N								●			●			●			●			●		●	

\* There is no keyway for bore diameter  $\phi$  8 mm. \* For the bore drilling standards, see P555.

### How to Place an Order

TT-2X-01-14N-19H-10NM-P

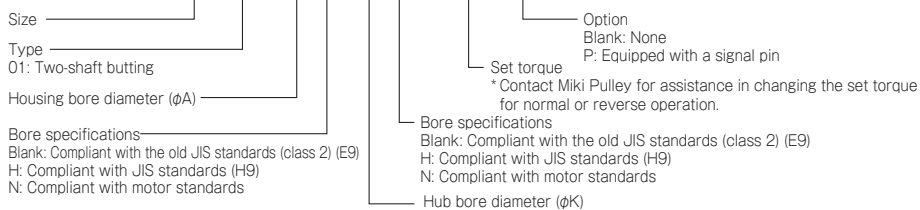

# TT(03)Types

## Specifications

Type	Size	Set torque value [N·m] (1500min <sup>-1</sup> )										Max. rotation speed [min <sup>-1</sup> ]	Moment of inertia [kg·m <sup>2</sup> ]	Mass [kg]		
		0.2	0.5	1.0	1.5	2.0	2.5	3.0	3.5	4.0	8				10	18
TT-1X-03	1X	0.2	0.5	1.0	1.5	2.0	2.5	3.0	3.5	4.0	1800	$0.09 \times 10^{-3}$	0.4			
TT-2-03	2	1	2	3	4	5	6	7	8	10	1800	$0.31 \times 10^{-3}$	0.8			
TT-2X-03	2X	2	3	5	8	10	12	15	18	20	1800	$0.66 \times 10^{-3}$	1.1			
TT-3-03	3	5	8	10	15	20	25	30	35	40	1800	$1.59 \times 10^{-3}$	1.7			
TT-3X-03	3X	10	16	20	30	40	50	60	70	80	1800	$2.43 \times 10^{-3}$	3.0			
TT-4X-03	4X	20	30	50	80	100	120	150	180	200	500	$15.8 \times 10^{-3}$	6.5			

\* The set torque values in the table above are those when the rotation speed is 1500 min<sup>-1</sup>. The operation torque varies depending on the operating rotation speed. Please check P557.  
 \* Set torque values vary by ± 20%.  
 \* If you need durability for the torque values in the  area, select a larger size.

## Dimensions

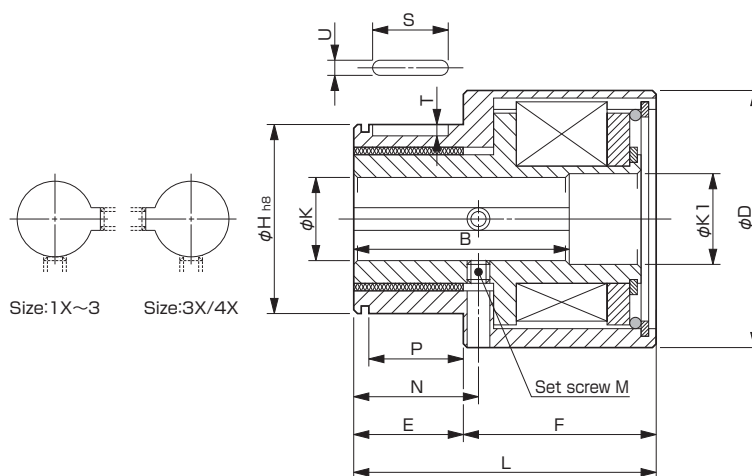

Size	K1	B	D	E	F	H	N	L	P	S	T	U	M	Unit [mm]
1X	12.5	34.5	42	20	35	30	25	55	16	14	2.5	4	2-M4	
2	16.5	38.5	55	25	40	40	30	65	20	18	3	5	2-M5	
2X	20.5	40.5	65	25	45	45	31	70	20	18	3	5	2-M5	
3	25.5	52.5	75	35	55	60	45	90	30	28	4	7	2-M6	
3X	25.5	75	75	35	90	60	45	125	30	28	4	7	2-M6	
4X	46	100	120	50	90	85	57	140	45	40	4.5	12	2-M8	

\* The outer diameter key (old JIS class 2) and stop ring are included accessories.

## Torque coefficient

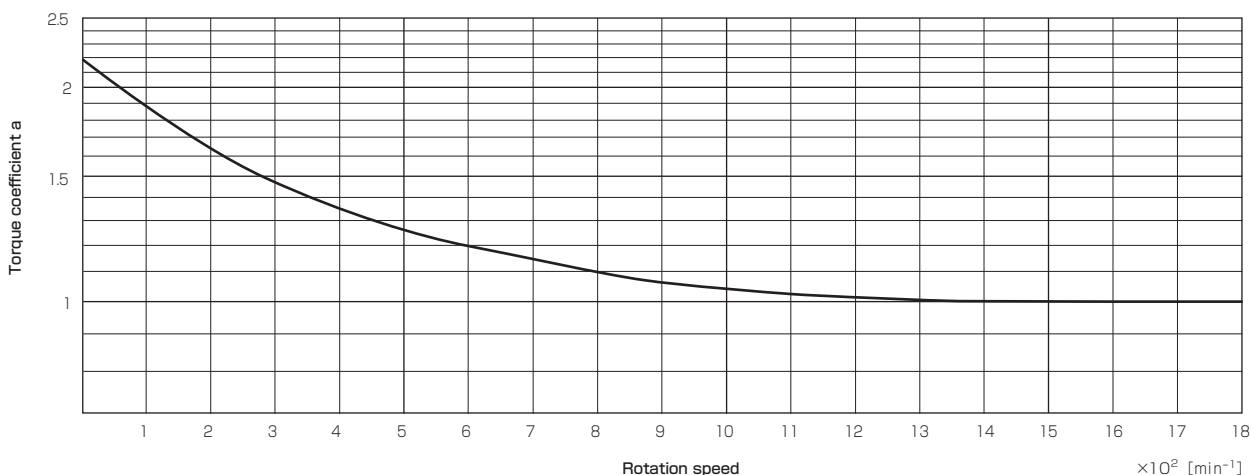

\* Use size 4X at a rotation speed equal to or less than 500 min<sup>-1</sup>.

## Standard Bore Diameter $\phi$ K

Model	Bore Drilling Standards	Nominal bore diameter	Standard bore diameter K [mm]																					
			8	10	11	12	14	15	16	18	19	20	22	24	25	28	30	32	35	38	40	42	45	
TT-1X-03	Old JIS standards (E9)	Blank	●	●	●	●																		
	JIS standards (H9)	H		●	●	●																		
	Motor standards	N																						
TT-2-03	Old JIS standards (E9)	Blank			●	●	●	●	●															
	JIS standards (H9)	H			●	●	●	●	●															
	Motor standards	N					●																	
TT-2X-03	Old JIS standards (E9)	Blank					●	●	●	●	●	●												
	JIS standards (H9)	H					●	●	●	●	●	●												
	Motor standards	N					●			●														
TT-3-03	Old JIS standards (E9)	Blank								●	●	●	●	●	●									
	JIS standards (H9)	H								●	●	●	●	●	●									
	Motor standards	N									●			●										
TT-3X-03	Old JIS standards (E9)	Blank								●	●	●	●	●	●									
	JIS standards (H9)	H								●	●	●	●	●	●									
	Motor standards	N									●			●										
TT-4X-03	Old JIS standards (E9)	Blank									●	●	●	●	●	●	●	●	●	●	●	●	●	●
	JIS standards (H9)	H									●	●	●	●	●	●	●	●	●	●	●	●	●	●
	Motor standards	N									●			●			●			●		●		●

\* There is no keyway for bore diameter  $\phi$ 8 mm. \* For the bore drilling standards, see P555.

### How to Place an Order

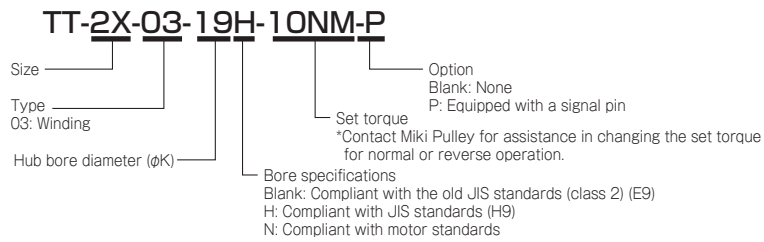

# Torque Limiters

## Options Signal Pin

Unattended or remotely controlled machines and equipment require equipment that detects an overload and automatically switches off the power or sounds a warning alarm.

An overload can be detected by connecting the signal pin to the torque tender. When an overload is detected, the input side and the output side are disconnected and the cam mechanism of the torque tender hub pushes the signal pin out in the radial direction. This can be used to switch off the power or sound a warning alarm.

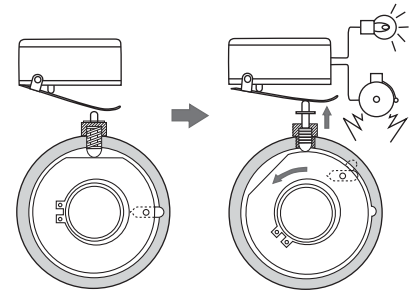

### Dimensions (TT-□-01-□-P)

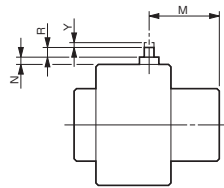

Unit [mm]

Size	M	Y	R	N
1X	24	1.5	6.5	5.5
2	29	2.5	5	4.5
2X	36	2.5	5	4.5
3	43	2.5	5	4.5
3X	42	2.5	5	4.5
4X	55	2.5	5	2

### Dimensions (TT-□-03-□-P)

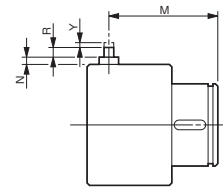

Unit [mm]

Size	M	Y	R	N
1X	47	1.5	6.5	5.5
2	56	2.5	5	4.5
2X	60	2.5	5	4.5
3	79	2.5	5	4.5
3X	114	2.5	5	4.5
4X	125	2.5	5	2

### How to Place an Order

**TT-2X-03-19H-10NM-P**

Size  
Type  
01 : Two-shaft butting  
03 : Winding

Option  
Blank: None  
P: Equipped with a signal pin  
Set torque (1500min<sup>-1</sup>)

\*Contact Miki Pulley for assistance in changing the set torque for normal or reverse operation.

Standard Hole-Drilling Standards

TT(O1)

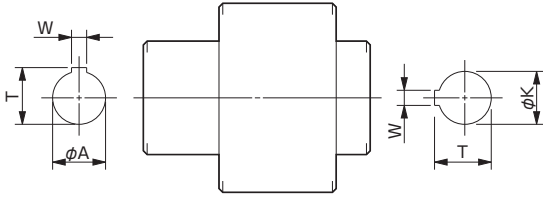

TT(O3)

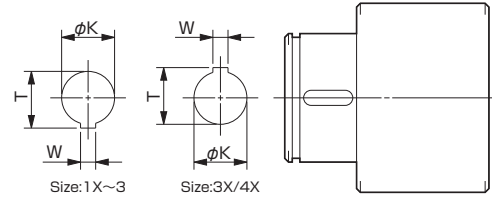

Size: 1X~3

Size: 3X/4X

Unit [mm]

Models compliant with the old JIS standard (class 2) JIS B 1301 1959				Models compliant with the new JIS standard (H9) JIS B 1301 1996				Models compliant with the motor standard JIS C 4210 2001			
Nominal bore diameter	Bore diameter [φA/φK]	Keyway width [W]	Keyway height [T]	Nominal bore diameter	Bore diameter [φA/φK]	Keyway width [W]	Keyway height [T]	Nominal bore diameter	Bore diameter [φA/φK]	Keyway width [W]	Keyway height [T]
	Tolerance H7	Tolerance E9	—		Tolerance H7	Tolerance H9	—		Tolerance G7	Tolerance H9	—
8	8 <sup>+0.015</sup> <sub>0</sub>	—	—	—	—	—	—	—	—	—	—
10	10 <sup>+0.015</sup> <sub>0</sub>	4 <sup>+0.050</sup> <sub>+0.020</sub>	11.5 <sup>+0.5</sup> <sub>0</sub>	10 H	10 <sup>+0.015</sup> <sub>0</sub>	4 <sup>+0.030</sup> <sub>0</sub>	11.8 <sup>+0.5</sup> <sub>0</sub>	—	—	—	—
11	11 <sup>+0.018</sup> <sub>0</sub>	4 <sup>+0.050</sup> <sub>+0.020</sub>	12.5 <sup>+0.5</sup> <sub>0</sub>	11 H	11 <sup>+0.018</sup> <sub>0</sub>	4 <sup>+0.030</sup> <sub>0</sub>	12.8 <sup>+0.5</sup> <sub>0</sub>	—	—	—	—
12	12 <sup>+0.018</sup> <sub>0</sub>	4 <sup>+0.050</sup> <sub>+0.020</sub>	13.5 <sup>+0.5</sup> <sub>0</sub>	12 H	12 <sup>+0.018</sup> <sub>0</sub>	4 <sup>+0.030</sup> <sub>0</sub>	13.8 <sup>+0.5</sup> <sub>0</sub>	—	—	—	—
14	14 <sup>+0.018</sup> <sub>0</sub>	5 <sup>+0.050</sup> <sub>+0.020</sub>	16.0 <sup>+0.5</sup> <sub>0</sub>	14 H	14 <sup>+0.018</sup> <sub>0</sub>	5 <sup>+0.030</sup> <sub>0</sub>	16.3 <sup>+0.5</sup> <sub>0</sub>	14 N	14 <sup>+0.024</sup> <sub>+0.006</sub>	5 <sup>+0.030</sup> <sub>0</sub>	16.0 <sup>+0.5</sup> <sub>0</sub>
15	15 <sup>+0.018</sup> <sub>0</sub>	5 <sup>+0.050</sup> <sub>+0.020</sub>	17.0 <sup>+0.5</sup> <sub>0</sub>	15 H	15 <sup>+0.018</sup> <sub>0</sub>	5 <sup>+0.030</sup> <sub>0</sub>	17.3 <sup>+0.5</sup> <sub>0</sub>	—	—	—	—
16	16 <sup>+0.018</sup> <sub>0</sub>	5 <sup>+0.050</sup> <sub>+0.020</sub>	18.0 <sup>+0.5</sup> <sub>0</sub>	16 H	16 <sup>+0.018</sup> <sub>0</sub>	5 <sup>+0.030</sup> <sub>0</sub>	18.3 <sup>+0.5</sup> <sub>0</sub>	—	—	—	—
18	18 <sup>+0.018</sup> <sub>0</sub>	5 <sup>+0.050</sup> <sub>+0.020</sub>	20.0 <sup>+0.5</sup> <sub>0</sub>	18 H	18 <sup>+0.018</sup> <sub>0</sub>	6 <sup>+0.030</sup> <sub>0</sub>	20.8 <sup>+0.5</sup> <sub>0</sub>	—	—	—	—
19	19 <sup>+0.021</sup> <sub>0</sub>	5 <sup>+0.050</sup> <sub>+0.020</sub>	21.0 <sup>+0.5</sup> <sub>0</sub>	19 H	19 <sup>+0.021</sup> <sub>0</sub>	6 <sup>+0.030</sup> <sub>0</sub>	21.8 <sup>+0.5</sup> <sub>0</sub>	19 N	19 <sup>+0.028</sup> <sub>+0.007</sub>	6 <sup>+0.030</sup> <sub>0</sub>	21.5 <sup>+0.5</sup> <sub>0</sub>
20	20 <sup>+0.021</sup> <sub>0</sub>	5 <sup>+0.050</sup> <sub>+0.020</sub>	22.0 <sup>+0.5</sup> <sub>0</sub>	20 H	20 <sup>+0.021</sup> <sub>0</sub>	6 <sup>+0.030</sup> <sub>0</sub>	22.8 <sup>+0.5</sup> <sub>0</sub>	—	—	—	—
22	22 <sup>+0.021</sup> <sub>0</sub>	7 <sup>+0.061</sup> <sub>+0.025</sub>	25.0 <sup>+0.5</sup> <sub>0</sub>	22 H	22 <sup>+0.021</sup> <sub>0</sub>	6 <sup>+0.030</sup> <sub>0</sub>	24.8 <sup>+0.5</sup> <sub>0</sub>	—	—	—	—
24	24 <sup>+0.021</sup> <sub>0</sub>	7 <sup>+0.061</sup> <sub>+0.025</sub>	27.0 <sup>+0.5</sup> <sub>0</sub>	24 H	24 <sup>+0.021</sup> <sub>0</sub>	8 <sup>+0.036</sup> <sub>0</sub>	27.3 <sup>+0.5</sup> <sub>0</sub>	24 N	24 <sup>+0.028</sup> <sub>+0.007</sub>	8 <sup>+0.036</sup> <sub>0</sub>	27.0 <sup>+0.5</sup> <sub>0</sub>
25	25 <sup>+0.021</sup> <sub>0</sub>	7 <sup>+0.061</sup> <sub>+0.025</sub>	28.0 <sup>+0.5</sup> <sub>0</sub>	25 H	25 <sup>+0.021</sup> <sub>0</sub>	8 <sup>+0.036</sup> <sub>0</sub>	28.3 <sup>+0.5</sup> <sub>0</sub>	—	—	—	—
28	28 <sup>+0.021</sup> <sub>0</sub>	7 <sup>+0.061</sup> <sub>+0.025</sub>	31.0 <sup>+0.5</sup> <sub>0</sub>	28 H	28 <sup>+0.021</sup> <sub>0</sub>	8 <sup>+0.036</sup> <sub>0</sub>	31.3 <sup>+0.5</sup> <sub>0</sub>	28 N	28 <sup>+0.028</sup> <sub>+0.007</sub>	8 <sup>+0.036</sup> <sub>0</sub>	31.0 <sup>+0.5</sup> <sub>0</sub>
30	30 <sup>+0.021</sup> <sub>0</sub>	7 <sup>+0.061</sup> <sub>+0.025</sub>	33.0 <sup>+0.5</sup> <sub>0</sub>	30 H	30 <sup>+0.021</sup> <sub>0</sub>	8 <sup>+0.036</sup> <sub>0</sub>	33.3 <sup>+0.5</sup> <sub>0</sub>	—	—	—	—
32	32 <sup>+0.025</sup> <sub>0</sub>	10 <sup>+0.061</sup> <sub>+0.025</sub>	35.5 <sup>+0.5</sup> <sub>0</sub>	32 H	32 <sup>+0.025</sup> <sub>0</sub>	10 <sup>+0.036</sup> <sub>0</sub>	35.3 <sup>+0.5</sup> <sub>0</sub>	—	—	—	—
35	35 <sup>+0.025</sup> <sub>0</sub>	10 <sup>+0.061</sup> <sub>+0.025</sub>	38.5 <sup>+0.5</sup> <sub>0</sub>	35 H	35 <sup>+0.025</sup> <sub>0</sub>	10 <sup>+0.036</sup> <sub>0</sub>	38.3 <sup>+0.5</sup> <sub>0</sub>	—	—	—	—
38	38 <sup>+0.025</sup> <sub>0</sub>	10 <sup>+0.061</sup> <sub>+0.025</sub>	41.5 <sup>+0.5</sup> <sub>0</sub>	38 H	38 <sup>+0.025</sup> <sub>0</sub>	10 <sup>+0.036</sup> <sub>0</sub>	41.3 <sup>+0.5</sup> <sub>0</sub>	38 N	38 <sup>+0.034</sup> <sub>+0.009</sub>	10 <sup>+0.036</sup> <sub>0</sub>	41.0 <sup>+0.5</sup> <sub>0</sub>
40	40 <sup>+0.025</sup> <sub>0</sub>	10 <sup>+0.061</sup> <sub>+0.025</sub>	43.5 <sup>+0.5</sup> <sub>0</sub>	40 H	40 <sup>+0.025</sup> <sub>0</sub>	12 <sup>+0.043</sup> <sub>0</sub>	43.3 <sup>+0.5</sup> <sub>0</sub>	—	—	—	—
42	42 <sup>+0.025</sup> <sub>0</sub>	12 <sup>+0.075</sup> <sub>+0.032</sub>	45.5 <sup>+0.5</sup> <sub>0</sub>	42 H	42 <sup>+0.025</sup> <sub>0</sub>	12 <sup>+0.043</sup> <sub>0</sub>	45.3 <sup>+0.5</sup> <sub>0</sub>	42 N	42 <sup>+0.034</sup> <sub>+0.009</sub>	12 <sup>+0.043</sup> <sub>0</sub>	45.0 <sup>+0.5</sup> <sub>0</sub>
45	45 <sup>+0.025</sup> <sub>0</sub>	12 <sup>+0.075</sup> <sub>+0.032</sub>	48.5 <sup>+0.5</sup> <sub>0</sub>	45 H	45 <sup>+0.025</sup> <sub>0</sub>	14 <sup>+0.043</sup> <sub>0</sub>	48.8 <sup>+0.5</sup> <sub>0</sub>	—	—	—	—
48	48 <sup>+0.025</sup> <sub>0</sub>	12 <sup>+0.075</sup> <sub>+0.032</sub>	51.5 <sup>+0.5</sup> <sub>0</sub>	48 H	48 <sup>+0.025</sup> <sub>0</sub>	14 <sup>+0.043</sup> <sub>0</sub>	51.8 <sup>+0.5</sup> <sub>0</sub>	48 N	48 <sup>+0.034</sup> <sub>+0.009</sub>	14 <sup>+0.043</sup> <sub>0</sub>	51.5 <sup>+0.5</sup> <sub>0</sub>
50	50 <sup>+0.025</sup> <sub>0</sub>	12 <sup>+0.075</sup> <sub>+0.032</sub>	53.5 <sup>+0.5</sup> <sub>0</sub>	50 H	50 <sup>+0.025</sup> <sub>0</sub>	14 <sup>+0.043</sup> <sub>0</sub>	53.8 <sup>+0.5</sup> <sub>0</sub>	—	—	—	—

NOTE

- Set screws are included with the product.
- For standard dimensions for bore drilling other than those given here, contact Miki Pulley. (A bore may not be able to be drilled for some hub sizes.)

## Torque Limiters

### Items Checked for Design Purposes

#### Precautions for Handling

- (1) Operating temperature range is  $-25^{\circ}\text{C}$  -  $120^{\circ}\text{C}$ . Do not use where exposed to corrosive gas or chemicals. Not waterproof; do not use where exposed directly to water.
- (2) The product is designed only as an overload protection device where set torque values vary by  $\pm 20\%$ , and is not designed to detect torque with accuracy. Never use as a torque detection device, as this will be a cause of problems.
- (3) Products are shipped with all torque springs inserted at our factory. If the set torque needs to be changed, contact our sales office. Do not disassemble or replace springs yourself.

#### Mounting

- (1) Touching (hands, fingers) the product while it is operating may cause injury. Always place a safety cover to prevent a safety hazard.
- (2) If the overload protection device is activated, the driver and follower sides of the product completely separate. Always place a safety brake or other safety mechanism to prevent a safety hazard.
- (3) Continuing to operate with the overload protection mechanism having activated will allow the product to overheat. Operation while overheated may damage the product and affect the device. Always use a detection device, and immediately cease operation of the device if the overload protection mechanism has activated.
- (4) Backlash may be experienced. Attention is required depending on the application.
- (5) TT(O1) type is two-shaft butting. Ensure that the permissible mounting misalignment of the two shafts is within 0.2 mm parallel and  $0.5^{\circ}$  angular.

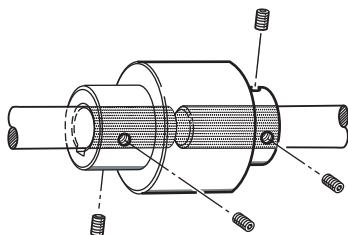

- (6) TT(O3) type is winding. A shaft inserts in its inner circumference, and a pulley, sprocket, etc. attaches to the housing's outer circumference.

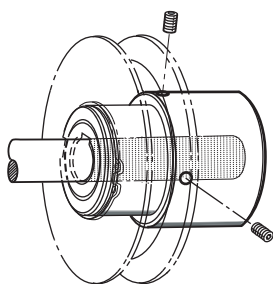

#### Operation precautions

- (1) Never use beyond the designed rotation speeds. Operation at rotation speeds other than those for which it was designed may prevent the driver and follower ends from separating at a load you want the overload protection device to activate at, or may cause the driver and follower to separate at a load less than that at which you want the overload protection device to activate at.
- (2) If the torque tender has operated due to an overload, immediately stop operation. Check to make sure that the main power of the equipment is switched off and then remove the cause of the overload on the driven side. To recover, apply a torque of more than 55% of the set torque at  $1500\text{ min}^{-1}$  to the driven side, and then manually rotate the driving side to connect the driving side and the driven side. Before restarting operation, be sure to perform a startup inspection and test run.

#### Optional Signal Pin

- (1) Standard products cannot be modified to accommodate a signal pin. Indicate any requirement for a signal pin beforehand.
- (2) When using a signal pin, make sure that input is from the housing.

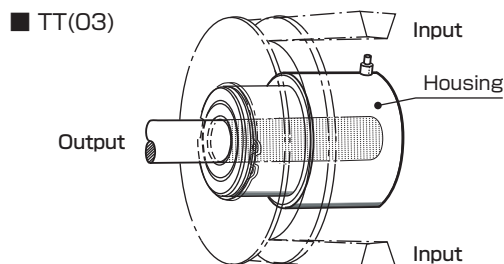
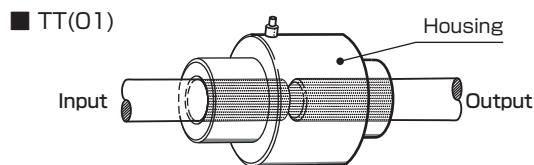

- (3) Be sure to use two detection switches, distanced from each other at least  $120^{\circ}$  in the direction of rotation. Detection may not be possible with a switch only at one location.
- (4) While attention is given to the quality of the signal pin, it is recommended to install detection equipment in addition to the signal pin as a precaution.

#### Individual torque settings for normal and reverse rotation (special specifications)

Setting individual torque springs for normal and reverse rotation enables setting torque to be changed for normal and reverse operation. However, as the internal spring settings affect each other, such an implementation cannot be achieved simply using springs with a nominal setting. For products requiring individual torque settings for normal and reverse rotation, contact Miki Pulley.

## Selection

### Determining the Operation Torque Value

Determine the operation torque value  $T$  of the torque tender based on the mechanical strength, load, and other conditions.

If the operation torque cannot be determined based on the above conditions, it can be calculated with an expression of the rated output of the drive unit and the rotation speed of the shaft to which the torque tender is connected.

$$T = K \times \frac{9550 \times P}{n}$$

T: Operation torque [N · m]  
K: Service factor  
P: Drive unit rated output [kW]  
n: Torque tender rotation speed [min<sup>-1</sup>]

### Service Factor K

Directly connected to the motor	2.0 ~ 2.5
After changing speed	1.75 ~ 2.0
After deceleration	1.25 ~ 1.50
Rotation speed 25 min <sup>-1</sup> or less	1.25

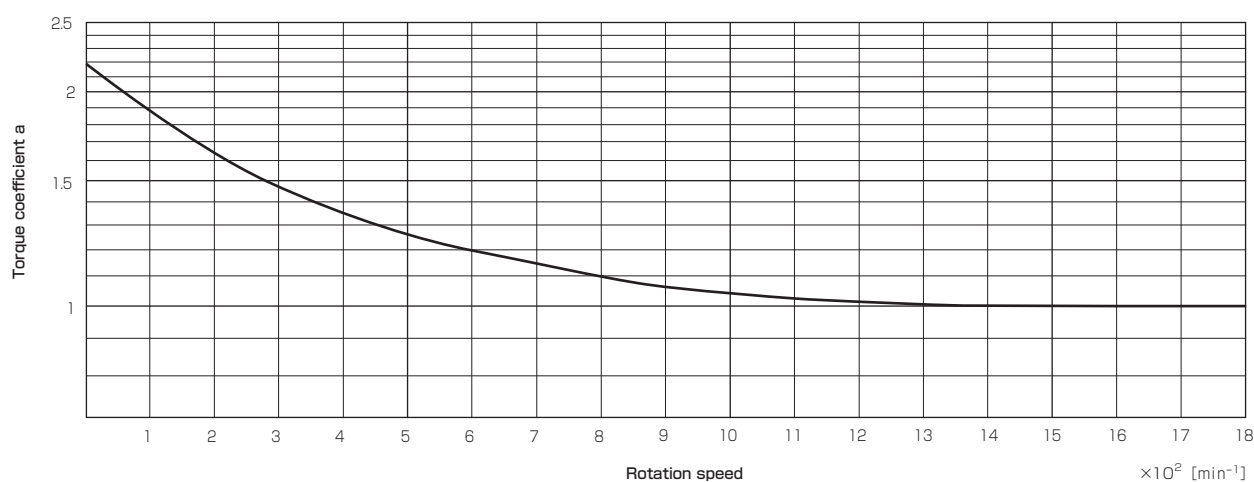

\* Use size 4X at a rotation speed equal to or less than 500 min<sup>-1</sup>.

### Selecting the Model and Set Torque

The operation torque changes as shown in the figure below as a result of the characteristics of the torque tender.

The set torque values of the torque tender are those when the rotation speed is 1500 min<sup>-1</sup>. Accordingly, you need to read torque coefficient  $a$  at the rotation speed of the shaft to which the torque tender is connected from the figure below, and convert it to the set torque at 1500 min<sup>-1</sup> using the following expression.

$$T_s = \frac{T}{a}$$

T: Operation torque [N · m]

a: Torque coefficient

T<sub>s</sub>: Set torque at 1500 min<sup>-1</sup> [N · m]

From the specification table, select the size whose set torque value is closest to T<sub>s</sub> that was calculated with the expression above.

COUPLINGS

ETP BUSHINGS

ELECTROMAGNETIC  
CLUTCHES & BRAKESSPEED CHANGERS  
& REDUCERS

INVERTERS

LINEAR SHAFT DRIVES

TORQUE LIMITERS

ROSTA

MODELS

TT