



Koganei Clean System products provide complete support for the maintenance of a clean environment inside the cleanroom.

Koganei Clean System products meet the needs of the ultra-clean production environment. In everything from actuators and valves to air preparation and auxiliary equipment, anti-corrosion materials processing and other Koganei-developed design concepts serve to prevent particle contamination within the cleanroom. These perfectly designed mechanisms, which resolve even the slightest leaks to the outside during operations, have already won a high level of reliability.

Koganei Cleanliness

There is currently no standard in JIS or elsewhere for methods of evaluating cleanliness for pneumatic equipment in the cleanroom specifications. Therefore, to measure the effects of cleanroom contamination by pneumatic equipment, Koganei has decided to use “number of particles generated per 10 operations,” rather than particle density. Koganei has also developed classifications for application classes in cleanroom, based on JIS and other upper limit density tables, and on the company’s own experience.

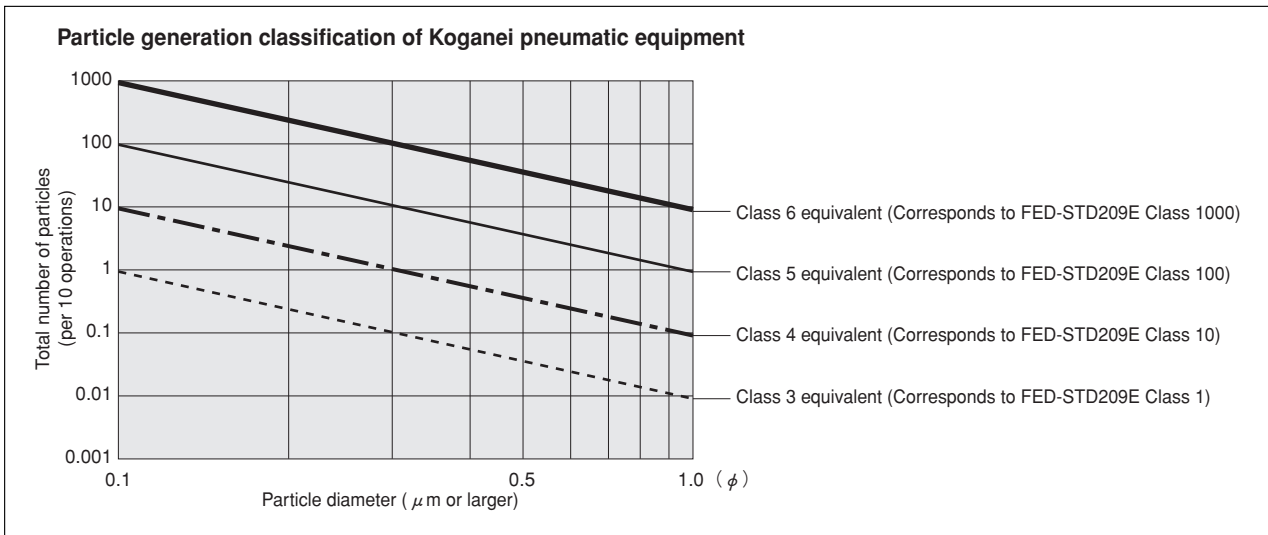

- Remarks:
1. In the above table, product performance in terms of the number of particles generated per 10 operations is expressed as the upper limit of particles corresponding to the equivalent JIS or ISO class.
 2. In the above table, values in the JIS, ISO, and FED-STD upper limit density tables are calculated as upper density per liter.
 3. The classes shown are clean levels as classified in JIS and ISO.

From the above definitions, the Koganei clean level classes can be viewed as the level of average contamination per liter of surrounding air over a period of 10 operations in cleanroom. Air ventilation in cleanrooms is usually faster than 1 cycle per minute, and clean volumetric capacity is usually larger than 1 liter, which should provide a sufficient safety margin in practice.

Caution: The above conclusions are based on an ideal situation in which air ventilation is being implemented. For specific cases where air ventilation is not ensured, caution is needed since the clean classes cannot be maintained.

The clean system diagrams shown here are for Class 5 equivalent products. For Class 4 or Class 3 equivalent products, consult us.

Evaluations of Cleanliness

Koganei has therefore specified its in-house measurement methods, to conduct evaluations on the cleanroom rating.

The number of particles of the Air Cylinder Cleanroom Specification is measured as shown in the method below.

1. Measurement conditions

1-1 Test circuit: Figure 1 (no suction), Figure 2 (with suction)

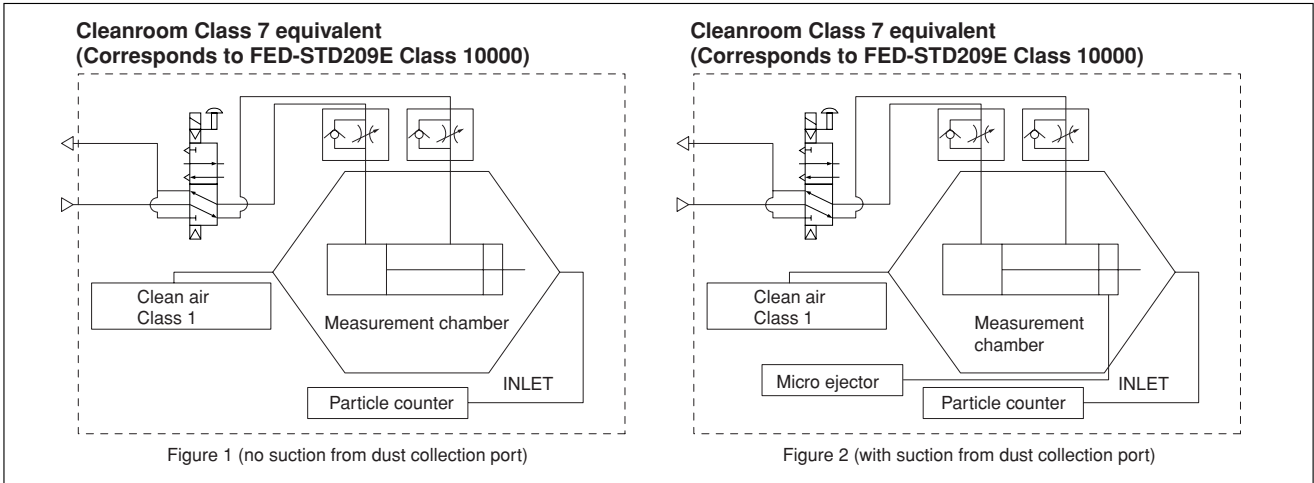

1-2 Operating conditions of tested cylinder

- Operating frequency: 1Hz
- Average speed: 500mm/s [20in./sec.]
- Applied pressure: 0.5MPa [73psi.]
- Suction condition: Microejector ME05, Primary side: 0.5MPa [73psi.] applied, Tube: $\phi 6$ [0.236in.]
- Mounting direction: Vertical
- Chamber volume: 8.3 ℓ [0.293ft.³]

2. Particle counter

- Manufacturer/model: RION/KM20
- Suction flow rate: 28.3 ℓ /min [1ft.³/min.]
- Particle diameter: 0.1 μm , 0.2 μm , 0.3 μm , 0.5 μm , 0.7 μm , 1.0 μm

3. Measurement method

- 3-1 Confirmation of number of particles in the measurement system
Under the conditions in the above 1 and 2, using a particle counter to measure the sample for 9 minutes without operating the measurement sample, and confirmed the measured number of particle is 1 piece or less.
- 3-2 Measurement under operation
Under the conditions in the above 1 and 2, operating the measurement sample for 36 minutes, and measured the total values in the latter half of 18 minutes test.
- 3-3 Reconfirmation
Performed the measurement in 3-1 again, to reconfirm the number of particles in the measurement system.

4. Measurement results

● Cleanroom specification

Jig Cylinder (no suction from dust collection port)

Particle generation over 1 million operations (CS-CDA16 \times 30)

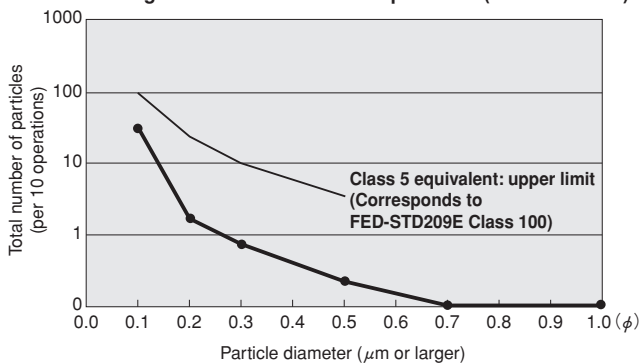

● Cleanroom specification

Slim Cylinder (with suction from dust collection port)

Particle generation over 1 million operations (CS-DA20 \times 100)

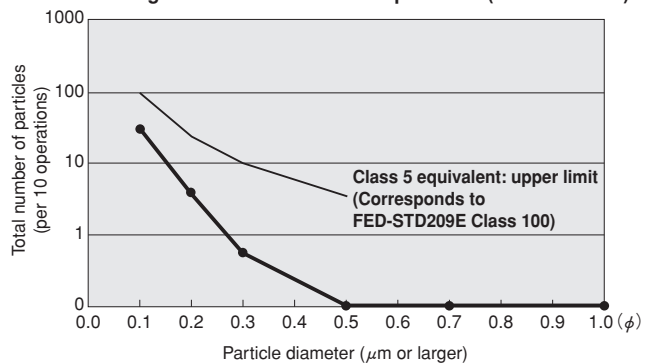

For “safety precautions” listed in the Clean System Product Drawings, see the materials below.

- For actuators, see “Safety Precautions” on p. 45 of the Actuators General Catalog .
- For valves, see “Safety Precautions” on p. 31 of the Valves General Catalog.
- For air treatment and auxiliary equipment, see “Safety Precautions” on p.31 of the General Catalog of Air Treatment, Auxiliary, Vacuum.

Symbol



Specifications

		Bore size mm [in.]	6 [0.236]
Item			
Media	Air		
Mounting type	Side mount		
Operating pressure range	MPa [psi.]	0.3~0.7 [44~102]	
Proof pressure	MPa [psi.]	1.03 [149]	
Operating temperature range	°C [°F]	0~60 [32~140]	
Operating speed range	mm/s [in./sec.]	100~300 [3.9~11.8]	
Cushion	None		
Lubrication	Not required		
Non-rotating accuracy	±0.45°		
Port size	Supply and exhaust port	M5×0.8	
	Dust collection port	M5×0.8	

Bore Size and Stroke

mm [in.]		
Bore size	Standard strokes	Maximum available stroke
6 [0.236]	10, 20, 30, 40, 50	70

Note: Consult us for delivery of cylinders with strokes exceeding the standard.

Order Codes

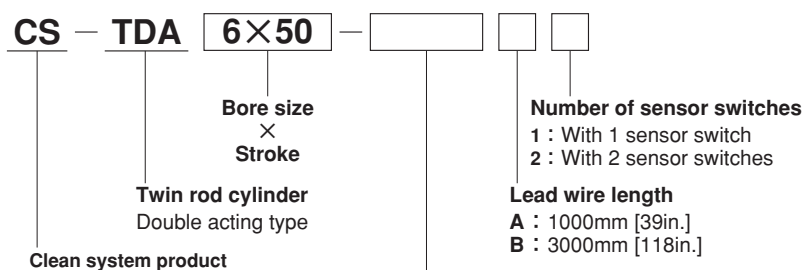

Sensor switch

- Blank** : Without sensor switch
 - CS5T** : 2-lead wire Reed switch type without indicator lamp (DC5~28V, AC85~115V)
 - CS11T** : 2-lead wire Reed switch type with indicator lamp (DC10~28V)
 - ZC130** : 2-lead wire Solid state type with indicator lamp (DC10~28V)
 - ZC153** : 2-lead wire Solid state type with indicator lamp (DC4.5~28V)
- For details of sensor switches, see p.111 ~ 121.

- Remarks: 1. In the twin rod cylinder, a magnet for sensor switch is built-in.
2. Two sensor holders (one for the A surface and one for the B surface) come with 1 sensor switch.

Mass

Bore size mm [in.]		Zero stroke mass ^{Note1}	Additional mass	
			Additional mass of each 10mm [0.394in.] stroke	Mass of 1 sensor switch ^{Note2} CS5T,CS11T,ZC130,ZC153
6 [0.236]	Standard specification	68 [2.40]	12 [0.42]	A : 20 [0.71] B : 50 [1.76]

- Notes: 1. The above table is for the standard strokes.
2. There are 2 types of sensor switch lead wire lengths.
A: 1000mm [39in.], B: 3000mm [118in.]

Calculation example: The mass for bore size of 20mm and stroke of 50mm with 2 sensor switches (**ZC130**),
68+(12×5)+(20×2)=168g [5.93oz.]

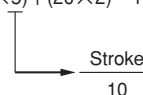

Inner Construction and Major Parts

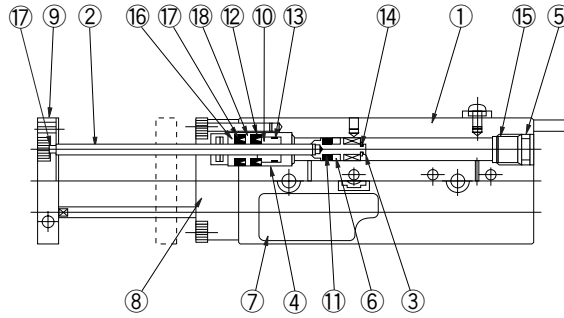

Major Parts and Materials

No.	Parts	Materials
①	Cylinder body	Aluminum alloy (anodized)
②	Piston	Aluminum alloy (chromic acid anodic oxide coating)
③	Cover	Aluminum alloy (anodized)
④	Wear ring	Plastic
⑤	Piston rod	Steel (chrome plated)
⑥	Housing gasket	Synthetic rubber (NBR)
⑦	Housing	Aluminum alloy (chromic acid anodic oxide coating)
⑧	Seal holder	Aluminum alloy
⑨	Rod bushing	Plastic
⑩	Piston seal	Synthetic rubber (NBR)
⑪	Plug	Aluminum alloy (anodized)
⑫	Magnet	Plastic magnet
⑬	E-ring	Stainless steel
⑭	Washer	Steel (nickel plated)
⑮	End plate	Mild steel (nickel plated)
⑯	Rod seal	Synthetic rubber
⑰	Dust leak prevention seal	
⑱	Plug gasket	

Seals

Parts	Rod seal	Piston seal	Plug gasket	Housing gasket	Dust leak prevention seal
Q'ty	2	2	2	2	2
Bore mm	6	6	6	6	6
	MYR-4	PWP-6	1.5×1.5	1×6	MYR-4

Dimensions mm [in.]

CS-TDA6 ×

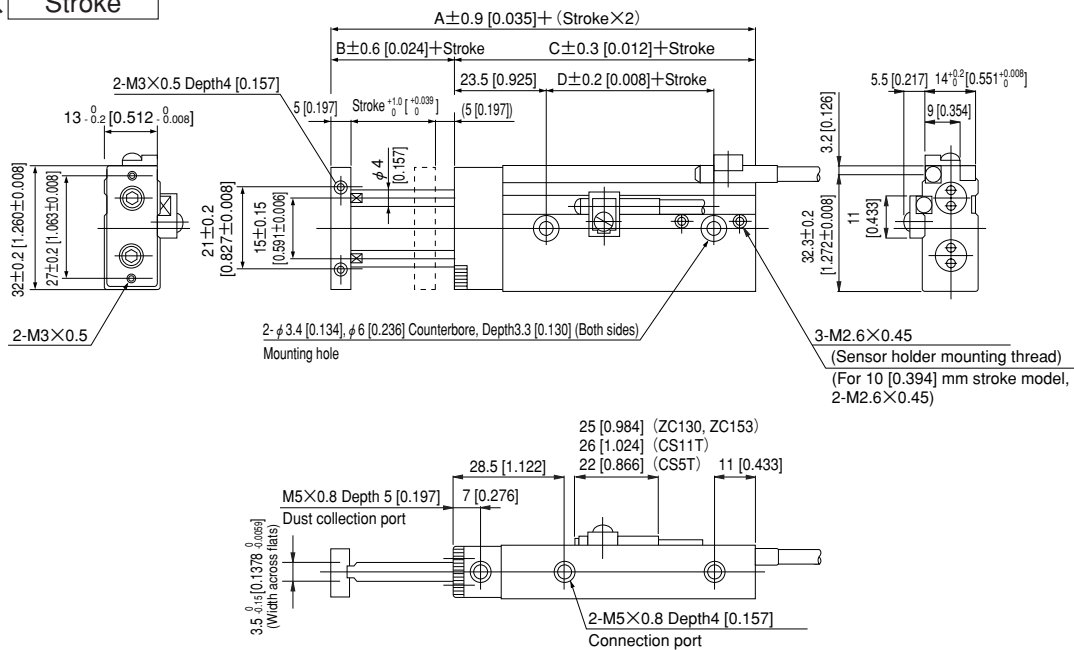

Bore	Code	A	B	C	D
6		61 [2.402]	10 [0.394]	51 [2.008]	13 [0.512]

Note: The counterbore depth is measured from the upper surface of the body.

TWIN ROD CYLINDERS $\phi 6$

Sensor Switches

Order Codes

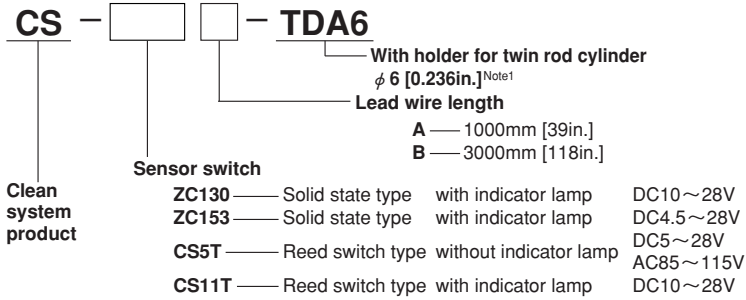

Order code of sensor holder only

C1-TDA6^{Note2}

- Notes: 1. Two sensor holders (one for the A, C surface and one for the B surface) come with 1 sensor switch.
 2. One set consists of 2 sensor holders (one each for the A, C surface and for the B surface).

Remark : For the mounting surfaces, see p.90.

For details of sensor switches, see p.111~121.

Sensor Switch Operating Range, Response Differential, and Maximum Sensing Location

Operating range: l

The distance the piston travels in one direction, while the switch is in the ON position.

Response differential: C

The distance between the point where the piston turns the switch ON and the point where the switch is turned OFF as the piston travels in the opposite direction.

CS5T□			CS11T□			ZC130□, ZC153□		
Operating range	Response differential	Maximum sensing location	Operating range	Response differential	Maximum sensing location	Operating range	Response differential	Maximum sensing location
5~7 [0.197~0.276]	1.3 [0.051] or less	7 [0.276]	5~7 [0.197~0.276]	1.3 [0.051] or less	10.5 [0.413]	2~3 [0.079~0.118]	0.3 [0.012] or less	8.5 [0.335]

Note: The maximum sensing location is the distance from the end of the switch opposite to the lead wire.

Remark: The above table shows reference values.

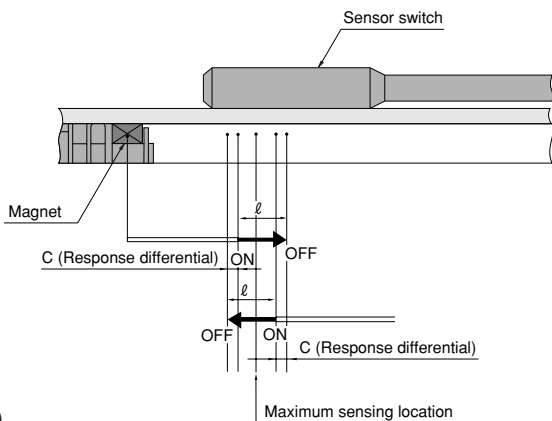

Minimum Cylinder Strokes When Using Sensor Switches

Type of sensor switch	2 pcs. mounting			1 pc. mounting
	1-surface mounting		2-surface mounting	
	One groove on each A surface and B surface	Two grooves on B surface		
CS □ T □	40 [1.575]	10 [0.394]	10 [0.394]	10 [0.394]
ZC □□	40 [1.575]	10 [0.394]	10 [0.394]	10 [0.394]

Remark : For the mounting surfaces, see p.90.

Moving Sensor Switch

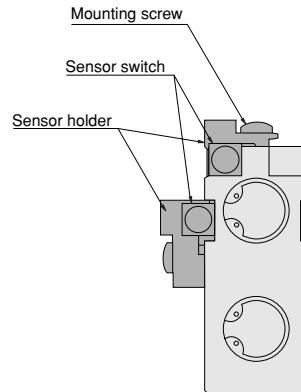

The diagram shows a view from the end plate side.

- Loosening mounting screw allows the sensor switch to be moved freely in the cylinder's axial direction.
- Tighten the mounting screw with a tightening torque of 0.3N·m [2.7in·lbf] or less.

Sensor Switch Mounting Surface

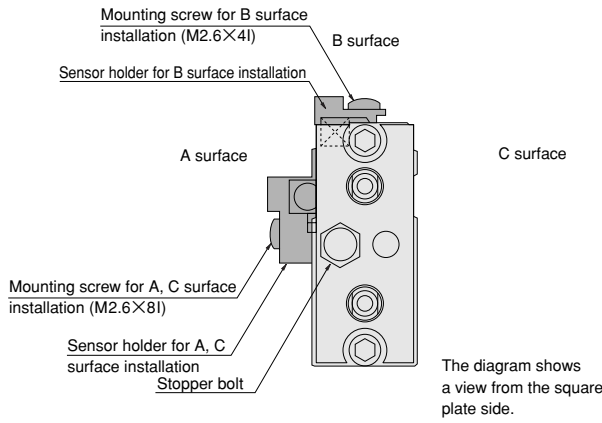

Caution when mounting

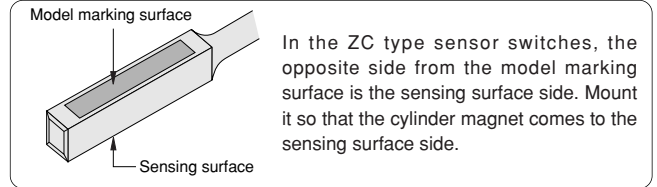

- Mounting on either 1 or 2 surfaces of the A, B, or C surfaces allows detection of the rod side and head side stroke end.
- Since 2 sensor holders and 2 mounting screws (one for the A, C surface and one for the B surface) are provided for each sensor switch, use them in accordance with the required mounting surface.

Mounting Location of End of Stroke Detection Sensor Switch

- When the sensor switch is mounted in the locations shown below (the figures in the tables are reference values), the magnet comes to the maximum sensing location of the sensor switch at the end of the stroke.

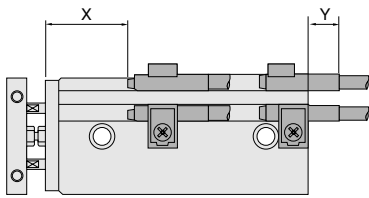

Mounting location	Sensor switch type		
	CS5T □	CS11T □	ZC130 □, ZC153 □
X	23 [0.906]	19.5 [0.768]	22 [0.866]
Y	6 [0.236]	6.5 [0.256]	8 [0.315]

Remark: Mount the sensor switch so that the surface showing the model marking faces up.

Dimensions of Sensor Switch mm [in.]

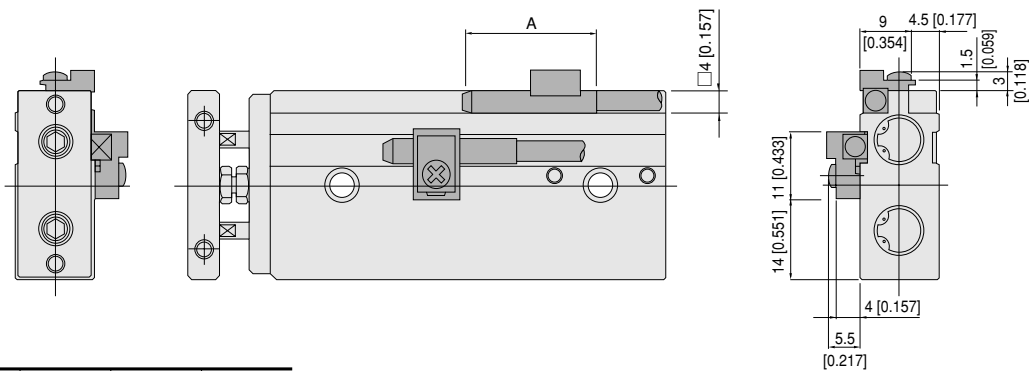

Sensor switch Code	CS5T □	CS11T □	ZC130 □	ZC153 □
A	22 [0.866]	26 [1.024]	25 [0.984]	



Koganei Clean System products provide complete support for the maintenance of a clean environment inside the cleanroom.

Koganei Clean System products meet the needs of the ultra-clean production environment. In everything from actuators and valves to air preparation and auxiliary equipment, anti-corrosion materials processing and other Koganei-developed design concepts serve to prevent particle contamination within the cleanroom. These perfectly designed mechanisms, which resolve even the slightest leaks to the outside during operations, have already won a high level of reliability.

Koganei Cleanliness

There is currently no standard in JIS or elsewhere for methods of evaluating cleanliness for pneumatic equipment in the cleanroom specifications. Therefore, to measure the effects of cleanroom contamination by pneumatic equipment, Koganei has decided to use “number of particles generated per 10 operations,” rather than particle density. Koganei has also developed classifications for application classes in cleanroom, based on JIS and other upper limit density tables, and on the company’s own experience.

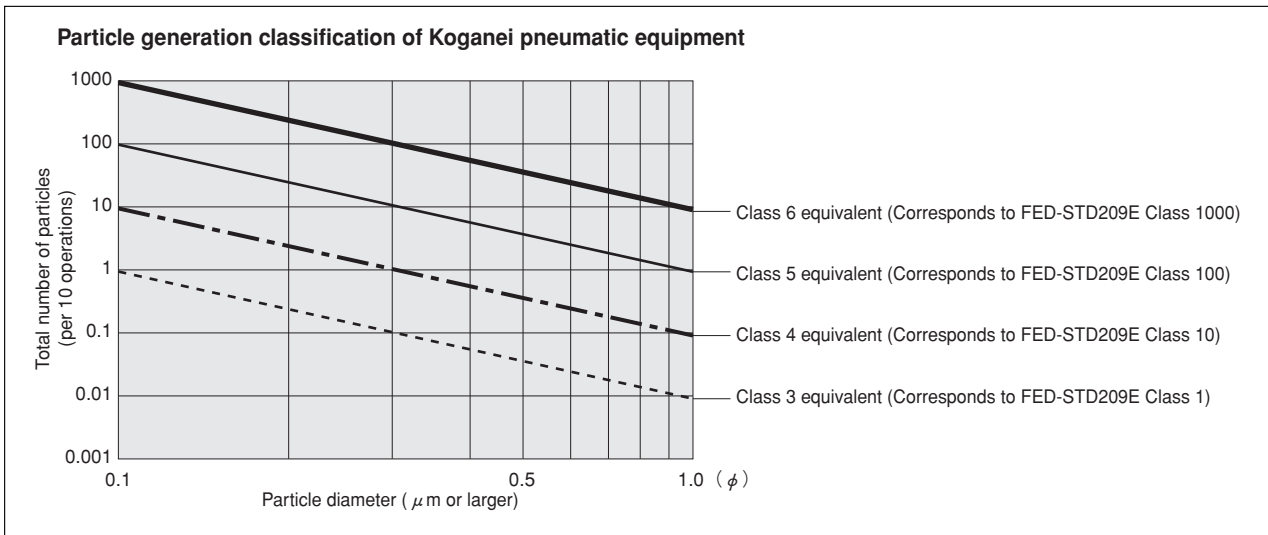

- Remarks:
1. In the above table, product performance in terms of the number of particles generated per 10 operations is expressed as the upper limit of particles corresponding to the equivalent JIS or ISO class.
 2. In the above table, values in the JIS, ISO, and FED-STD upper limit density tables are calculated as upper density per liter.
 3. The classes shown are clean levels as classified in JIS and ISO.

From the above definitions, the Koganei clean level classes can be viewed as the level of average contamination per liter of surrounding air over a period of 10 operations in cleanroom. Air ventilation in cleanrooms is usually faster than 1 cycle per minute, and clean volumetric capacity is usually larger than 1 liter, which should provide a sufficient safety margin in practice.

Caution: The above conclusions are based on an ideal situation in which air ventilation is being implemented. For specific cases where air ventilation is not ensured, caution is needed since the clean classes cannot be maintained.

The clean system diagrams shown here are for Class 5 equivalent products. For Class 4 or Class 3 equivalent products, consult us.

Evaluations of Cleanliness

Koganei has therefore specified its in-house measurement methods, to conduct evaluations on the cleanroom rating.

The number of particles of the Air Cylinder Cleanroom Specification is measured as shown in the method below.

1. Measurement conditions

1-1 Test circuit: Figure 1 (no suction), Figure 2 (with suction)

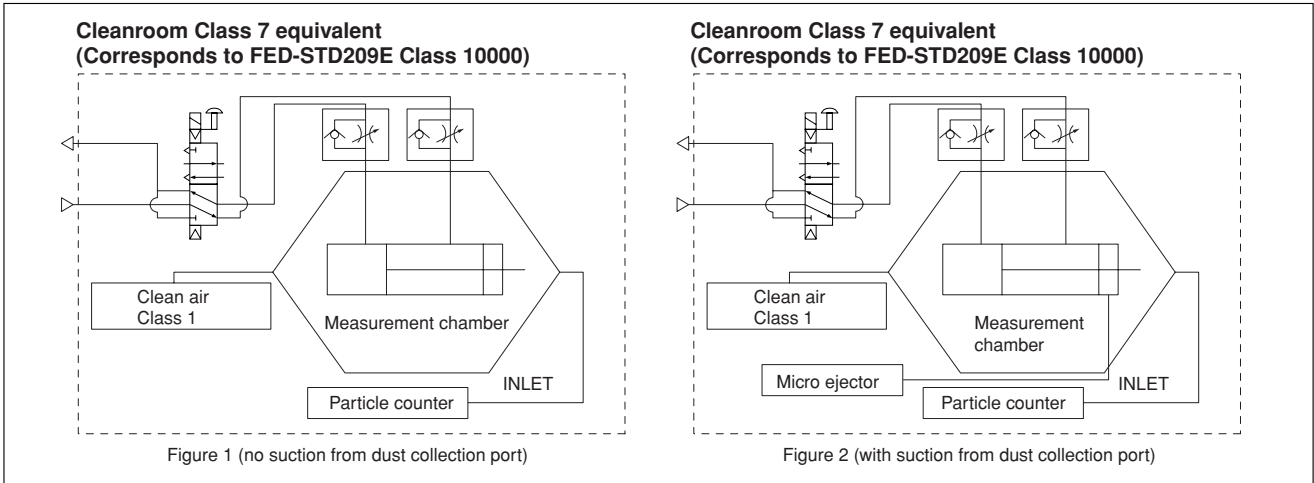

1-2 Operating conditions of tested cylinder

- Operating frequency: 1Hz
- Average speed: 500mm/s [20in./sec.]
- Applied pressure: 0.5MPa [73psi.]
- Suction condition: Microejector ME05, Primary side: 0.5MPa [73psi.] applied, Tube: $\phi 6$ [0.236in.]
- Mounting direction: Vertical
- Chamber volume: 8.3 ℓ [0.293ft.³]

2. Particle counter

- Manufacturer/model: RION/KM20
- Suction flow rate: 28.3 ℓ /min [1ft.³/min.]
- Particle diameter: 0.1 μm , 0.2 μm , 0.3 μm , 0.5 μm , 0.7 μm , 1.0 μm

3. Measurement method

- 3-1 Confirmation of number of particles in the measurement system
Under the conditions in the above 1 and 2, using a particle counter to measure the sample for 9 minutes without operating the measurement sample, and confirmed the measured number of particle is 1 piece or less.
- 3-2 Measurement under operation
Under the conditions in the above 1 and 2, operating the measurement sample for 36 minutes, and measured the total values in the latter half of 18 minutes test.
- 3-3 Reconfirmation
Performed the measurement in 3-1 again, to reconfirm the number of particles in the measurement system.

4. Measurement results

● Cleanroom specification

Jig Cylinder (no suction from dust collection port)

Particle generation over 1 million operations (CS-CDA16 \times 30)

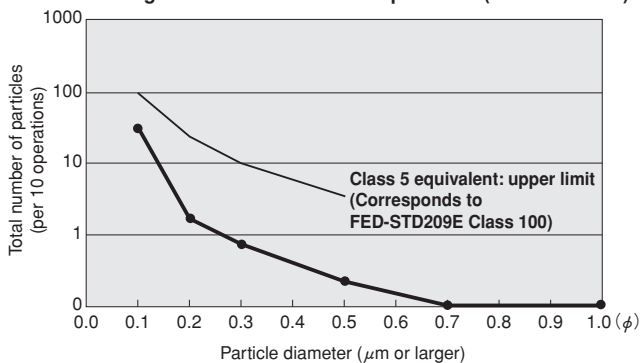

● Cleanroom specification

Slim Cylinder (with suction from dust collection port)

Particle generation over 1 million operations (CS-DA20 \times 100)

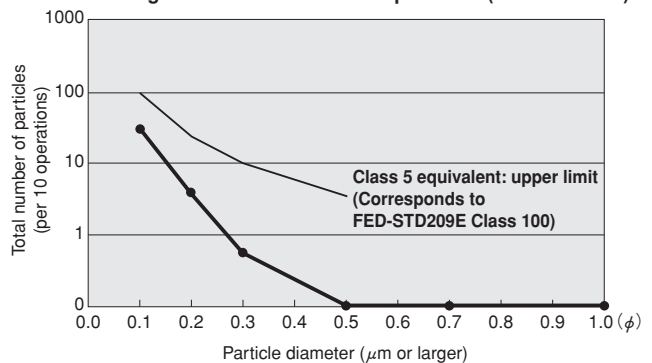

For “safety precautions” listed in the Clean System Product Drawings, see the materials below.

- For actuators, see “Safety Precautions” on p. 45 of the Actuators General Catalog .
- For valves, see “Safety Precautions” on p. 31 of the Valves General Catalog.
- For air treatment and auxiliary equipment, see “Safety Precautions” on p.31 of the General Catalog of Air Treatment, Auxiliary, Vacuum.

TWIN ROD CYLINDERS B SERIES

Double Acting Type

Symbol

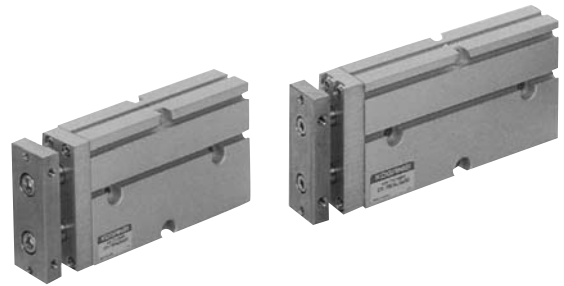
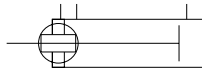

Specifications

Item	Bore size mm [in.]				
	10 [0.394]	16 [0.630]	20 [0.787]	25 [0.984]	32 [1.260]
Operating type	Air				
Media	Side mount				
Operating pressure range	MPa [psi.]	0.15~0.7 [22~102]		0.1~0.7 [15~102]	
Proof pressure	MPa [psi.]	1.03 [149]			
Operating temperature range	°C [°F]	0~60 [32~140]			
Operating speed range	mm/s [in./sec.]	100~300 [3.9~11.8]			
Cushion	None	Rubber bumper			
Lubrication	Not required				
Non-rotating accuracy	±0.4°		±0.3°		
Port size	Supply port	M5×0.8			Rc1/8
	Dust collection port	M5×0.8			

Bore Size and Stroke

Bore size	mm [in.]	
	Standard strokes	Maximum available stroke
10 [0.394]	10, 20, 30, 40, 50, 60, 70	140
16 [0.630]	10, 20, 30, 40, 50, 60, 70, 80, 90, 100	200
20 [0.787]	10, 20, 30, 40, 50, 60, 70, 80, 90, 100	200
25 [0.984]	10, 20, 30, 40, 50, 60, 70, 80, 90, 100	200
32 [1.260]	10, 20, 30, 40, 50, 60, 70, 80, 90, 100	200

Remark: Consult us for delivery of cylinders with strokes exceeding the standard.

Order Codes

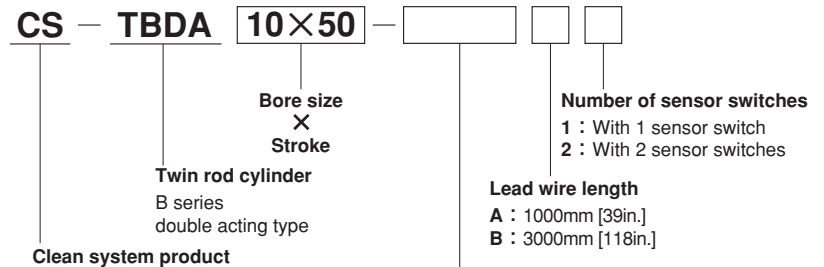

Sensor switch

Blank : Without sensor switch

ZE135 : 2-lead wire, Solid state type with indicator lamp DC10~28V Horizontal lead wire

ZE235 : 2-lead wire, Solid state type with indicator lamp DC10~28V Vertical lead wire

ZE155 : 3-lead wire, Solid state type with indicator lamp DC4.5~28V Horizontal lead wire

ZE255 : 3-lead wire, Solid state type with indicator lamp DC4.5~28V Vertical lead wire

ZE101 : 2-lead wire, Reed switch type without indicator lamp DC5~28V, AC85~115 Horizontal lead wire

ZE201 : 2-lead wire, Reed switch type without indicator lamp DC5~28V, AC85~115 Vertical lead wire

ZE102 : 2-lead wire, Reed switch type with indicator lamp DC10~28V, AC85~115V Horizontal lead wire

ZE202 : 2-lead wire, Reed switch type with indicator lamp DC10~28V, AC85~115V Vertical lead wire

● For details of sensor switches, see p.111~121.

Remark: In the standard cylinder, the magnet for sensor switch is built-in.

Inner Construction and Major Parts

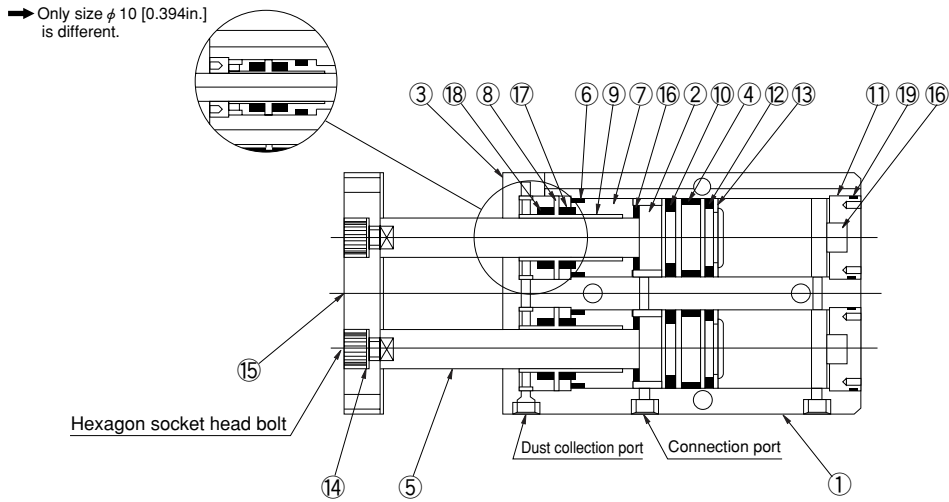

Major Parts and Materials

No.	Parts	Materials
①	Cylinder body	Aluminum alloy (anodized)
②	Piston	Aluminum alloy (chromic acid anodic oxide coating)
③	Cover	Aluminum alloy (anodized)
④	Wear ring	Plastic
⑤	Piston rod	Steel (chrome plated)
⑥	Housing gasket	Synthetic rubber (NBR)
⑦	Housing	Aluminum alloy (chromic acid anodic oxide coating)
⑧	Seal holder	Mild steel (nickel plated)
⑨	Rod bushing	Plastic
⑩	Piston seal	Synthetic rubber (NBR)
⑪	Plug	Aluminum alloy (anodized)
⑫	Magnet	Plastic magnet
⑬	E-ring	Stainless steel
⑭	Washer	Steel (nickel plated)
⑮	End plate	Mild steel (nickel plated)
⑯	Bumper	φ 10, 16, 20, 25 : Synthetic rubber, φ 32 : Urethane
⑰	Rod seal	Synthetic rubber (NBR)
⑱	Dust leak prevention seal	
⑲	Plug gasket	

Seals

Parts	Rod seal	Piston seal	Plug gasket	Housing gasket	Dust leak prevention seal
<i>Bore mm</i> Q'ty	2	2	2	2	2
10	PIU-6	PWP-10	1.5×9	1.5×9	PIU-6
16	PIU-8	PWP-16	1.5×15	1.5×13	PIU-8
20	PIU-10	PWP-20	1.5×19.5	1.5×17	PIU-10
25	PIU-12	PWP-25	1.5×23	1.5×22	PIU-12
32	PIU-16	PWP-32	2×31.5	2×28.5	PIU-16

Mass

Bore size mm [in.]		Zero stroke mass ^{Note1}	Additional mass		
			Additional mass of each 10mm [0.394in.] stroke	Mass of 1 sensor switch ^{Note2}	
				ZE□□□A	ZE□□□B
10 [0.394]	Standard specification	124 [4.37]	18 [0.63]	15 [0.53]	35 [1.23]
16 [0.630]		235 [8.29]	27 [0.95]		
20 [0.787]		393 [13.86]	36 [1.27]		
25 [0.984]		584 [20.60]	51 [1.80]		
32 [1.260]		1329 [46.88]	93 [3.28]		

- Notes: 1. The above table is for the standard strokes.
 2. There are 2 types of sensor switch lead wire lengths.
 A: 1000mm [39in.], B: 3000mm [118in.]

Calculation example: The mass for bore size of 20mm and stroke of 60mm with 2 sensor switches (ZC135A),
 $393 + (36 \times 6) + (15 \times 2) = 639g$ [22.54oz.]

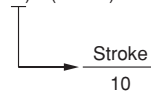

Dimensions mm [in.]

● $\phi 10$

CS-TBDA10 × Stroke

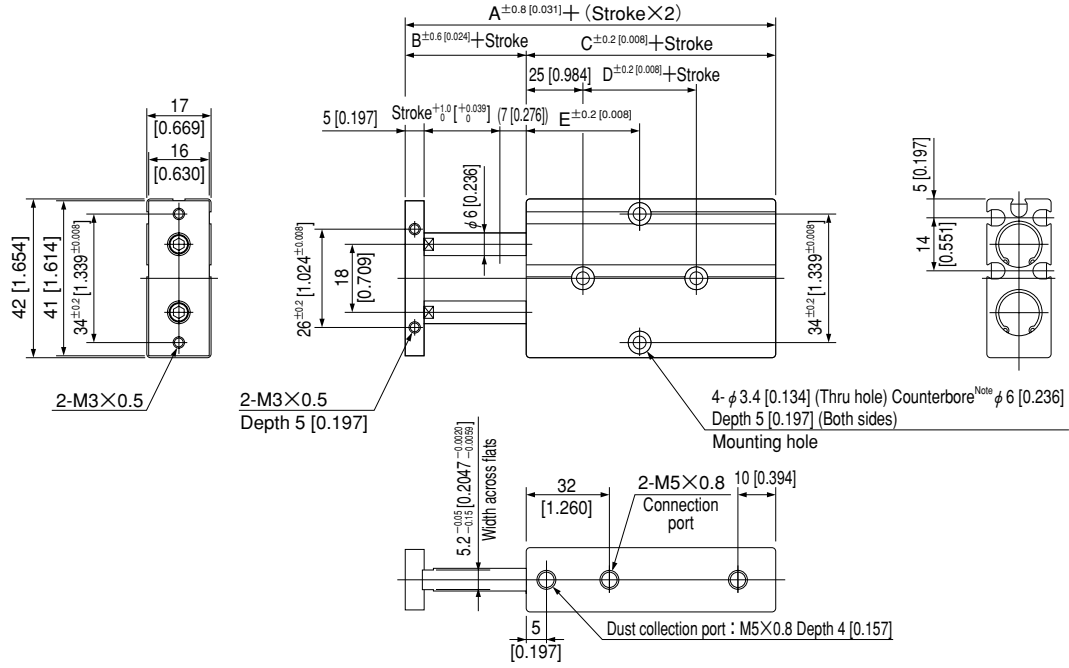

Code Stroke	A	B	C	D	E						
					10	20	30	40	50	60	70
10 [0.394]	68 [2.677]	12 [0.472]	56 [2.205]	10 [0.394]	40 [1.575]	40 [1.575]	45 [1.772]	50 [1.969]	55 [2.165]	60 [2.362]	65 [2.559]

Note: The counterbore depth is measured from the upper surface of the body.

Dimensions mm [in.]

● $\phi 16 \sim \phi 25$ CS-TBDA Bore size \times Stroke

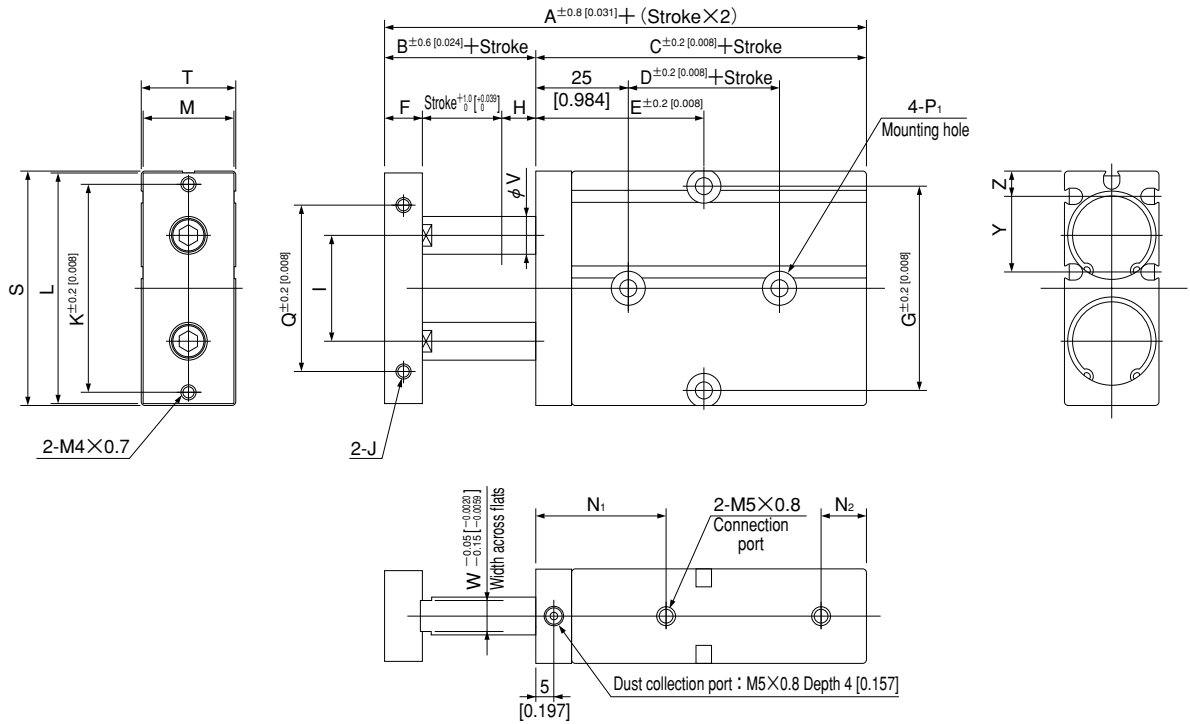

Code Stroke	A	B	C	D	E										F	G	H	I	J	K	L	M	N ₁	N ₂
	10	20	30	40	50	60	70	80	90	100														
16 [0.630]	78 [3.071]	15 [0.591]	63 [2.480]	20 [0.787]	40 [1.575]	45 [1.772]	50 [1.969]	55 [2.165]	60 [2.362]	65 [2.559]	70 [2.756]	75 [2.953]	80 [3.150]	85 [3.346]	8 [0.315]	47 [1.850]	7 [0.276]	24 [0.945]	M4×0.7 Depth 5 [0.197]	47 [1.850]	53 [2.087]	20 [0.787]	32 [1.260]	10 [0.394]
20 [0.787]	88 [3.465]	20 [0.787]	68 [2.677]	20 [0.787]	45 [1.772]	45 [1.772]	50 [1.969]	55 [2.165]	60 [2.362]	65 [2.559]	70 [2.756]	75 [2.953]	80 [3.150]	85 [3.346]	10 [0.394]	55 [2.165]	10 [0.394]	28 [1.102]	M4×0.7 Depth 5 [0.197]	55 [2.165]	61 [2.402]	24 [0.945]	35 [1.378]	12 [0.472]
25 [0.984]	91 [3.583]	19 [0.748]	72 [2.835]	30 [1.181]	50 [1.969]	50 [1.969]	55 [2.165]	60 [2.362]	65 [2.559]	70 [2.756]	75 [2.953]	80 [3.150]	85 [3.346]	90 [3.543]	10 [0.394]	66 [2.598]	9 [0.354]	34 [1.339]	M4×0.8 Depth 6 [0.236]	66 [2.598]	72 [2.835]	29 [1.142]	40 [1.575]	12 [0.472]

Bore	Code	P ₁ Note	Q	S	T	V	W	Y	Z
16 [0.630]		$\phi 4.5 [0.177]$ (Thru hole) Counterbore $\phi 8 [0.315]$ Depth 5.5 [0.217] (Both sides)	34 [1.339]	54 [2.126]	21 [0.827]	8 [0.315]	6.2 [0.244]	18.5 [0.728]	5.7 [0.224]
20 [0.787]		$\phi 4.5 [0.177]$ (Thru hole) Counterbore $\phi 8 [0.315]$ Depth 5.5 [0.217] (Both sides)	44 [1.732]	62 [2.441]	25 [0.984]	10 [0.394]	8.2 [0.323]	20 [0.787]	6.8 [0.268]
25 [0.984]		$\phi 4.5 [0.177]$ (Thru hole) Counterbore $\phi 9 [0.354]$ Depth 6 [0.236] (Both sides)	56 [2.205]	73 [2.874]	30 [1.181]	12 [0.472]	10.2 [0.402]	22.5 [0.886]	8.3 [0.327]

Note: The counterbore depth is measured from the upper surface of the body.

Dimensions mm [in.]

● $\phi 32$

CS-TBDA32 × Stroke

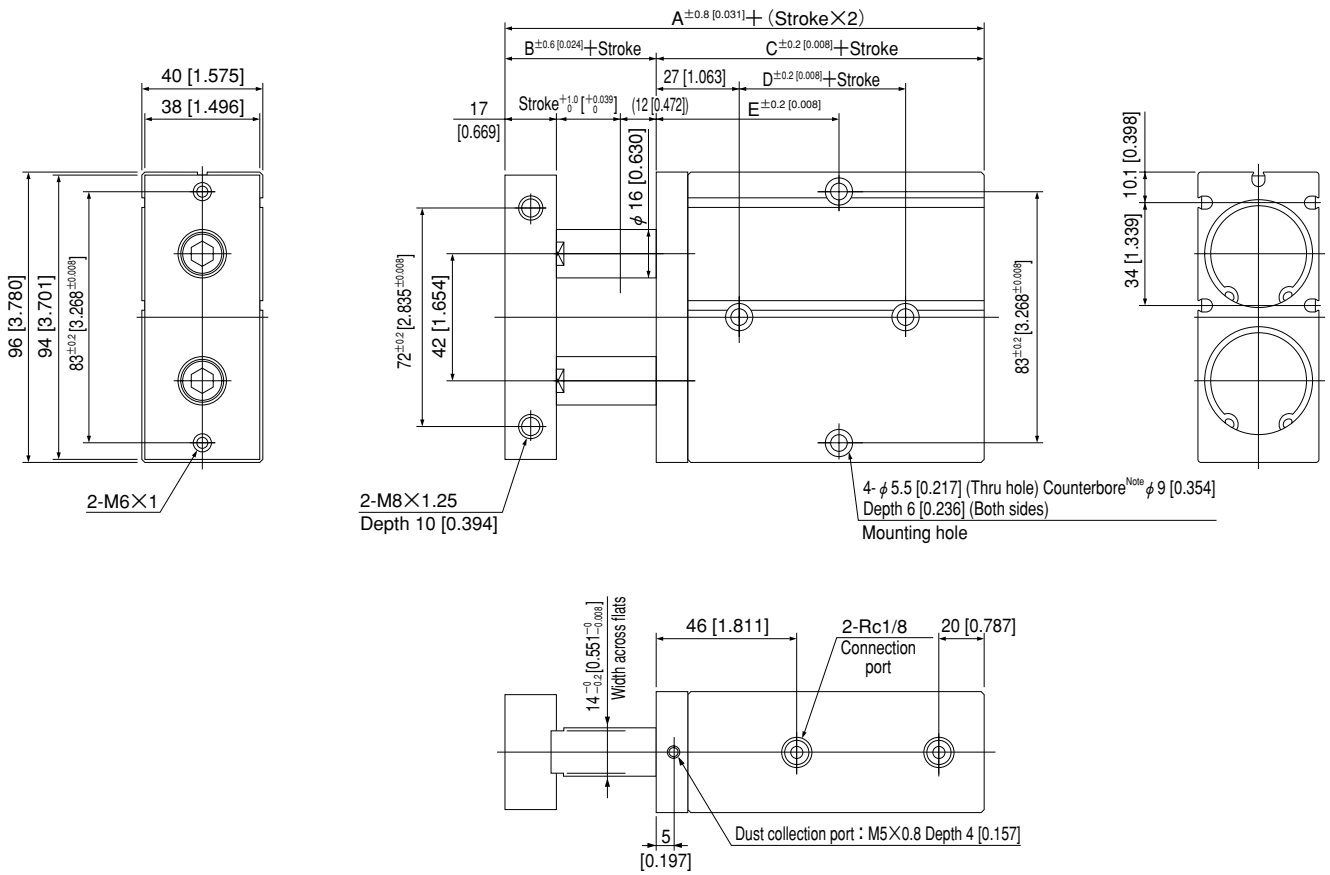

Code Stroke	A	B	C	D	E									
					10	20	30	40	50	60	70	80	90	100
32 [1.260]	118 [4.646]	30 [1.181]	88 [3.465]	35 [1.378]	55 [2.165]	60 [2.362]	65 [2.559]	70 [2.756]	75 [2.953]	80 [3.150]	85 [3.346]	90 [3.543]	95 [3.740]	100 [3.937]

Note: The counterbore depth is measured from the upper surface of the body.

TWIN ROD CYLINDERS B SERIES

Sensor Switches

Order Codes

CS — [] — [] — TBDA

Clean system product

Lead wire length

A : 1000mm [39in.]
B : 3000mm [118in.]

Twin rod cylinder B series

with sensor switch mounting screw
for ϕ 10 [0.394in.] ~ ϕ 32 [1.260in.]

Sensor switch

ZE135 — 2-lead wire, Solid state type with indicator lamp	DC10~28V	Horizontal lead wire	ZE155 — 3-lead wire, Solid state type with indicator lamp	DC4.5~28V	Horizontal lead wire
ZE235 — 2-lead wire, Solid state type with indicator lamp	DC10~28V	Vertical lead wire	ZE255 — 3-lead wire, Solid state type with indicator lamp	DC4.5~28V	Vertical lead wire
ZE101 — 2-lead wire, Reed switch type without indicator lamp	DC5~28V AC85~115V	Horizontal lead wire	ZE102 — 2-lead wire, Reed switch type with indicator lamp	DC10~28V AC85~115V	Horizontal lead wire
ZE201 — 2-lead wire, Reed switch type without indicator lamp	DC5~28V AC85~115V	Vertical lead wire	ZE202 — 2-lead wire, Reed switch type with indicator lamp	DC10~28V AC85~115V	Vertical lead wire

● For details of the sensor switches, see p.111 ~ 121.

Sensor Switch Operating Range, Response Differential, and Maximum Sensing Location

● Operating range: ℓ

The distance the piston travels in one direction, while the switch is in the ON position.

● Response differential: C

The distance between the point where the piston turns the switch ON and the point where the switch is turned OFF as the piston travels in the opposite direction.

● Sensor switch mounting surface

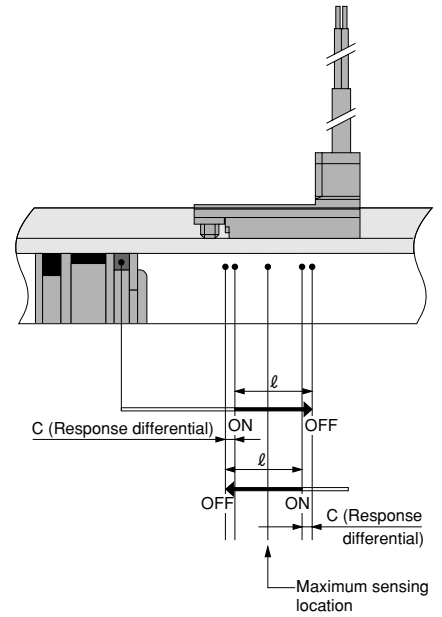
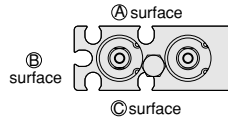

● Solid state type

Item	Mounting surface	Bore size				
		10 [0.394]	16 [0.630]	20 [0.787]	25 [0.984]	32 [1.260]
Operating range : ℓ	A and C surface	2.5~6 [0.098~0.236]			2.5~6.5 [0.098~0.256]	5~12 [0.197~0.472]
	B surface	2.5~4 [0.098~0.157]	2~4.5 [0.079~0.177]		2.5~5.5 [0.098~0.217]	4~9 [0.157~0.354]
Response differential : C	—	1.0 [0.039] or less	1.2 [0.047] or less		1.5 [0.059] or less	2.0 [0.079] or less
Maximum sensing location ^{Note}	—	6 [0.236]				

Remark: The above table shows reference values.

Note: The maximum sensing location is the distance from the end of the switch opposite to the lead wire.

● Reed switch type

Item	Bore size	Bore size				
		10 [0.394]	16 [0.630]	20 [0.787]	25 [0.984]	32 [1.260]
Operating range : ℓ	—	6~8.5 [0.236~0.335]		6~8 [0.236~0.315]	7~9.5 [0.276~0.374]	12~16.5 [0.472~0.650]
Response differential : C	—	1.5 [0.059] or less				2.5 [0.098] or less
Maximum sensing location ^{Note}	—	10 [0.394]				

Remark: The above table shows reference values.

Note: The maximum sensing location is the distance from the end of the switch opposite to the lead wire.

When Mounting Cylinders with Sensor Switches in Close Proximity

When mounting cylinders in close proximity, install the cylinder so that it should exceed the values in the table below.

mm [in.]

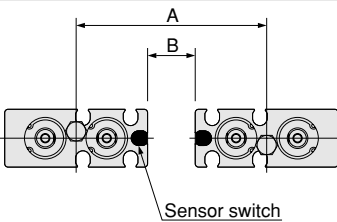
Status of mounting in close proximity	Code	Bore size Type	10 [0.394]	16 [0.630]	20 [0.787]	25 [0.984]	32 [1.260]
				A	Solid state type	53 [2.087]	66 [2.598]
		Reed switch type	48 [1.890]	60 [2.362]	68 [2.677]	81 [3.189]	109 [4.291]
	B	Solid state type	11 [0.433]	12 [0.472]	11 [0.433]	14 [0.551]	23 [0.906]
		Reed switch type	6 [0.236]			8 [0.315]	13 [0.512]

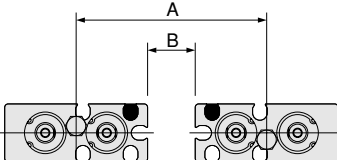
	A	Solid state type	47 [1.850]	59 [2.323]	65 [2.559]	77 [3.031]	107 [4.213]
		Reed switch type	42 [1.654]	54 [2.126]	62 [2.441]	73 [2.874]	96 [3.780]
	B	Solid state type	5 [0.197]		3 [0.118]	4 [0.157]	11 [0.433]
		Reed switch type	0 [0]				

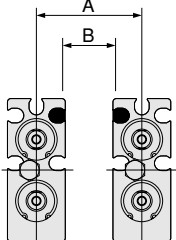
	A	Solid state type	28 [1.102]	33 [1.299]	36 [1.417]	44 [1.732]	65 [2.559]
		Reed switch type	22 [0.866]	27 [1.063]	30 [1.181]	37 [1.457]	53 [2.087]
	B	Solid state type	11 [0.433]	12 [0.472]	11 [0.433]	14 [0.551]	25 [0.984]
		Reed switch type	5 [0.197]	6 [0.236]	5 [0.197]	7 [0.276]	13 [0.512]

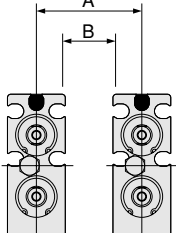
	A	Solid state type	21 [0.827]	24 [0.945]	25 [0.984]	30 [1.181]	44 [1.732]
		Reed switch type	17 [0.669]	21 [0.827]	25 [0.984]	30 [1.181]	40 [1.575]
	B	Solid state type	4 [0.157]	3 [0.118]	0 [0]		4 [0.157]
		Reed switch type	0 [0]				

Remark: For mounting in configurations other than the above, consult us.

Mounting Location of End of Stroke Detection Sensor Switch

When the sensor switch is mounted in the locations shown below (figures in the tables are reference values), the magnet comes to the maximum sensing location of the sensor switch at the end of the stroke.

■ When the lead wire is pulled from the head side.

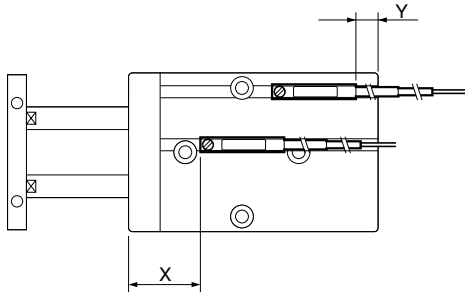

■ When the lead wire of the head side detection sensor switch only is pulled from the rod side.

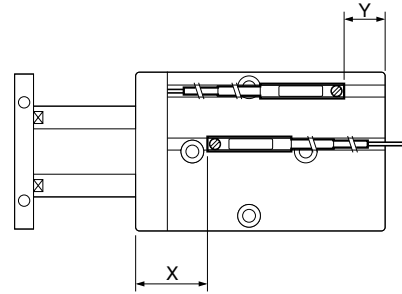

● Solid state type

mm [in.]

Code \ Bore	10 [0.394]	16 [0.630]	20 [0.787]	25 [0.984]	32 [1.260]
X	37.5 [1.476]	43.5 [1.713]	47.5 [1.870]	52.5 [2.067]	62 [2.441]
Y	-3.5 [-0.138]	-2.5 [-0.098]	-1.5 [-0.059]	-2.5 [-0.098]	4 [0.157]

● Reed switch type

mm [in.]

Code \ Bore	10 [0.394]	16 [0.630]	20 [0.787]	25 [0.984]	32 [1.260]
X	33.5 [1.319]	39.5 [1.555]	43.5 [1.713]	48.5 [1.909]	58 [2.283]
Y	0.5 [0.020]	1.5 [0.059]	2.5 [0.098]	1.5 [0.059]	8 [0.315]

● Solid state type

mm [in.]

Code \ Bore	10 [0.394]	16 [0.630]	20 [0.787]	25 [0.984]	32 [1.260]
X	37.5 [1.476]	43.5 [1.713]	47.5 [1.870]	52.5 [2.067]	62 [2.441]
Y	6.5 [0.256]	7.5 [0.295]	8.5 [0.335]	7.5 [0.295]	14 [0.551]

● Reed switch type

mm [in.]

Code \ Bore	10 [0.394]	16 [0.630]	20 [0.787]	25 [0.984]	32 [1.260]
X	33.5 [1.319]	39.5 [1.555]	43.5 [1.713]	48.5 [1.909]	58 [2.283]
Y	2.5 [0.098]	3.5 [0.138]	4.5 [0.177]	3.5 [0.138]	10 [0.394]