

Inner construction

- MFZ30
- MFZ40
- MFZ50

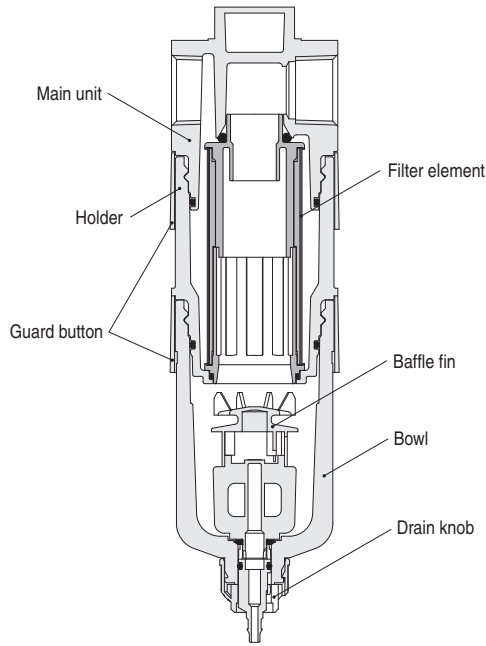

Flow rate characteristics

MFZ30-F11-01

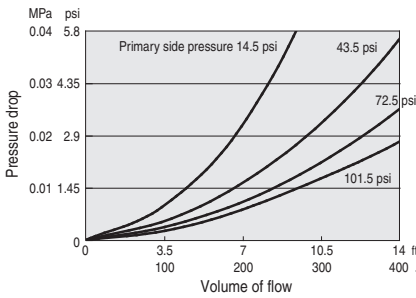

MFZ40-F11-01

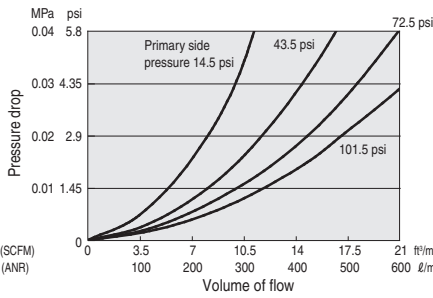

MFZ50-F11-02

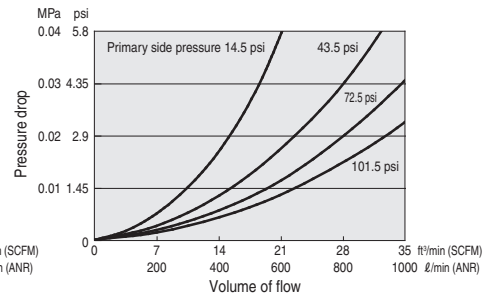

MFZ30-F11-02

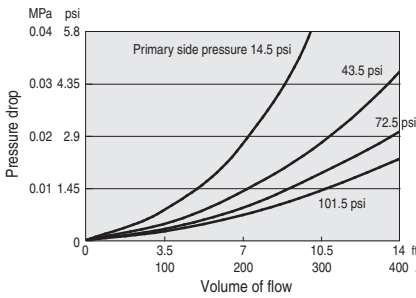

MFZ40-F11-02

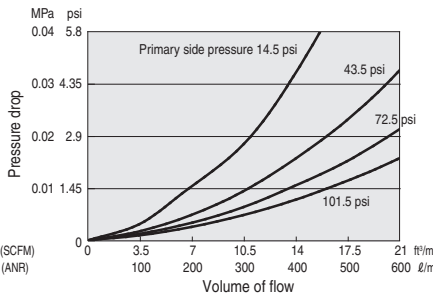

MFZ50-F11-03

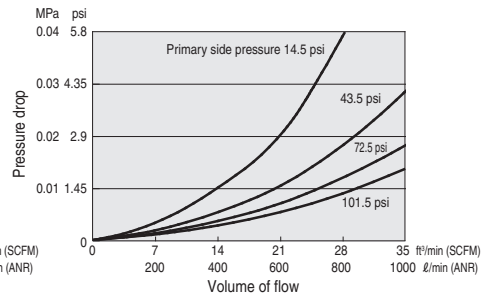

MFZ40-F11-03

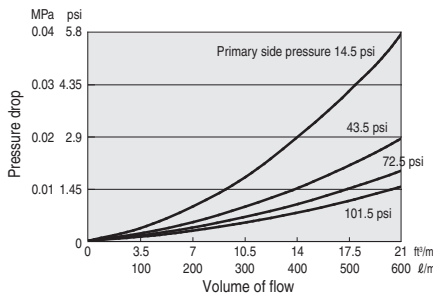

MFZ50-F11-04

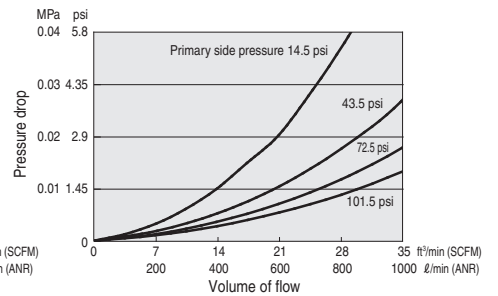

1 MPa = 145 psi
 1 l/min = 0.0353 ft³/min