

Adjustment Type Linear Orifice® Shock Absorber KSHP Series

Introducing the **adjustable** linear orifice!
Long **3 million cycle** operating life! (M42 Exc.)
Uses NSF certified **H1 oil** (non silicon)



KSHJ

KSHY

KSHP

KSHC

Additional Parts

Handling Instructions and Precautions



General precautions

Cover the unit when mounting it in locations where it might be subject to excessive dust, dripping water, dripping oil, etc. Dents, scratches, water, oil, or dust on the piston rod results in damage and decreases service life.



Mounting

1. Keep the angle of eccentricity, resulting from the load direction and the axis of the shock absorber, under the specified values on page 5. If an eccentric load exceeding the specifications is applied, it could result in breakage or impaired returns. If there is concern that an eccentric load exceeding the specified values will be applied, install a guide, or similar mechanism.
2. You cannot mount two or more adjustable type shock absorbers in parallel to boost the absorption capacity (it is difficult to adjust the capacity evenly).
3. If using a shock absorber with a plastic or rubber cap, always mount a stopper nut (-S) or an external stopper to ensure that the cap is not subjected to loads at the stroke end. Install the stopper nut in a position such that $A \leq$ the stroke of the shock absorber. Furthermore, you can use a shock absorber that has a plastic cap without a stopper nut (-S) or external stopper, but, over the long-term, the stop location will change due to cap deformation and wear.

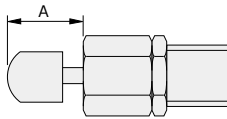

4. Rubber caps are consumable parts. The service life will vary depending on conditions of the application, replace these parts according to their condition.
5. If using a shock absorber with a rubber cap for lateral impacts, such as eccentric or swing impacts, note that the rubber cap may come off or be damaged.
6. When mounting the shock absorber, always use the following maximum tightening torque guidelines. Tightening using excessive force may result in damage.

Model	Maximum tightening torque	
	N · m	in · lbf
KSHP6 × 4 (C)(-F11)	0.85	7.523
KSHP8 × 6 (C)(-11)(-F11)	2.5	22.128
KSHP10 × 8 (C)(-F11)	6.5	57.532
KSHP11 × 8 (C)-F11	—	57.5
KSHP12 × 10 (C,R)(-F11)	8.0	70.808
KSHP14 × 12 (C,R)(-F11)	12.0	106.2
KSHP16 × 15 (C,R)	20.0	—
KSHP18 × 20 (C,R)(-F11)	25.0	221.3
KSHP20 × 22 (C,R)	30.0	—
KSHP25 × 25 (C,R)(-F11)	42.0	371.7
KSHP30 × 30 (C,R)(-F11)	60.0	531.1
KSHP36 × 50 (C,R)(-F11)	72.0	637.3
KSHP42 × 50 (C,R)(-F11)	85.0	752.3

7. Ensure that the hardness of the surface directly impacting the piston rod of the shock absorber is over HRc40 hardness (excluding models with rubber or plastic caps).
8. Be aware that performance and characteristics change depending on the operating temperature.



Adjusting the shock absorbing capacity

1. For the KSHP10 to KSHP42 models, align the red mark on the adjusting knob to the 6 on the scale. For the KSHP6 and KSHP8 models, align the 6 on the scale to the key slot on the body.
2. For large impacts on collision or if a long time is required for a full stroke, reduce the value on the scale gradually.
3. Always tighten the lock screw to fix the knob in place after completing adjustment. (excluding KSHP6 and KSHP8)

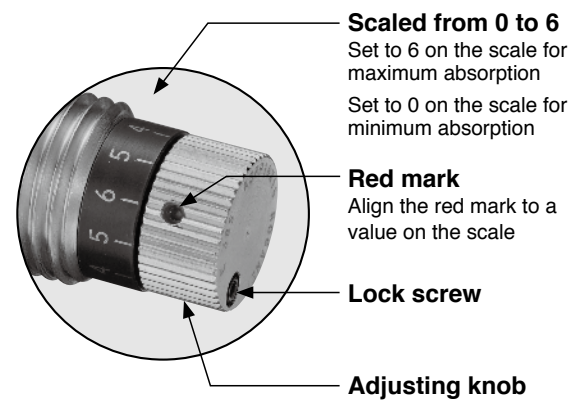

For KSHP6 and KSHP8

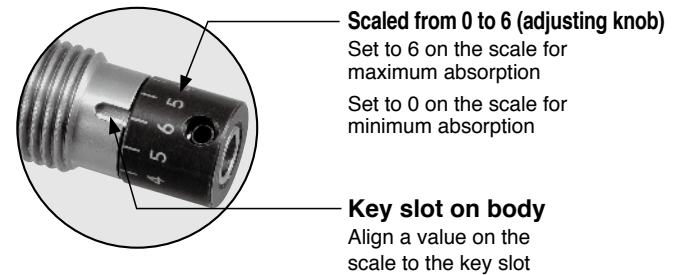

● Lock screw dimensions mm [in]

For KSHP 10 to 14

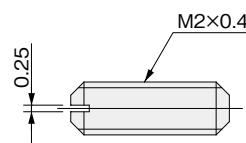

For KSHP 16 to 42

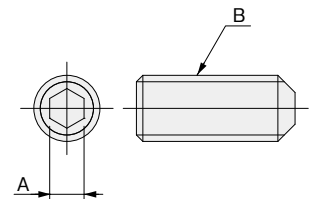

Model	Symbol	A	B
KSHP16 to 18		1.3	M2.5×0.45
KSHP20 to 42		1.5	M3×0.5

■ How to select shock absorbers

1. Confirm the thrust

Confirm the thrust that is used, and then check the prospective shock absorbers from the table of recommended cylinder bore sizes on page 49. If a shock absorber that is smaller than the recommended shock absorber is used, the shock absorber being used may be damaged in fewer operation cycles than is guaranteed.

2. Confirm the kinetic energy

Confirm I and II below, and then check page 50 for the selection graphs for prospective shock absorbers from [1. Confirm the thrust]. (*)

I Impact object mass: m [kg]

II Impact speed: v [m/s]

Because “v” is the impact speed, not the average speed, when using a cylinder,

$$v = m [\text{cylinder stroke}] \div s [\text{operating time}] \times 2$$

Select a model in which I and II fit within the range enclosed by the capacity curves.

If multiple models are applicable, use the model that is closest to both the capacity curves and the operating conditions. The further the model you select is from the capacity curves and the operating conditions, the slower it will tend to be.

3. Confirm other specifications

Confirm that such specifications as the maximum operating frequency, maximum absorption capacity per unit of time, angle of eccentricity, and operating temperature range are within the range for the shock absorber that you selected.

* The value for the kinetic energy, E, can be found by doing the following calculation. However, the shock absorber’s capacity for absorption changes depending on the impact speed. When the shock absorber is doing low-speed operations, it has less drag than when it is doing high-speed operations.

The maximum absorption capacity that is noted in the specifications is reached only at the maximum impact speed.

Therefore, do not choose a shock absorber by comparing E to the maximum absorption capacity; confirm the capacity using the selection graph.

$$E = \frac{1}{2} mv^2$$

E: Kinetic energy (J)

m: Impact object mass [kg]

v: Impact speed (m/s)

Range in the selection graph

Vertical axis range :

$$\text{Maximum impact speed} \geq v \text{ Impact speed (operating condition)}$$

Horizontal axis range :

$$\text{Shock absorber's maximum absorption capacity at the impact speed (v = m/s)} \geq \frac{E}{\text{Kinetic energy (operating condition)}}$$

Calculating the thrust energy is not necessary because the size of the shock absorber is limited by the thrust in step 1.

■ Koganei’s selectable content

You can also select equipment from Koganei’s homepage.

Visit <http://www.koganei.co.jp>.

The results of selections using the method above may differ from the results of selections for the selectable content on our homepage. If this happens, please contact us.

■ Example of selecting a shock absorber

[Operating conditions]

① Bore size of the cylinder being used: φ16

② Cylinder stroke: 100 mm = 0.1 m

③ Pressure applied to the cylinder: 0.6 MPa

④ Cylinder’s operating time: 0.4 s

⑤ Impact object mass: 10 kg

1. Confirm the thrust

Either calculate or find the thrust in the cylinder thrust table on page 49.

The cylinder thrust based on ① and ③ is about 121 N.

Cylinder thrust	100.5N	<	120.6N	<	126N
Cylinder bore size	φ 16		φ 16		φ 20
Applied pressure	0.5MPa		0.6MPa		0.4MPa

As mentioned above, although the cylinder being used is φ16, the pressure applied to the cylinder exceeds 0.5 MPa, so consider the φ20 cylinder (lower than 0.4 MPa) and check the table of recommended cylinder bore sizes on page 49.

The following are prospective models.

- KSHP10×8 • KSHP12×10 • KSHP14×12
- KSHP16×15 • KSHP18×20 • KSHP20×22

2. Confirm the kinetic energy

I The impact object mass m = 10 kg from ⑤

II Find the impact speed, v, from ② and ④.

$$v = \frac{②}{④} \times 2 = \frac{0.1 \text{ m}}{0.4 \text{ s}} \times 2 = 0.5 \text{ m/s}$$

According to the selection graphs on page 48, the shock absorber with the optimum absorption capacity for operating conditions is KSHP12×10.

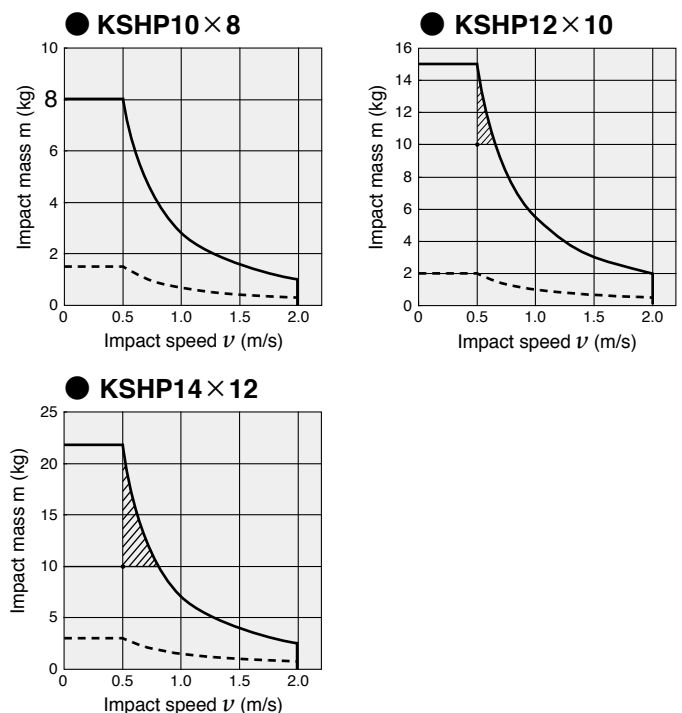

- KSHP10×8 has an insufficient absorption capacity.
- The absorption capacities for all of the other shock absorbers are higher than that of KSHP12×10, so they do not fall within the operating conditions and capacity curves.

3. Confirm other specifications

Verify that other operating conditions, such as the maximum operating frequency, maximum absorption capacity per unit of time, angle of eccentricity, and operating temperature range, are within the specified ranges for KSHP12×10.

Selection Guidelines

Recommended cylinder bore size

Model	Cylinder bore														
	φ4	φ6	φ8	φ10	φ12	φ16	φ20	φ25	φ32	φ40	φ50	φ63	φ80	φ100	φ125
KSHP6 × 4 (-F11)	◇	◇	◎	◎	○										
KSHP8 × 6 (-11)(-F11)		◇	◇	◎	◎	○									
KSHP10 × 8 (-F11)			◇	◇	◎	◎	○								
KSHP11 × 8-F11			◇	◇	◎	◎	○								
KSHP12 × 10 (-F11)				◇	◇	◎	◎	○							
KSHP14 × 12 (-F11)					◇	◇	◎	◎	○						
KSHP16 × 15						◇	◇	◎	◎	○					
KSHP18 × 20 (-F11)							◇	◇	◎	◎					
KSHP20 × 22							◇	◇	◎	◎	○				
KSHP25 × 25 (-F11)								◇	◇	◎	◎	○			
KSHP30 × 30 (-F11)									◇	◇	◎	◎	○		
KSHP36 × 50 (-F11)										◇	◇	◎	◎	○	
KSHP42 × 50 (-F11)											◇	◇	◎	◎	○

◇ : 0.3 MPa or higher ◎ : 0.5 MPa or lower ○ : 0.4 MPa or lower

Note 1: If a shock absorber that is smaller than the recommended shock absorber is used, the shock absorber being used may be damaged in fewer operation cycles than the value that is guaranteed.

Note 2: KSHP11 × 8 has only inch specifications.

Cylinder thrust

N [lbf.]

Bore size mm [in.]	Pressure area mm ² [in. ²]	Air pressure MPa [psi.]									
		0.1 [15]	0.2 [29]	0.3 [44]	0.4 [58]	0.5 [73]	0.6 [87]	0.7 [102]	0.8 [116]	0.9 [131]	
φ4	12.6 [0.020]	1.3 [0.292]	2.5 [0.562]	3.8 [0.854]	5 [1.124]	6.3 [1.416]	7.5 [1.686]	8.8 [1.978]	10.1 [2.270]	11.3 [2.540]	
φ6	28.3 [0.044]	2.8 [0.629]	5.7 [1.281]	8.5 [1.911]	11.3 [2.540]	14.1 [3.170]	17.0 [3.822]	19.8 [4.451]	22.6 [5.080]	25.4 [5.710]	
φ8	50.3 [0.078]	5 [1.124]	10.1 [2.270]	15.1 [3.394]	20.1 [4.518]	25.1 [5.642]	30.2 [6.789]	35.2 [7.913]	40.2 [9.037]	45.2 [10.161]	
φ10	78.5 [0.122]	7.9 [1.776]	15.7 [3.529]	23.6 [5.305]	31.4 [7.059]	39.3 [8.835]	47.1 [10.588]	55 [12.364]	62.8 [14.117]	70.7 [15.893]	
φ12	113 [0.175]	11.3 [2.540]	22.6 [5.080]	33.9 [7.621]	45.2 [10.161]	56.5 [12.701]	67.9 [15.264]	79.2 [17.804]	90.5 [20.344]	101.8 [22.885]	
φ16	201 [0.312]	20.1 [4.518]	40.2 [9.037]	60.3 [13.555]	80.4 [18.074]	100.5 [22.592]	121 [27.201]	141 [31.697]	161 [36.193]	181 [40.689]	
φ20	314 [0.487]	31.4 [7.059]	62.8 [14.117]	94.2 [21.176]	126 [28.325]	157 [35.294]	188 [42.262]	220 [49.456]	251 [56.425]	283 [63.618]	
φ25	491 [0.761]	49.1 [11.038]	98.2 [22.075]	147 [33.046]	196 [44.061]	245 [55.076]	295 [66.316]	344 [77.331]	393 [88.346]	442 [99.362]	
φ32	804 [1.246]	80.4 [18.074]	161 [36.193]	241 [54.177]	322 [72.386]	402 [90.370]	483 [108.6]	563 [126.6]	643 [144.5]	724 [162.8]	
φ40	1257 [1.948]	126 [28.325]	251 [56.425]	377 [84.750]	503 [113.1]	628 [141.2]	754 [169.5]	880 [197.8]	1005 [225.9]	1131 [254.2]	
φ50	1963 [3.043]	196 [44.061]	393 [88.346]	589 [132.4]	785 [176.5]	982 [220.8]	1178 [264.8]	1374 [308.9]	1571 [353.2]	1767 [397.2]	
φ63	3117 [4.831]	312 [70.138]	623 [140.1]	935 [210.2]	1247 [280.3]	1559 [350.5]	1870 [420.4]	2182 [490.5]	2494 [560.7]	2806 [630.8]	
φ80	5027 [7.792]	503 [113.1]	1005 [225.9]	1508 [339.0]	2011 [452.1]	2513 [564.9]	3016 [678.0]	3519 [791.1]	4021 [903.9]	4524 [1017]	
φ100	7854 [12.174]	785 [176.5]	1571 [353.2]	2356 [529.6]	3142 [706.3]	3927 [882.8]	4712 [1059]	5498 [1236]	6283 [1412]	7069 [1589]	
φ125	12272 [19.022]	1227 [275.8]	2454 [551.7]	3682 [827.7]	4909 [1104]	6136 [1379]	7363 [1655]	8590 [1931]	9817 [2207]	11045 [2483]	

Selection Guidelines

Cautions for using the selection graphs

1. The selection graphs are calculated with a cylinder operating air pressure of 0.5 MPa.
2. The values in the selection graphs are for room temperature (20 to 25°). Be aware that performance and characteristics change depending on the operating temperature.
3. Select a shock absorber that is as close to, yet within, the capacity line(s).
4. You can select them on the Koganei home page. Go to <http://www.koganei.co.jp>
The results of selections using our catalog may differ from the results of selections on our homepage.

Selection graph

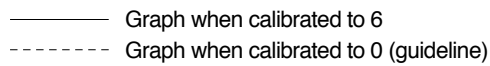

● KSHP6 × 4 (-F11)

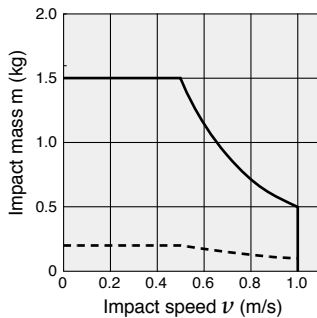

● KSHP8 × 6 (-F11)

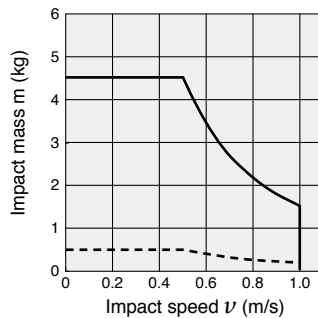

● KSHP10 × 8 (-F11)

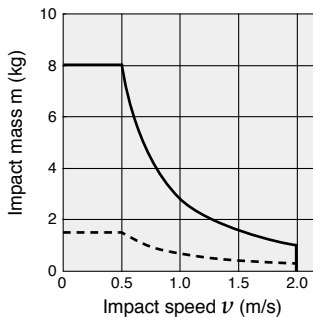

● KSHP11 × 8-F11

● KSHP12 × 10 (-F11)

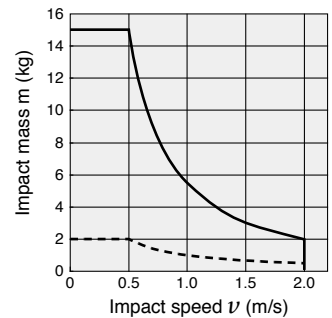

● KSHP14 × 12 (-F11)

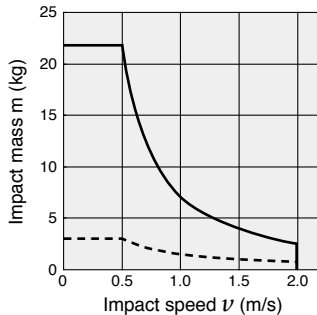

● KSHP16 × 15

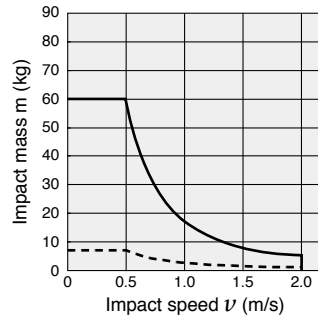

● KSHP18 × 20 (-F11)

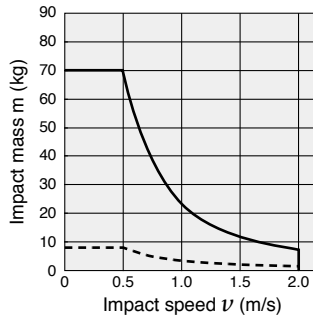

● KSHP20 × 22

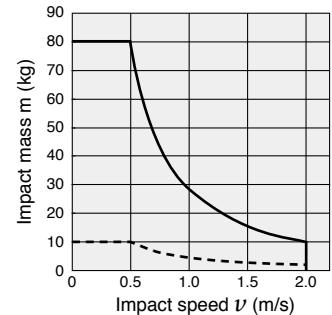

● KSHP25 × 25 (-F11)

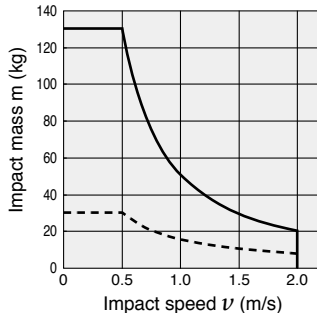

● KSHP30 × 30 (-F11)

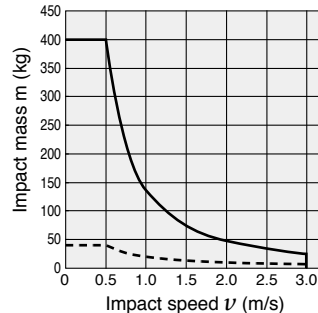

● KSHP36 × 50 (-F11)

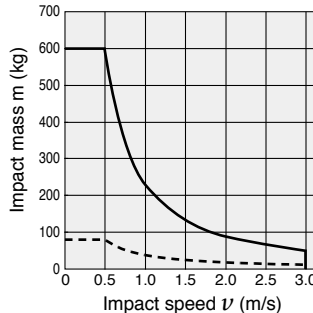

● KSHP42 × 50-F11

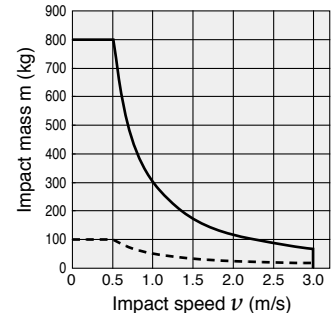

Linear orifice shock absorber

KSHP Series

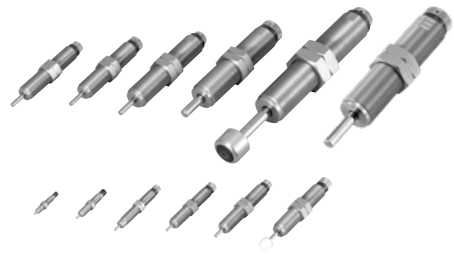

Specifications

Model (in inches)		KSHP6 × 4 (KSHP6 × 4-F11)	KSHP8 × 6, KSHP8 × 6-11 (KSHP8 × 6-F11)
Item			
Maximum absorption capacity	J(in.lbs)	0.25 (2.213)	0.75 (6.638)
Absorption stroke	mm(in.)	4 (0.157)	6 (0.236)
Impact speed range	m/s(ft/s)	0.1 to 1 (0.33 to 3.28)	
Maximum operating cycle	cycle/min	50	
Maximum absorption capacity per unit of time	J/min (in.lbs/min)	7.5 (66.4)	22.5 (199.3)
Spring return force ^{Note1}	N	2.6	2.9
Deflection angle		1° or less	
Operating temperature range ^{Note2}	°C(°F)	0 to 60 (32 to 140)	

Model (in inches)		KSHP10 × 8 (KSHP10 × 8-F11, KSHP11 × 8-F11)	KSHP12 × 10 (KSHP12 × 10-F11)	KSHP14 × 12 (KSHP14 × 12-F11)
Item				
Maximum absorption capacity	J(in.lbs)	2 (17.701)	4 (35.403)	5 (44.254)
Absorption stroke	mm(in.)	8 (0.315)	10 (0.394)	12 (0.472)
Impact speed range	m/s(ft/s)	0.1 to 2 (0.33 to 6.56)		
Maximum operating cycle	cycle/min	50		
Maximum absorption capacity per unit of time	J/min (in.lbs/min)	60 (531.4)	120 (1062.7)	150 (1328.4)
Spring return force ^{Note1}	N	6.5	9.6	9.0
Deflection angle		1° or less		
Operating temperature range ^{Note2}	°C(°F)	0 to 60 (32 to 140)		

Model (in inches)		KSHP16 × 15	KSHP18 × 20 (KSHP18 × 20-F11)	KSHP20 × 22
Item				
Maximum absorption capacity	J(in.lbs)	10	15 (132.8)	20
Absorption stroke	mm(in.)	15	20 (0.787)	22
Impact speed range	m/s(ft/s)	0.1 to 2 (0.33 to 6.56)		
Maximum operating cycle	cycle/min	40		30
Maximum absorption capacity per unit of time	J/min (in.lbs/min)	240	360 (3188.2)	360
Spring return force ^{Note1}	N	20.5	23.0	18.4
Deflection angle		3° or less		
Operating temperature range ^{Note2}	°C(°F)	0 to 60 (32 to 140)		

Model (in inches)		KSHP25 × 25 (KSHP25 × 25-F11)	KSHP30 × 30 (KSHP30 × 30-F11)	KSHP36 × 50 (KSHP36 × 50-F11)
Item				
Maximum absorption capacity	J(in.lbs)	40 (354.0)	110 (973.6)	200 (1770)
Absorption stroke	mm(in.)	25 (0.984)	30 (1.181)	50 (1.969)
Impact speed range	m/s(ft/s)	0.1 to 2 (0.33 to 6.56)	0.1 to 3 (0.33 to 9.84)	
Maximum operating cycle	cycle/min	30	20	15
Maximum absorption capacity per unit of time	J/min (in.lbs/min)	720 (6376.3)	1320 (11690)	1800 (15940.8)
Spring return force ^{Note1}	N	32.3	42.3	65.8
Deflection angle		3° or less		
Operating temperature range ^{Note2}	°C(°F)	0 to 60 (32 to 140)		

Model (in inches)		KSHP42 × 50 (KSHP42 × 50-F11)
Item		
Maximum absorption capacity	J(in.lbs)	300 (2655)
Absorption stroke	mm(in.)	50 (1.969)
Impact speed range	m/s(ft/s)	0.1 to 3 (0.33 to 9.84)
Maximum operating cycle	cycle/min	10
Maximum absorption capacity per unit of time	J/min (in.lbs/min)	2000 (17712.0)
Spring return force ^{Note1}	N	64.2
Deflection angle		3° or less
Operating temperature range ^{Note2}	°C(°F)	0 to 60 (32 to 140)

Note1: The spring return force is the force of the piston rod when it returns from a full stroke. It is not stable, so cannot be used as other than rod return.

Note2: The shock absorber's shock absorbing capacity fluctuates based on speed and ambient temperature.

Use the product within the ranges of the selection graphs (impact mass, impact speed diagram) on page 50.

Note3: KSHP11 has only inch specifications.

* The maximum tightening torque of KSHP11 is different from that of KSHP10. See page 47 for details on the maximum tightening torque.

Note4: KSHP16 × 15 and KSHP20 × 22 do not have inch specifications.

Mass (Specifications in mm)

Model	Main unit ^{Note}	Additional mass		Additional parts' mass		
		With plastic cap	With rubber cap	Mounting nut (1 ea.)	Stopper nut	Side mounting bracket
KSHP6 × 4	5.1	0.2	—	0.4	2	8
KSHP8 × 6 (-11)	11.3(11.5)	0.5	—	0.6(0.9)	4	12
KSHP10 × 8	26.5	0.7	—	1.2	7	15
KSHP12 × 10	43.5	1.1	1.2	1.9	8	22
KSHP14 × 12	66.5	1.1	1.8	4.0	15	41
KSHP16 × 15	98.5	1.6	3.4	6.6	28	65
KSHP18 × 20	144	4.1	5.3	8.8	37	100
KSHP20 × 22	186	5.4	6.9	12.2	55	110
KSHP25 × 25	360	5.3	5.7	23.0	95	360
KSHP3 × 30	569	50	49	32.5	140	455
KSHP36 × 50	1130	110	109	95.5	330	2650
KSHP42 × 50	1515	110	109	93.0	320	2400

Calculation example: The mass of KSHP10 × 8C-S-2 (with cap, stopper, and side mount) is
 $26.5 + 0.7 + 7 + 15 = 49.2g$

Note: The weight of the main unit includes the weight of 2 mounting nuts.

Order Codes (specifications in mm)

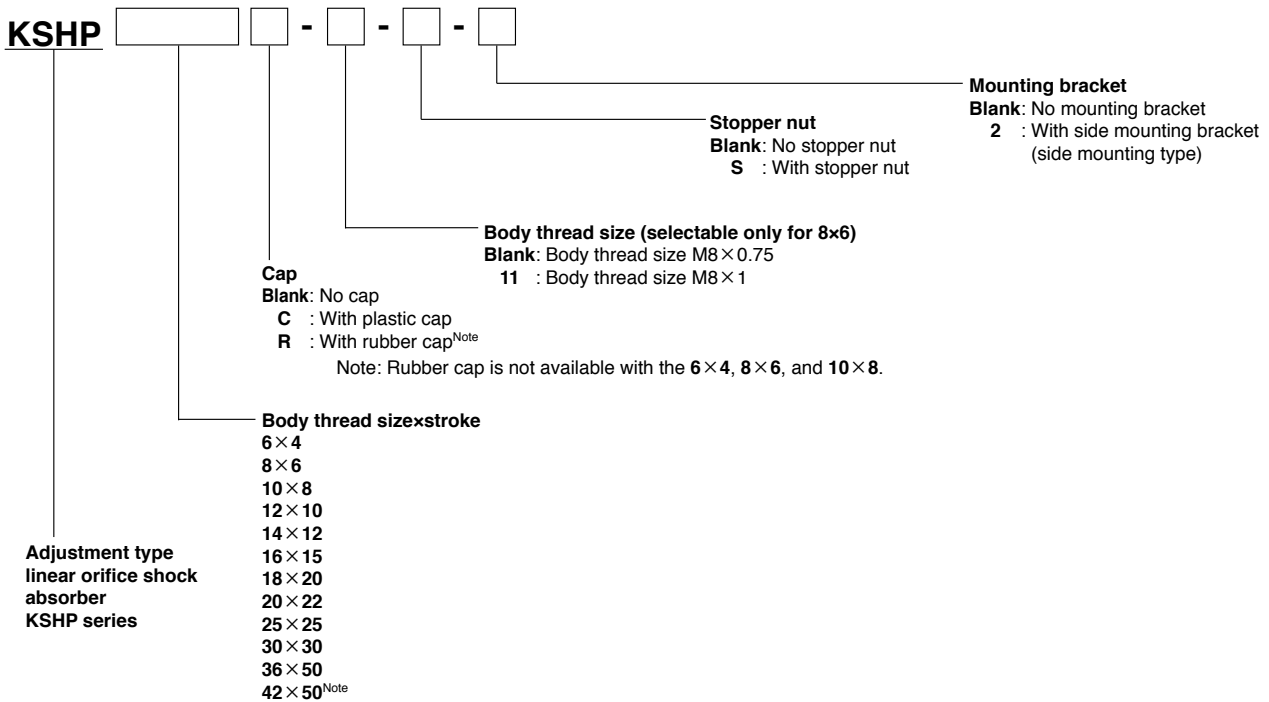

Note: KSHP42 × 50 is a built-to-order product. Contact us about turnaround times, prices, or other information.

Additional Parts (no specifications in inches)

•Rubber cap

R - KSH - M []



Thread size
 12: For KSHP12
 14: For KSHP14
 16: For KSHP16
 18: For KSHP18
 20: For KSHP20
 25: For KSHP25
 30: For KSHP30
 36: For KSHP36
 42: For KSHP42

•Mounting nut (M4 to M20: 1 pack has 10 units) (M25 to M42: 1 pack has 2 units)

N - KSH - M []



Thread size
 6: For KSHP6
 8: For KSHP8
 8-11: For KSHP8-11
 10: For KSHP10
 12: For KSHP12
 14: For KSHP14
 16: For KSHP16
 18: For KSHP18
 20: For KSHP20
 25: For KSHP25
 30: For KSHP30
 36: For KSHP36
 42: For KSHP42

•Stopper nut

S - KSH - M []



Thread size
 6: For KSHP6
 8: For KSHP8
 8-11: For KSHP8-11
 10: For KSHP10
 12: For KSHP12
 14: For KSHP14
 16: For KSHP16
 18: For KSHP18
 20: For KSHP20
 25: For KSHP25
 30: For KSHP30
 36: For KSHP36
 42: For KSHP42

•Side mounting bracket

2 - KSH - M []



Thread size
 6: For KSHP6
 8: For KSHP8
 8-11: For KSHP8-11
 10: For KSHP10
 12: For KSHP12
 14: For KSHP14
 16: For KSHP16
 18: For KSHP18
 20: For KSHP20
 25: For KSHP25
 30: For KSHP30
 36: For KSHP36
 42: For KSHP42

* For the dimension diagrams of the additional parts, see pages 12 to 16.
 * The stopper nut and side mount are made from mild steel (nickel plated).

Inner Construction and Major Parts and Materials

●M6,M8 size (11/4-32 UNEF, 5/16-32 UNEF) * The inch sizes are inside the ().

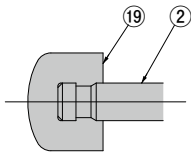
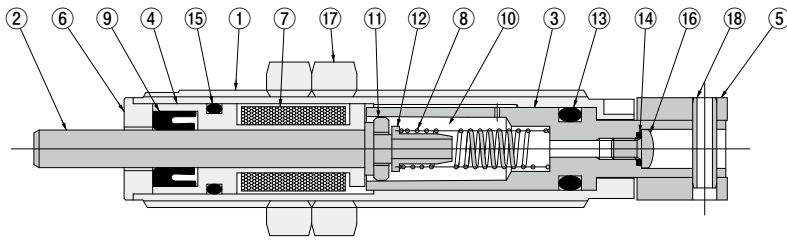

With plastic cap (C)

No	Name	Materials
①	Body	Stainless steel
②	Piston rod	Stainless steel
③	Inner tube	Stainless steel
④	Sleeve	Copper alloy
⑤	Adjusting knob	Copper alloy (black electroplated)
⑥	Plug	Stainless steel
⑦	Accumulator	Synthetic rubber
⑧	Spring	Spring steel
⑨	Rod seal	Synthetic rubber
⑩	Oil	Special oil (H1 compliant)
⑪	Piston ring	Copper alloy
⑫	Collar	Copper alloy
⑬	O-ring	Synthetic rubber
⑭	O-ring	Synthetic rubber
⑮	O-ring ^{Note}	Synthetic rubber
⑯	Screw	Mild steel (nickel plated)
⑰	Mounting nut	Mild steel (nickel plated)
⑱	Spring pin	Steel (oxide film)
⑲	Cap	Plastic (POM)

Note: Not available for KSHP6x4.

●M10 to M42 size (3/8-32 UNEF to 1 3/4-12 UN) * The inch sizes are inside the ().

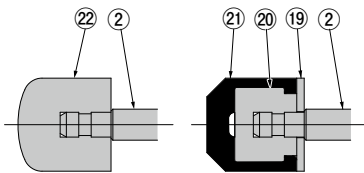
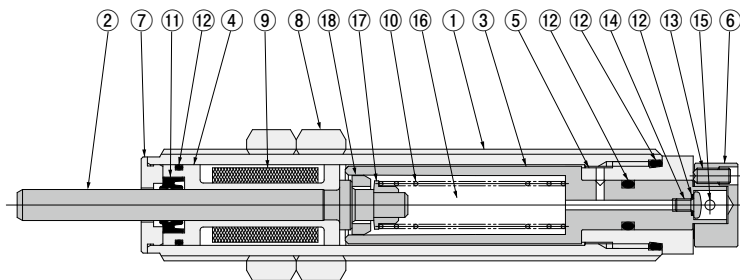

With plastic cap (C) With rubber cap (R)

For KSHP 30 x 30 and KSHP 42 x 50

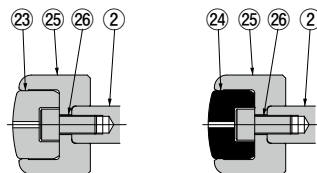

With plastic cap (C) With rubber cap (R)

No.	Name	Materials
①	Body	Free-cutting steel (nickel plated)
②	Piston rod ^{Note1}	Steel (nickel plated)
③	Inner tube	Stainless steel
④	Sleeve	Copper alloy
⑤	Housing	Mild steel (black electroplated)
⑥	Adjusting knob	Copper alloy (nickel plated)
⑦	Plug	Stainless steel
⑧	Mounting nut	Mild steel (nickel plated)
⑨	Accumulator	Synthetic rubber
⑩	Spring	Spring steel
⑪	Rod seal	Synthetic rubber
⑫	O-ring	Synthetic rubber
⑬	Lock screw ^{Note2}	Steel (oxide film)
⑭	Screw ^{Note3}	Mild steel (zinc plated)
⑮	Spring pin	Steel (oxide film)
⑯	Oil	Special oil (H1 compliant)
⑰	Collar ^{Note4}	Stainless steel
⑱	Piston ring	Stainless steel
⑲	Washers ^{Note5}	Stainless steel
⑳	Cap	Plastic (POM)
㉑	Rubber cap	Urethane rubber
㉒	Cap	Plastic (POM)
㉓	Cap	Plastic (POM)
㉔	Rubber cap	Urethane rubber
㉕	Metal cap	Stainless steel
㉖	Hexagon socket head screw	Stainless steel

Note 1: KSHP 10 to 12 are stainless steel
 2: KSHP 10 to 14 are slotted lock screws.
 3: KSHP 30 to 42 are stainless steel with button head screw
 4: KSHP 10 are copper alloy and KSHP 12 to 14 are sintered metal
 5: KSHP 18 to 20 only

Dimensions (mm)

● No rod end cap: **KSHP**□ × □

● With rod end cap

With plastic cap: **KSHP**□ × □ **C**

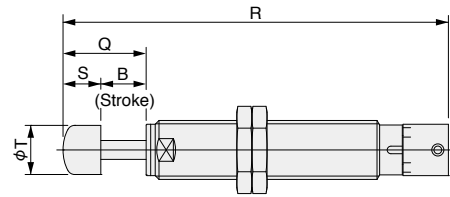
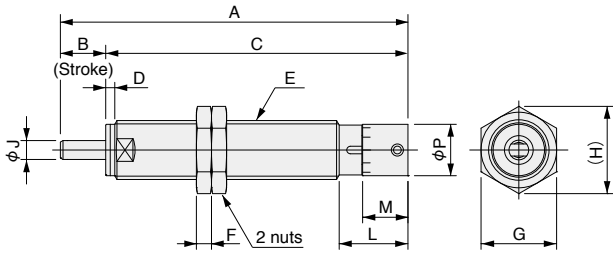

Model	Symbol	A	B	C	D	E	F	G	H	J	L	M	P	Q	R	S	T
KSHP6 × 4 (C)		36	4	32	0.5	M6 × 0.75	2	8	9.2	2	6.5	5.4	5	8	40	4	4.6
KSHP8 × 6 (C)		46	6	40	1.2	M8 × 0.75	2	10	11.5	2.5	9	6	6.8	11	51	5	6.5
KSHP8 × 6 (C)-11		46	6	40	1.2	M8 × 1	3	10	11.5	2.5	9	6	6.8	11	51	5	6.5

● No rod end cap: **KSHP**□ × □

● With rod end cap

With plastic cap: **KSHP**□ × □ **C**

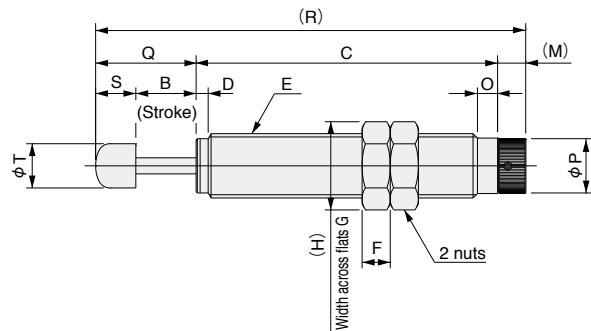
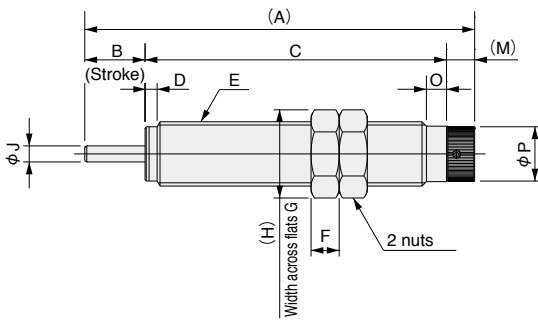

With rubber cap: **KSHP**□ × □ **R**

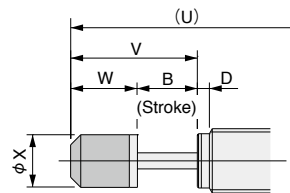

Note: Rubber cap is not available with the **KSHP10 × 8**

With rubber cap: For the **KSHP14 × 12R**

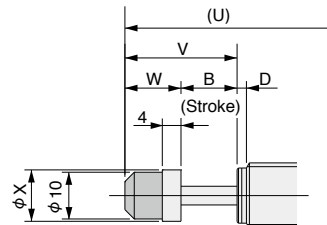

Model	Symbol	A	B	C	D	E	F	G	H	J	M	O	P	Q	R	S	T	U	V	W	X
KSHP10 × 8 (C)		69	8	56	6	M10 × 1	3	12	13.9	3	5	4	8.7	16	77	8	8	-	-	-	-
KSHP12 × 10 (C,R)		75	10	60	2	M12 × 1	4	14	16.2	3	5	4	10.7	20	85	10	10	85	20	10	10
KSHP14 × 12 (C,R)		87	12	70	2	M14 × 1.5	5	17	19.6	4	5	4	10.7	22	97	10	11	99	24	12	11
KSHP16 × 15 (C,R)		97	15	75	3	M16 × 1.5	7	19	21.9	4	7	5	13.5	25	107	10	11	113.5	31.5	16.5	13
KSHP18 × 20 (C,R)		116	20	89	3	M18 × 1.5	8	21	24.2	5	7	5	13.5	35	131	15	15	131.7	35.7	15.7	15
KSHP20 × 22 (C,R)		121	22	92	3	M20 × 1.5	8	24	27.7	5	7	5	17	40	139	18	16	139.2	40.2	18.2	16

Dimensions (mm)

● No rod end cap: **KSHP25 × 25**

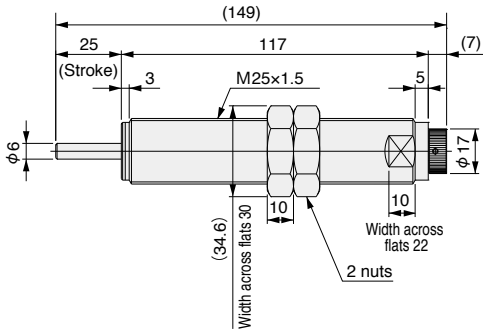

● With rod end cap

With plastic cap: **KSHP25 × 25C**

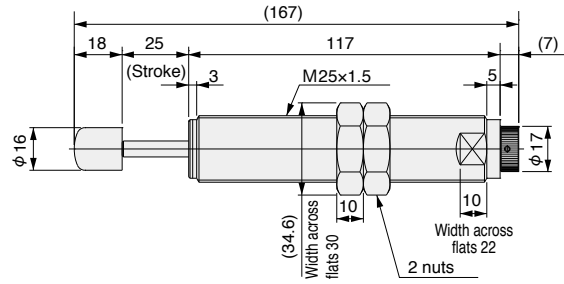

With rubber cap: **KSHP25 × 25R**

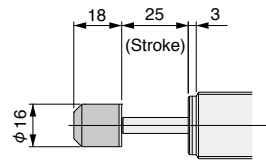

● No rod end cap: **KSHP□ × □**

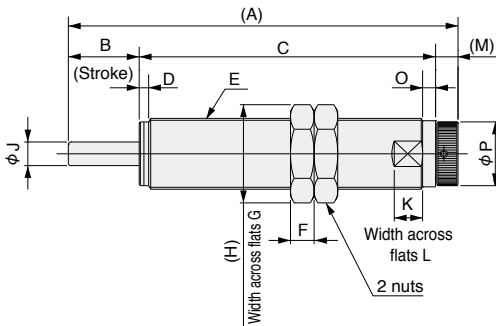

● With rod end cap

With plastic cap: **KSHP□ × □C**

With rubber cap: **KSHP□ × □R**

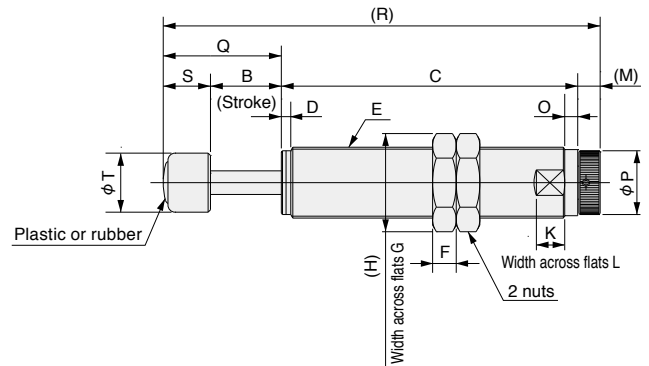

Model	Symbol	A	B	C	D	E	F	G	H	J	K	L	M	O	P	Q	R	S	T
KSHP30 × 30 (C,R)		165	30	125.5	4	M30 × 1.5	10	36	41.6	10	12	28	9.5	5.5	27	50	185	20	25
KSHP36 × 50 (C,R)		229	50	169.5	5	M36 × 1.5	15	46	53.1	12	12	33	9.5	6	27	55	254	25	32
KSHP42 × 50 (C,R)		235.5	50	173	5	M42 × 1.5	15	50	57.7	12	20	38	12.5	7	38	75	260.5	25	32

Mass (Specifications in inches)

Model	Main unit ^{Note1}	Additional mass		Additional parts' mass	
		With plastic cap	With rubber cap	Mounting nut (1 ea.)	Stopper nut
KSHP6 × 4 -F11	0.2	0.007	—	0.04	0.1
KSHP8 × 6 -11-F11	0.5	0.02	—	0.06	0.2
KSHP10 × 8 -F11	0.9	0.02	—	0.07	0.4
KSHP11 × 8 -F11	1.2	0.02	—	0.08	0.4
KSHP12 × 10 -F11	1.7	0.04	0.04	0.1	0.5
KSHP14 × 12 -F11	2.6	0.04	0.06	0.2	0.7
KSHP18 × 20 -F11	5.9	0.1	0.2	0.4	2.5
KSHP25 × 25 -F11	13.2	0.2	0.2	1.1	4.4
KSHP30 × 30 -F11	22.2	1.8	1.7	1.3	5.5
KSHP36 × 50 -F11	35.3	3.9	3.8	3.0	9.8
KSHP42 × 50 -F11	63.0	3.9	3.8	3.4	10.8

Calculation example: The mass of KSHP10x8C-S-2 (with cap and stopper) is

$$0.9 + 0.02 + 0.4 = 1.32\text{oz}$$

Note1: The weight of the main unit includes the weight of 2 mounting nuts.

Note2: KSHP11x8 has only inch specifications.

Order Codes (specifications in inches)

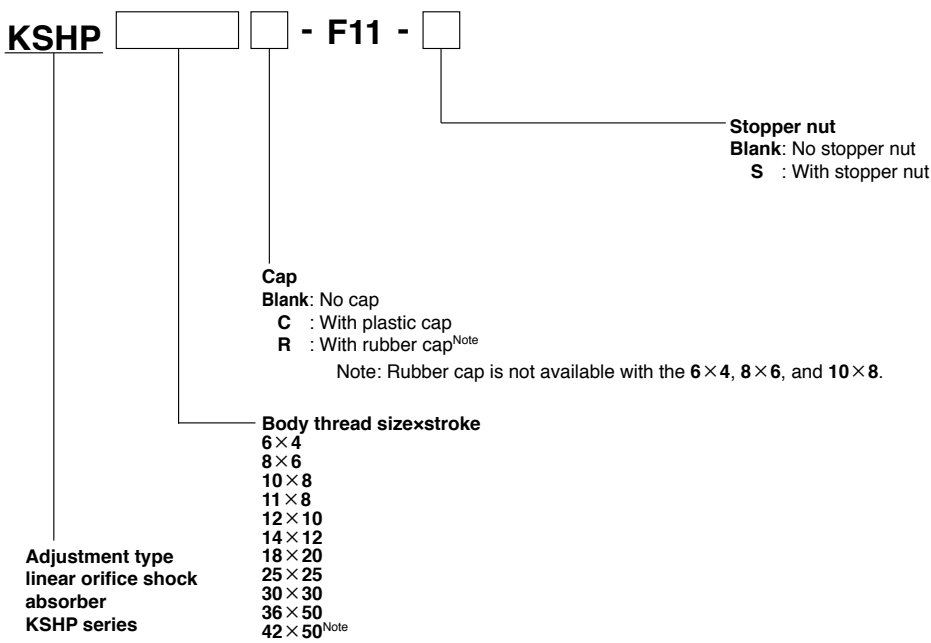

Note: KSHP42 × 50 is a built-to-order product. Contact us about turnaround times, prices, or other information.

Dimensions (in)

● No rod end cap: **KSHP**□ × □

● With rod end cap

With plastic cap: **KSHP**□ × □**C**

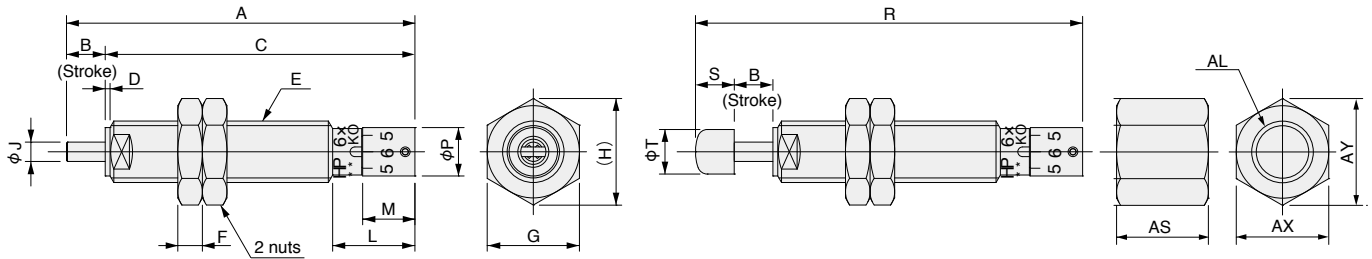

Model	Symbol	A	B	C	D	E	F	G	H	J	L	M	P	R	S
KSHP6 × 4 (C)-F11		1.417	0.157	1.26	0.02	1/4-32 UNEF	0.1	3/8	0.433	0.079	0.335	0.213	0.197	1.575	0.157
KSHP8 × 6 (C)-F11		1.811	0.236	1.575	0.047	5/16-32 UNEF	0.13	7/16	0.505	0.098	0.358	0.236	0.268	2.008	0.197

Model	Symbol	T	AL	AS	AX	AY
KSHP6 × 4 (C)-F11		0.181	1/4-32 UNEF	0.4	3/8	0.433
KSHP8 × 6 (C)-F11		0.256	5/16-32 UNEF	7/16	7/16	0.505

● No rod end cap: **KSHP**□ × □

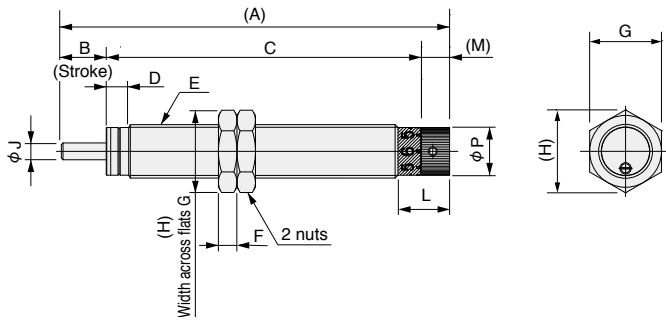

● With rod end cap

With plastic cap: **KSHP**□ × □**C**

With rubber cap: **KSHP**□ × □**R**

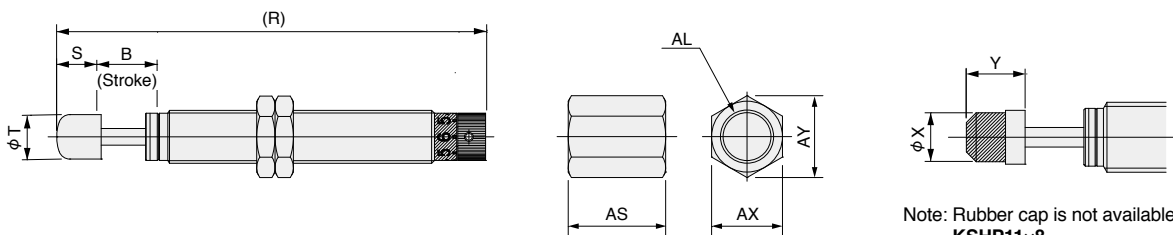

Note: Rubber cap is not available with the **KSHP10×8**, **KSHP11×8**

Model	Symbol	A	B	C	D	E	F	G	H	J	L	M	P	R	S
KSHP10 × 8 (C)-F11		2.724	0.315	2.409	0.157	3/8-32 UNEF	0.13	1/2	0.577	0.118	0.362	0.197	0.335	3.039	0.315
KSHP11 × 8 (C)-F11		2.724	0.315	2.409	0.157	7/16-28 UNEF	0.15	9/16	0.65	0.118	0.362	0.197	0.343	3.039	0.315
KSHP12 × 10 (C,R)-F11		2.961	0.394	2.567	0.157	1/2-20 UNF	0.15	5/8	0.722	0.118	0.362	0.197	0.421	3.354	0.394
KSHP14 × 12 (C,R)-F11		3.433	0.472	2.961	0.157	9/16-18 UNF	7/32	11/16	0.794	0.157	0.362	0.197	0.421	3.827	0.394
KSHP18 × 20 (C,R)-F11		4.575	0.787	3.787	0.197	3/4-16 UNF	1/4	15/16	1.082	0.197	0.48	0.276	0.531	5.165	0.591
KSHP25 × 25 (C,R)-F11		5.874	0.984	4.89	0.197	1-12 UNF	3/8	1 1/4	1.443	0.236	0.48	0.276	0.669	6.583	0.709

Model	Symbol	T	X	Y	AL	AS	AX	AY
KSHP10 × 8 (C)-F11		0.315	-	-	3/8-32 UNEF	11/16	1/2	0.577
KSHP11 × 8 (C)-F11		0.315	-	-	7/16-28 UNEF	11/16	9/16	0.65
KSHP12 × 10 (C,R)-F11		0.394	0.394	0.394	1/2-20 UNF	11/16	5/8	0.722
KSHP14 × 12 (C,R)-F11		0.433	0.433	0.472	9/16-18 UNF	3/4	11/16	0.794
KSHP18 × 20 (C,R)-F11		0.591	0.591	0.618	3/4-16 UNF	1 1/2	15/16	1.082
KSHP25 × 25 (C,R)-F11		0.63	0.63	0.709	1-12 UNF	1 1/2	1 1/4	1.443

Dimensions (in)

● No rod end cap: **KSHP**□ × □

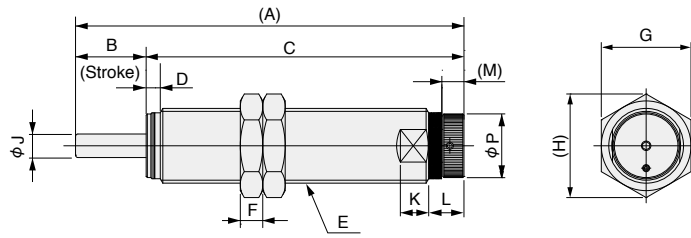

● With rod end cap

With plastic cap: **KSHP**□ × □**C**

With rubber cap: **KSHP**□ × □**R**

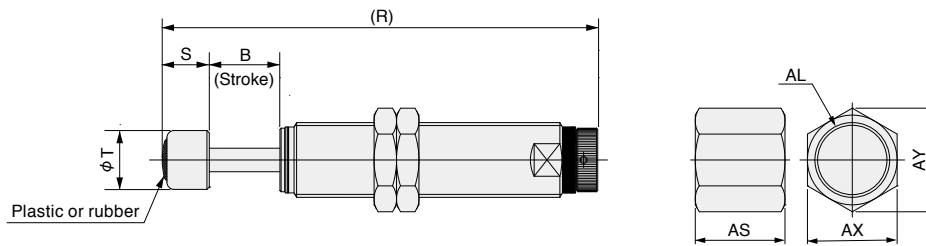

Model	Symbol	A	B	C	D	E	F	G	H	J	K	L	M	P	R	S
KSHP30 × 30 (C,R)-F11		6.496	1.181	5.315	0.236	1 1/4-12 UNF	3/8	1 1/2	1.732	0.394	0.472	0.591	0.354	1.063	7.283	0.787
KSHP36 × 50 (C,R)-F11		9.016	1.969	7.047	0.276	1 3/8-12 UNF	5/8	1 11/16	1.948	0.472	0.472	0.61	0.354	1.063	10	0.984
KSHP42 × 50 (C,R)-F11		9.272	1.969	7.303	0.276	1 3/4-12 UN	5/8	2	2.309	0.472	0.787	0.768	0.472	1.496	10.256	0.984

Model	Symbol	T	AL	AS	AX	AY
KSHP30 × 30 (C,R)-F11		0.984	1 1/4-12 UNF	1 1/2	1 1/2	1.732
KSHP36 × 50 (C,R)-F11		1.26	1 3/8-12 UNF	2	1 11/16	1.948
KSHP42 × 50 (C,R)-F11		1.26	1 3/4-12 UN	2	2	2.309

KSHJ

KSHY

KSHP

KSHC

Additional Parts