



Koganei Clean System products provide complete support for the maintenance of a clean environment inside the cleanroom.

Koganei Clean System products meet the needs of the ultra-clean production environment. In everything from actuators and valves to air preparation and auxiliary equipment, anti-corrosion materials processing and other Koganei-developed design concepts serve to prevent particle contamination within the cleanroom. These perfectly designed mechanisms, which resolve even the slightest leaks to the outside during operations, have already won a high level of reliability.

Koganei Cleanliness

There is currently no standard in JIS or elsewhere for methods of evaluating cleanliness for pneumatic equipment in the cleanroom specifications. Therefore, to measure the effects of cleanroom contamination by pneumatic equipment, Koganei has decided to use “number of particles generated per 10 operations,” rather than particle density. Koganei has also developed classifications for application classes in cleanroom, based on JIS and other upper limit density tables, and on the company’s own experience.

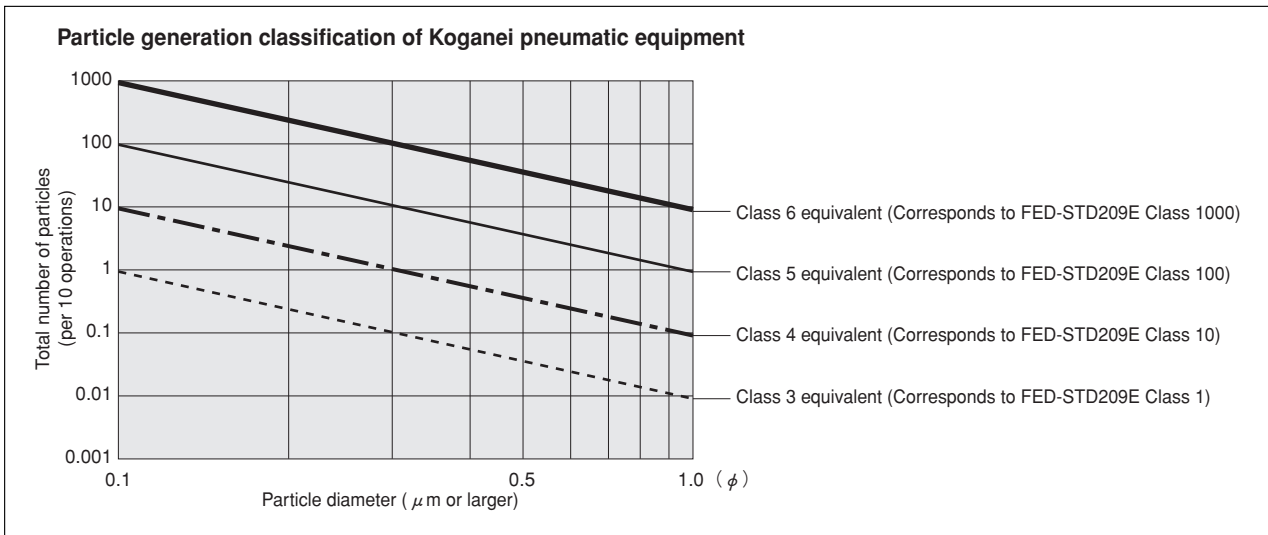

- Remarks:
1. In the above table, product performance in terms of the number of particles generated per 10 operations is expressed as the upper limit of particles corresponding to the equivalent JIS or ISO class.
 2. In the above table, values in the JIS, ISO, and FED-STD upper limit density tables are calculated as upper density per liter.
 3. The classes shown are clean levels as classified in JIS and ISO.

From the above definitions, the Koganei clean level classes can be viewed as the level of average contamination per liter of surrounding air over a period of 10 operations in cleanroom. Air ventilation in cleanrooms is usually faster than 1 cycle per minute, and clean volumetric capacity is usually larger than 1 liter, which should provide a sufficient safety margin in practice.

Caution: The above conclusions are based on an ideal situation in which air ventilation is being implemented. For specific cases where air ventilation is not ensured, caution is needed since the clean classes cannot be maintained.

The clean system diagrams shown here are for Class 5 equivalent products. For Class 4 or Class 3 equivalent products, consult us.

Evaluations of Cleanliness

Koganei has therefore specified its in-house measurement methods, to conduct evaluations on the cleanroom rating.

The number of particles of the Air Cylinder Cleanroom Specification is measured as shown in the method below.

1. Measurement conditions

1-1 Test circuit: Figure 1 (no suction), Figure 2 (with suction)

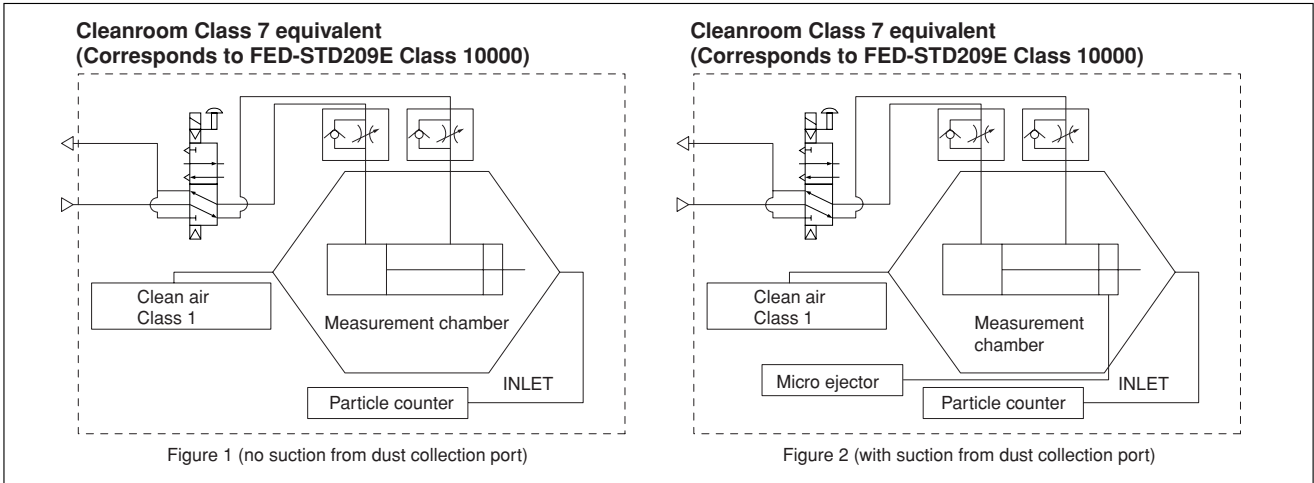

1-2 Operating conditions of tested cylinder

- Operating frequency: 1Hz
- Average speed: 500mm/s [20in./sec.]
- Applied pressure: 0.5MPa [73psi.]
- Suction condition: Microejector ME05, Primary side: 0.5MPa [73psi.] applied, Tube: $\phi 6$ [0.236in.]
- Mounting direction: Vertical
- Chamber volume: 8.3 ℓ [0.293ft.³]

2. Particle counter

- Manufacturer/model: RION/KM20
- Suction flow rate: 28.3 ℓ /min [1ft.³/min.]
- Particle diameter: 0.1 μm , 0.2 μm , 0.3 μm , 0.5 μm , 0.7 μm , 1.0 μm

3. Measurement method

- 3-1 Confirmation of number of particles in the measurement system
Under the conditions in the above 1 and 2, using a particle counter to measure the sample for 9 minutes without operating the measurement sample, and confirmed the measured number of particle is 1 piece or less.
- 3-2 Measurement under operation
Under the conditions in the above 1 and 2, operating the measurement sample for 36 minutes, and measured the total values in the latter half of 18 minutes test.
- 3-3 Reconfirmation
Performed the measurement in 3-1 again, to reconfirm the number of particles in the measurement system.

4. Measurement results

● Cleanroom specification

Jig Cylinder (no suction from dust collection port)

Particle generation over 1 million operations (CS-CDA16 \times 30)

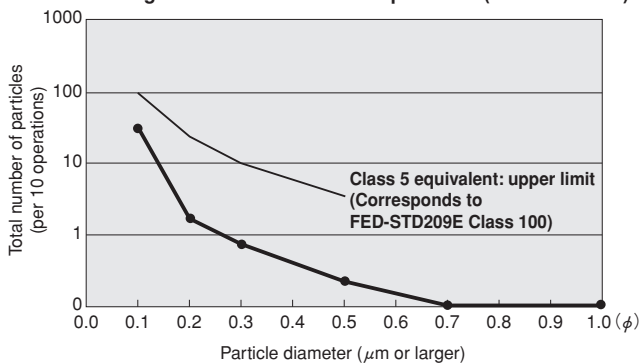

● Cleanroom specification

Slim Cylinder (with suction from dust collection port)

Particle generation over 1 million operations (CS-DA20 \times 100)

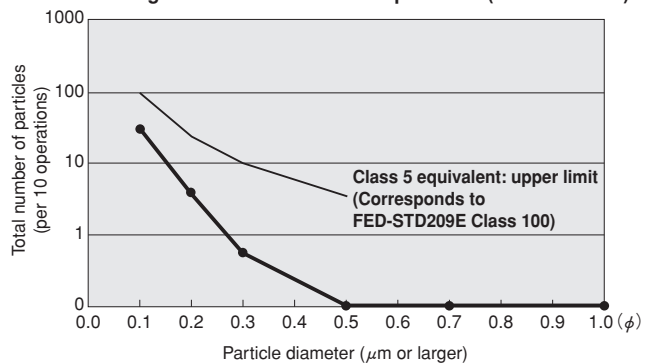

For “safety precautions” listed in the Clean System Product Drawings, see the materials below.

- For actuators, see “Safety Precautions” on p. 45 of the Actuators General Catalog .
- For valves, see “Safety Precautions” on p. 31 of the Valves General Catalog.
- For air treatment and auxiliary equipment, see “Safety Precautions” on p.31 of the General Catalog of Air Treatment, Auxiliary, Vacuum.

KOGANEI CLEAN SYSTEM SOLENOID VALVES EA SERIES

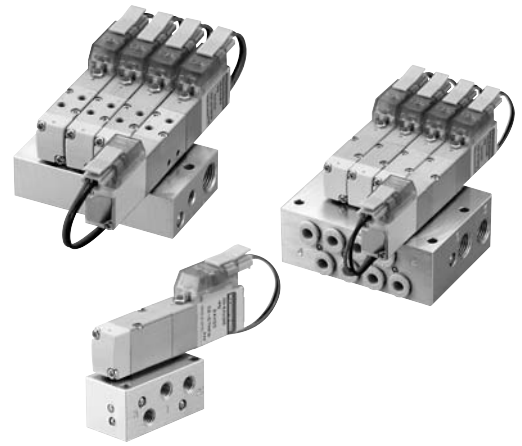

Symbols

single solenoid
5-port

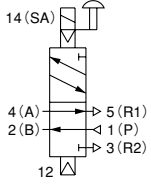

Double solenoid
5-port

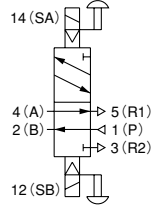

Specifications

Basic Models and Functions

Basic model	For direct piping, FE type manifold	CS-EA10□F1 ^{Note} CS-EA10□F2 ^{Note} CS-EA10□F3 ^{Note} CS-EA10□F4 ^{Note}	CS-EA10□F5	CS-EA10□F6
	For base piping, A, AJ type manifolds	CS-EA10□A1 ^{Note} CS-EA10□A2 ^{Note} CS-EA10□A3 ^{Note} CS-EA10□A4 ^{Note}	CS-EA10□A5	CS-EA10□A6
Item				
Number of positions		2 positions		
Number of ports		2, 3 ports	5 ports	
Valve function		Single solenoid NC, NO	Single solenoid	Double solenoid

Remark: For the optional specifications and order codes, see p.157.

Note: Valves with valve specifications F1, F2, F3, F4, A1, A2, A3, and A4 are for mounting on manifolds only, and cannot be used as single valve units.

Port Size

Specification	Port	2(B), 4(A)	1(P)	3, 5(R)	PR
Single unit	Direct piping	M3×0.5	M3×0.5	M3×0.5	—
	Base piping (with sub-base)	M5×0.8	M5×0.8	M5×0.8	M5×0.8
Manifold	FE type	M3×0.5	M5×0.8	Rc1/8	—
	A type	M5×0.8	Rc1/8	Rc1/8	Collected at 3, 5 (R) port
	AJ type	Quick fitting for $\phi 4$	Rc1/8	Rc1/8	

Specifications

Basic model	For direct piping, FE type manifold	CS-EA10□F1 CS-EA10□F2 CS-EA10□F3 CS-EA10□F4	CS-EA10□F5	CS-EA10□F6
	For base piping, A, AJ type manifolds	CS-EA10□A1 CS-EA10□A2 CS-EA10□A3 CS-EA10□A4	CS-EA10□A5	CS-EA10□A6
Item				
Media	Air			
Operation type	Internal pilot type			
Flow rate characteristics	Sonic conductance C $\text{dm}^3/(\text{s} \cdot \text{bar})$	Base piping (A, AJ types): 0.26		
	Effective area S $[\text{Cv}] \text{ mm}^2$	Direct piping (FE type): 1.3 {0.07}		
Port size ^{Note 1}	M3×0.5			
Lubrication	Not required			
Operating pressure range	MPa [psi.]	0.2~0.7 [29~102]		
Proof pressure	MPa [psi.]	1.05 [152]		
Response time ^{Note 2} ON/OFF	Standard type	10/20 or below	12 or below	
	Low current type (L)	10/50 or below	12 or below	
	Quick response type (S)	6/7 or below	6 or below	
Maximum operating frequency	Standard type	5		
	Low current type (L)	2		
	Quick response type (S)	10		
Minimum time to energize for self holding ^{Note 3}	ms	—	50	
Operating temperature range (atmosphere and media)	°C [°F]	5~50 [41~122]		
Shock resistance	m/s^2 {G}	1373.0 {140} (Axial direction 294.2 {30})	1373.0 {140} (Axial direction 147.1 {15})	
Mounting direction		Any		

- Notes: 1. For details, see the port size on p.154.
 2. Values when air pressure is 0.5MPa [73psi].
 3. For double solenoid valves.

Solenoid Specifications

Item	Rated voltage	DC12V	DC24V	DC24V	DC24V	
		(Standard type)	(Standard type)	(Low current type)	(Quick response type)	
Operating voltage range	V	10.8~13.2 (12±10%)	21.6~26.4 (24±10%)	21.6~26.4 (24±10%)	21.6~26.4 (24±10%)	
Standard type	Current (when rated voltage is applied) mA (r.m.s)	46	23	—	—	
	Power consumption W	0.55	0.55	—	—	
Low current type Quick response type	Current (when rated voltage is applied)	Starting mA	—	23	125	
		Holding mA	—	—	6.3	46
	Power consumption	Starting W	—	—	0.55	3
		Holding W	—	—	0.15	1.1
	Start-up time (standard time) ms	—	—	200 or below	30 or below	
Allowable leakage current	mA	2	1	0.5	4	
Insulation resistance	MΩ	Over 100 (value at DC500V megger)				
Color of LED indicator		Red				
Surge suppression (as standard)		Flywheel diode				

5-port, 2-position

Single solenoid
CS-EA10F5
De-energized

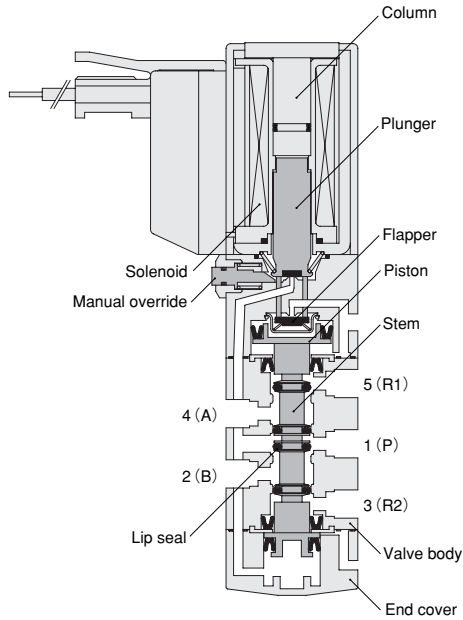

Double solenoid
CS-EA10F6
[De-energized condition after energizing solenoid 12(SB)]

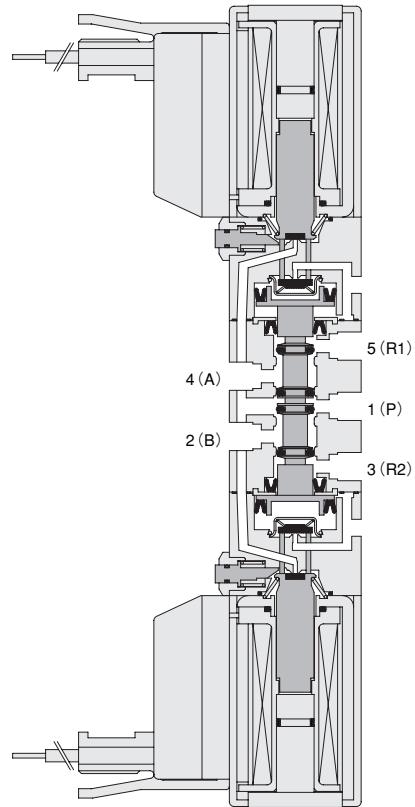

Major Parts and Materials

	Parts	Materials
Valve	Body	Aluminum alloy (anodized)
	Stem	
	Lip seal	Synthetic rubber
	Flapper	
	Mounting base	Mild steel (zinc plated)
	Sub-base	Aluminum alloy (anodized)
	Plunger	Magnetic stainless steel
	Column	
End cover	Plastic	
Manifold	Body	Aluminum alloy (anodized)
	Block-off plate	Mild steel (nickel plated)
	Seal	Synthetic rubber

EA Series Single Valve Unit for Manifold/Sub-base Order Codes



Model

CS-EA10

Standard type

CS-EA10L

Low current type

CS-EA10S

Quick response type

Valve specification

F1, A1: 2-port normally closed (NC)^{Note1}

F2, A2: 2-port normally open (NO)^{Note1}

F3, A3: 3-port normally closed (NC)^{Note1}

F4, A4: 3-port normally open (NO)^{Note1}

F5, A5: 5-port 2-position, single solenoid

F6, A6: 5-port 2-position, double solenoid

Sub-base

Without sub-base

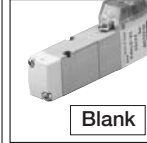

With sub-base



Manual override

Blank: Non-locking type

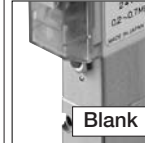

-83: Locking protruding type

Wiring specification

S type plug connector
Lead wire 300mm [11.8in.]



L type plug connector
Lead wire 300mm [11.8in.]



S type plug connector
Lead wire 1000mm [39in.]



L type plug connector
Lead wire 1000mm [39in.]



S type plug connector
Lead wire 3000mm [118in.]



L type plug connector
Lead wire 3000mm [118in.]



S type plug connector
Without connector ass'y



L type plug connector
Without connector ass'y



Grommet type^{Note3}
Lead wire 300mm [11.8in.]
(moisture proof specification)

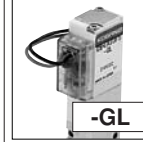

Voltage

-D4

DC24V

-D5

DC12V^{Note4}

	Model	Valve specification	Sub-base	Manual override	Wiring specification	Voltage
Direct piping	CS-EA10 CS-EA10L CS-EA10S	F1 ^{Note1} F2 ^{Note1} F3 ^{Note1} F4 ^{Note1} F5 ^{Note1} F6 ^{Note1}		Blank -83 ^{Note2}	-PS -PS1 -PS3 -PSN -PL -PL1 -PL3 -PLN -GL ^{Note3}	-D4 -D5 ^{Note4}
Base piping	CS-EA10 CS-EA10L CS-EA10S	A1 ^{Note1} A2 ^{Note1} A3 ^{Note1} A4 ^{Note1} A5 A6	Blank -25	Blank -83 ^{Note2}	-PS -PS1 -PS3 -PSN -PL -PL1 -PL3 -PLN -GL ^{Note3}	-D4 -D5 ^{Note4}

Notes: 1. Valves with valve specifications F1, F2, F3, F4, F5, F6, A1, A2, A3, and A4 are for mounting on manifolds only, and cannot be used as single valve units.

2. The locking protruding type manual override is not available in the quick response type CS-EA10S.

3. The grommet type is not available in the low current type CS-EA10L and quick response type CS-EA10S.

4. The DC12V specification is not available in the low current type CS-EA10L and quick response type CS-EA10S.

EA Series Additional Parts Order Codes

Block-off plate (block-off plate, gasket, and 2 mounting screws)

CS-EABP -

Specification
FE : For FE type manifold
A : For A, AJ type manifolds

Connector-related

EAZ -

Connector specification
P : Connector, lead wire length 300mm [11.8in.]
P1 : Connector, lead wire length 1000mm [39in.]
P3 : Connector, lead wire length 3000mm [118in.]
PN : Connector, without lead wire (contacts included)

Common connector assembly

EAZ -

Connector specification
PA : Positive common A type, connector, lead wire length 300mm [11.8in.]
PA1 : Positive common A type, connector, lead wire length 1000mm [39in.]
PA3 : Positive common A type, connector, lead wire length 3000mm [118in.]
PB : Positive common B type, connector, lead wire length 300mm [11.8in.]
PB1 : Positive common B type, connector, lead wire length 1000mm [39in.]
PB3 : Positive common B type, connector, lead wire length 3000mm [118in.]
PC : Positive common C type, connector, lead wire length 300mm [11.8in.]
PC1 : Positive common C type, connector, lead wire length 1000mm [39in.]
PC3 : Positive common C type, connector, lead wire length 3000mm [118in.]
CPN : Positive common, connector, without lead wire (short bar and contacts included)

A type: EAZ-PA*



B type: EAZ-PB*

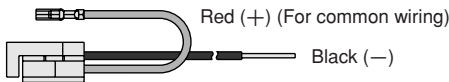

C type: EAZ-PC*

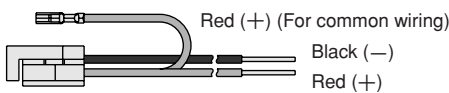

※Lead wire length **Blank** : 300mm [11.8in.]:
1 : 1000mm [39in.]
3 : 3000mm [118in.]

Application example

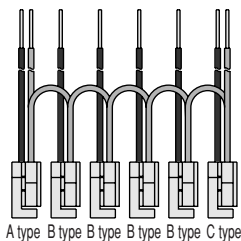

Dimensions of EA Series Solenoid Valve mm [in.]

5-port, single solenoid (with sub-base)

CS-EA10 □ A5-25-PL

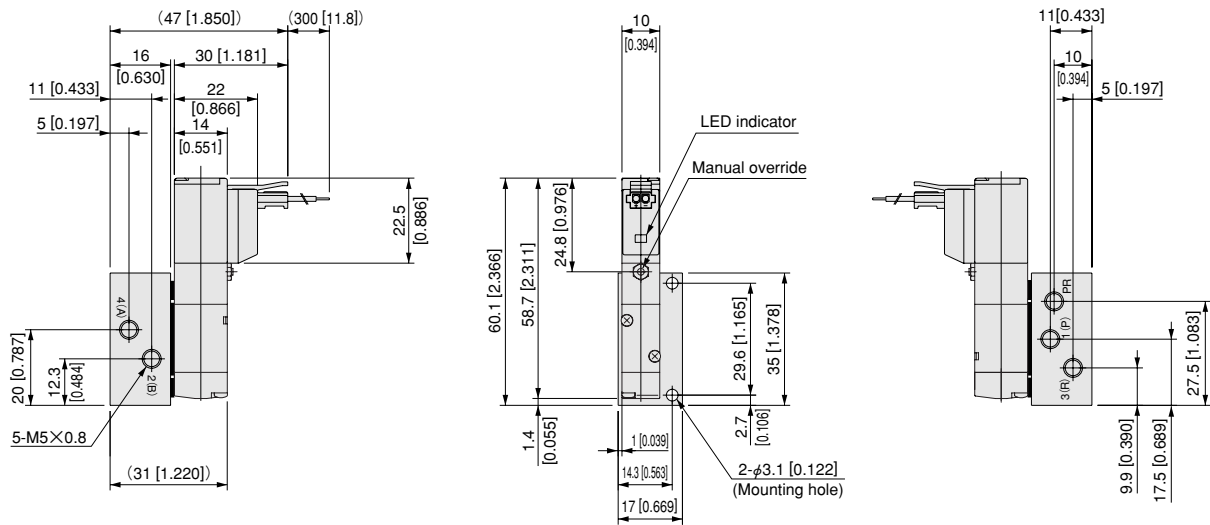

Options

● Locking protruding type manual override: **-83**

● Grommet: **-GL**

● S type plug connector: **-PS**

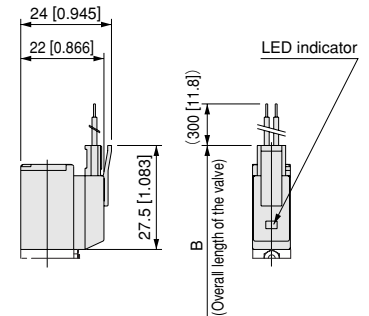
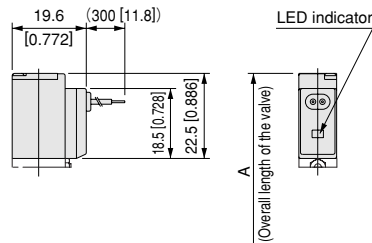
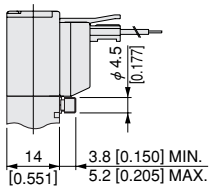

Model	Code	A	B	Remark
CS-EA10F1 ~ CS-EA10F5, CS-EA10A1 ~ CS-EA10A5		58.7 [2.311]	63.7 [2.508]	
CS-EA10LF1 ~ CS-EA10LF5, CS-EA10LA1 ~ CS-EA10LA5		—	63.7 [2.508]	Overall length to the end of the valve
CS-EA10SF1 ~ CS-EA10SF5, CS-EA10SA1 ~ CS-EA10SA5		—	63.7 [2.508]	

Dimensions of EA Series Solenoid Valve mm [in.]

5-port, double solenoid (with sub-base)

CS-EA10 □ **A6-25-PL**

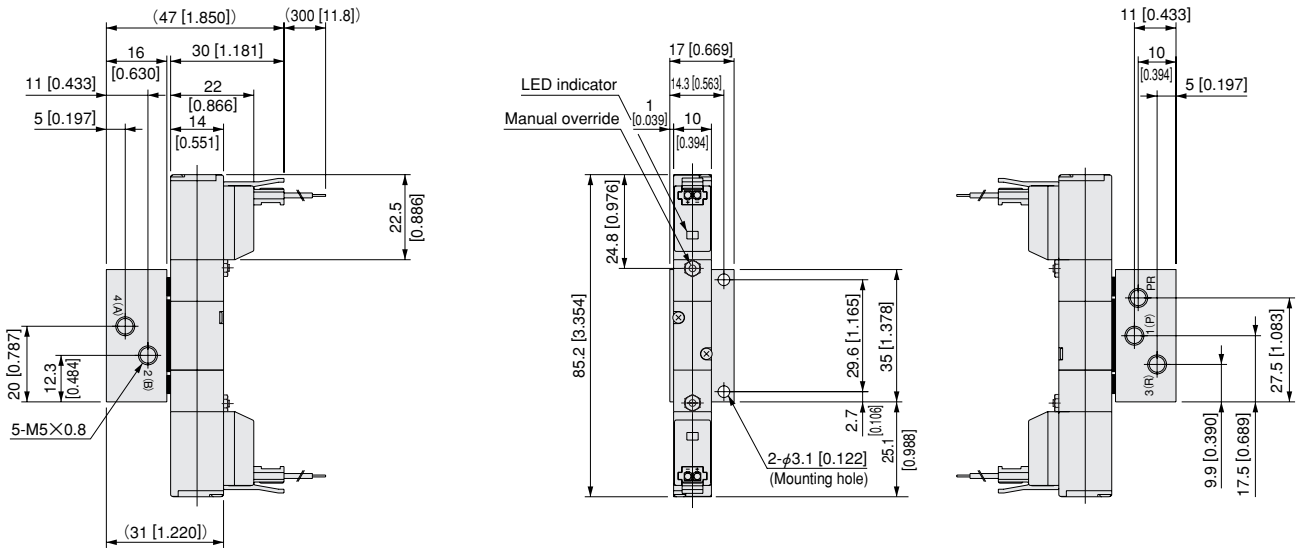

Options

● Locking protruding type manual override: **-83**

● Grommet: **-GL**

● S type plug connector: **-PS**

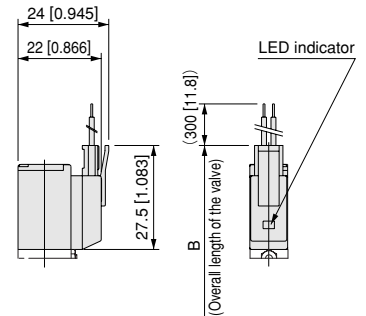
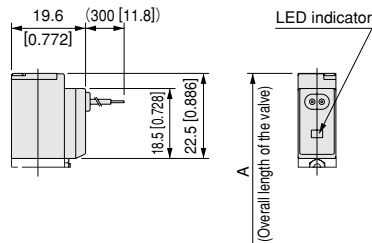
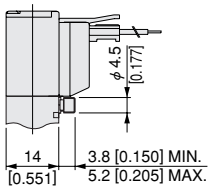

Model	Code	A	B	Remark
CS-EA10F6, CS-EA10A6		85.2 [3.354]	95.2 [3.748]	
CS-EA10LF6, CS-EA10LA6		—	95.2 [3.748]	Overall length to the end of the solenoid on the opposite side
CS-EA10SF6, CS-EA10SA6		—	95.2 [3.748]	

Dimensions of EA Series Manifold mm [in.]

Manifold for combination mounting of 2, 3, 5-port valves

CS-EAM□FE

(Direct piping type)

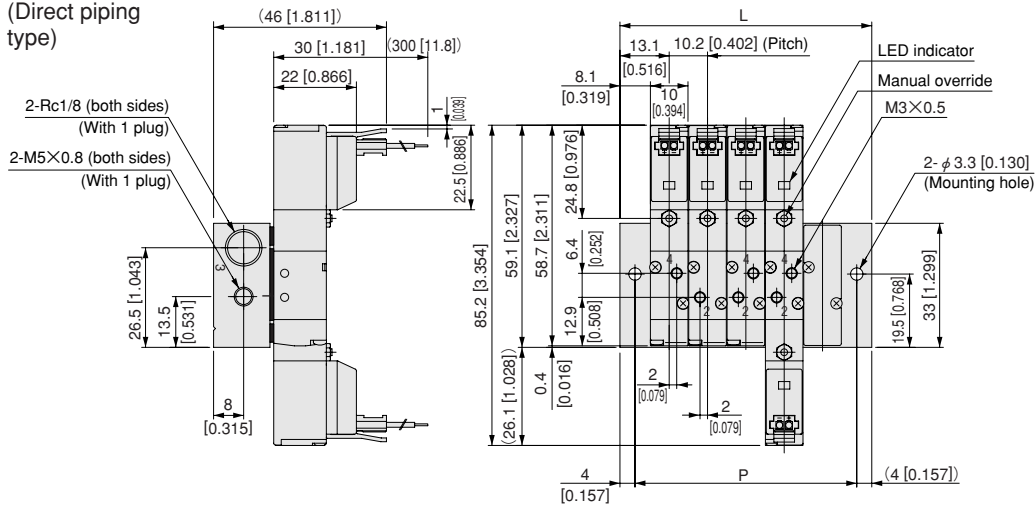

[Installation example]

CS-EAM5FE

- stn.1 CS-EA10F3-PL-D4
- stn.2 CS-EA10F4-PL-D4
- stn.3 CS-EA10F5-PL-D4
- stn.4 CS-EA10F6-PL-D4
- stn.5 CS-EABP-F

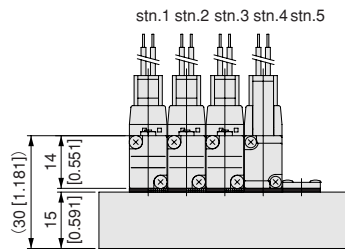

CS-EAM□A

(Base piping type)

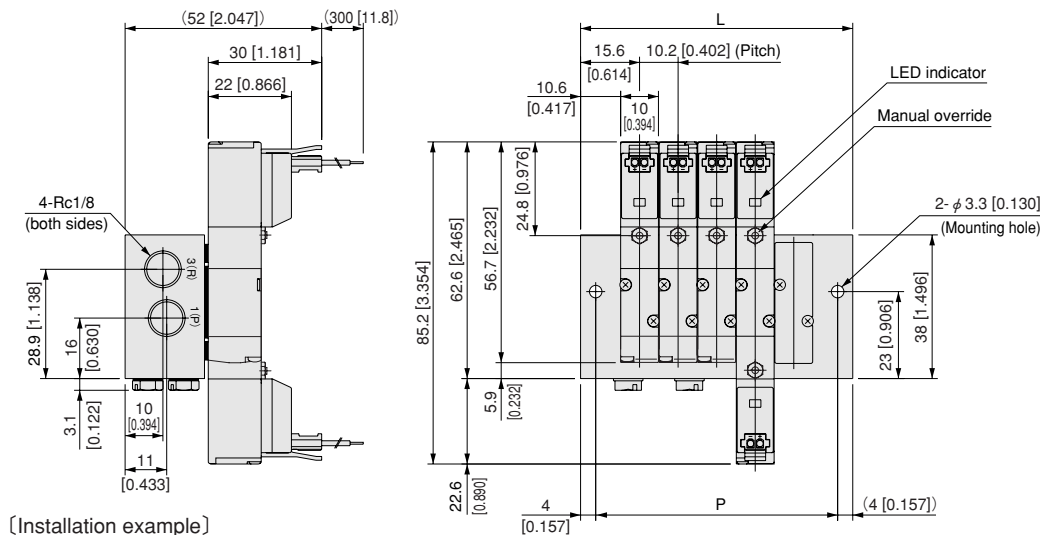

[Installation example]

CS-EAM5A

- stn.1 CS-EA10A3-PL-D4
- stn.2 CS-EA10A4-PL-D4
- stn.3 CS-EA10A5-PL-D4
- stn.4 CS-EA10A6-PL-D4
- stn.5 CS-EABP-A

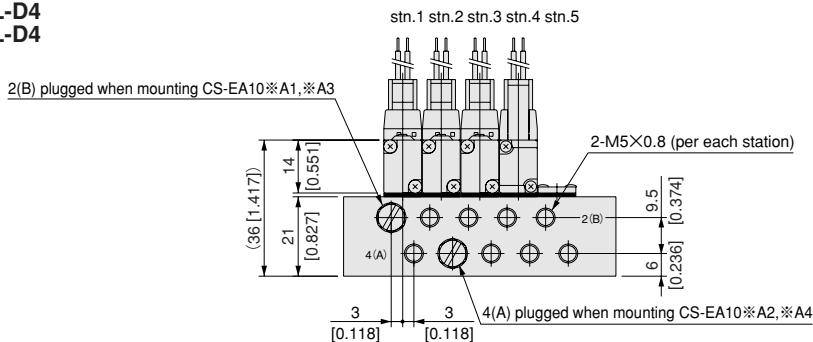

Unit dimensions

No. of units	L	P
2	36.4 [1.433]	28.4 [1.118]
3	46.6 [1.835]	38.6 [1.520]
4	56.8 [2.236]	48.8 [1.921]
5	67.0 [2.638]	59.0 [2.323]
6	77.2 [3.039]	69.2 [2.724]
7	87.4 [3.441]	79.4 [3.126]
8	97.6 [3.843]	89.6 [3.528]
9	107.8 [4.244]	99.8 [3.929]
10	118.0 [4.646]	110.0 [4.331]
11	128.2 [5.047]	120.2 [4.732]
12	138.4 [5.449]	130.4 [5.134]
13	148.6 [5.850]	140.6 [5.535]
14	158.8 [6.252]	150.8 [5.937]
15	169.0 [6.654]	161.0 [6.339]
16	179.2 [7.055]	171.2 [6.740]
17	189.4 [7.457]	181.4 [7.142]
18	199.6 [7.858]	191.6 [7.543]
19	209.8 [8.260]	201.8 [7.945]
20	220.0 [8.661]	212.0 [8.346]

Unit dimensions

No. of units	L	P
2	41.4 [1.630]	33.4 [1.315]
3	51.6 [2.031]	43.6 [1.717]
4	61.8 [2.433]	53.8 [2.118]
5	72.0 [2.835]	64.0 [2.520]
6	82.2 [3.236]	74.2 [2.921]
7	92.4 [3.638]	84.4 [3.323]
8	102.6 [4.039]	94.6 [3.724]
9	112.8 [4.441]	104.8 [4.126]
10	123.0 [4.843]	115.0 [4.528]
11	133.2 [5.244]	125.2 [4.929]
12	143.4 [5.646]	135.4 [5.331]
13	153.6 [6.047]	145.6 [5.732]
14	163.8 [6.449]	155.8 [6.134]
15	174.0 [6.850]	166.0 [6.535]
16	184.2 [7.252]	176.2 [6.937]
17	194.4 [7.654]	186.4 [7.339]
18	204.6 [8.055]	196.6 [7.740]
19	214.8 [8.457]	206.8 [8.142]
20	225.0 [8.858]	217.0 [8.543]

Dimensions of EA Series Manifold mm [in.]

Manifold for combination mounting of 2, 3, 5-port valves

CS-EAM□AJ

(Base piping type with quick fittings)

Unit dimensions

No. of units	L	P
2	41.4 [1.630]	33.4 [1.315]
3	51.6 [2.031]	43.6 [1.717]
4	61.8 [2.433]	53.8 [2.118]
5	72.0 [2.835]	64.0 [2.520]
6	82.2 [3.236]	74.2 [2.921]
7	92.4 [3.638]	84.4 [3.323]
8	102.6 [4.039]	94.6 [3.724]
9	112.8 [4.441]	104.8 [4.126]
10	123.0 [4.843]	115.0 [4.528]
11	133.2 [5.244]	125.2 [4.929]
12	143.4 [5.646]	135.4 [5.331]
13	153.6 [6.047]	145.6 [5.732]
14	163.8 [6.449]	155.8 [6.134]
15	174.0 [6.850]	166.0 [6.535]
16	184.2 [7.252]	176.2 [6.937]
17	194.4 [7.654]	186.4 [7.339]
18	204.6 [8.055]	196.6 [7.740]
19	214.8 [8.457]	206.8 [8.142]
20	225.0 [8.858]	217.0 [8.543]

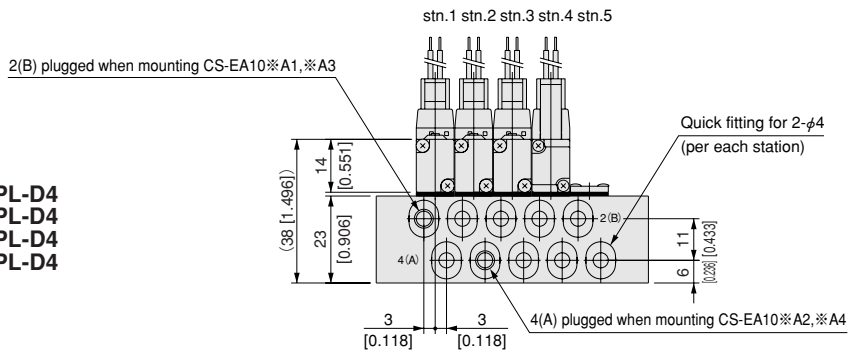
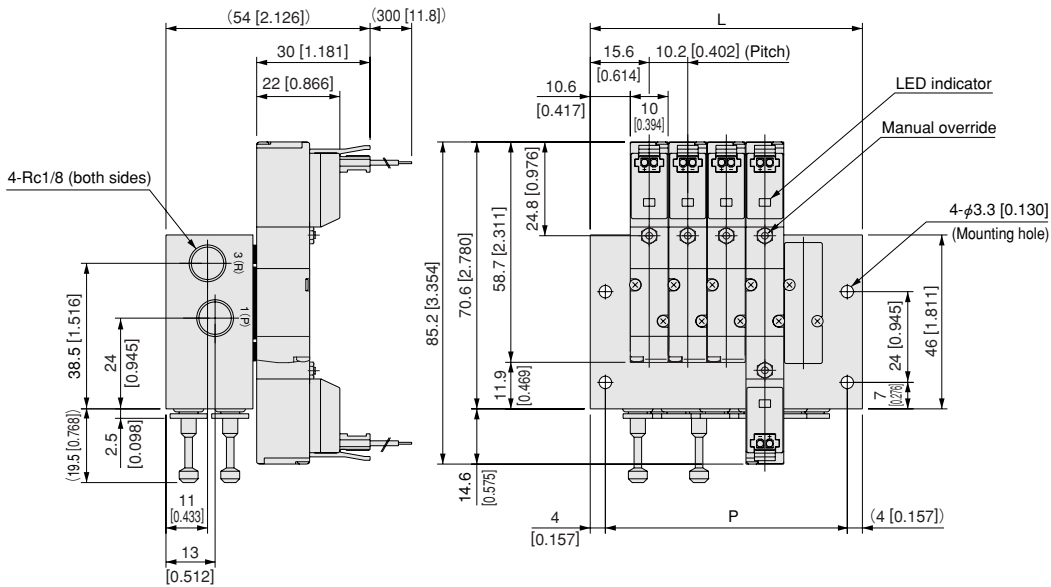

[Installation example]

CS-EAM5AJ

- stn.1 CS-EA10A3-PL-D4
- stn.2 CS-EA10A4-PL-D4
- stn.3 CS-EA10A5-PL-D4
- stn.4 CS-EA10A6-PL-D4
- stn.5 CS-EABP-A



Koganei Clean System products provide complete support for the maintenance of a clean environment inside the cleanroom.

Koganei Clean System products meet the needs of the ultra-clean production environment. In everything from actuators and valves to air preparation and auxiliary equipment, anti-corrosion materials processing and other Koganei-developed design concepts serve to prevent particle contamination within the cleanroom. These perfectly designed mechanisms, which resolve even the slightest leaks to the outside during operations, have already won a high level of reliability.

Koganei Cleanliness

There is currently no standard in JIS or elsewhere for methods of evaluating cleanliness for pneumatic equipment in the cleanroom specifications. Therefore, to measure the effects of cleanroom contamination by pneumatic equipment, Koganei has decided to use “number of particles generated per 10 operations,” rather than particle density. Koganei has also developed classifications for application classes in cleanroom, based on JIS and other upper limit density tables, and on the company’s own experience.

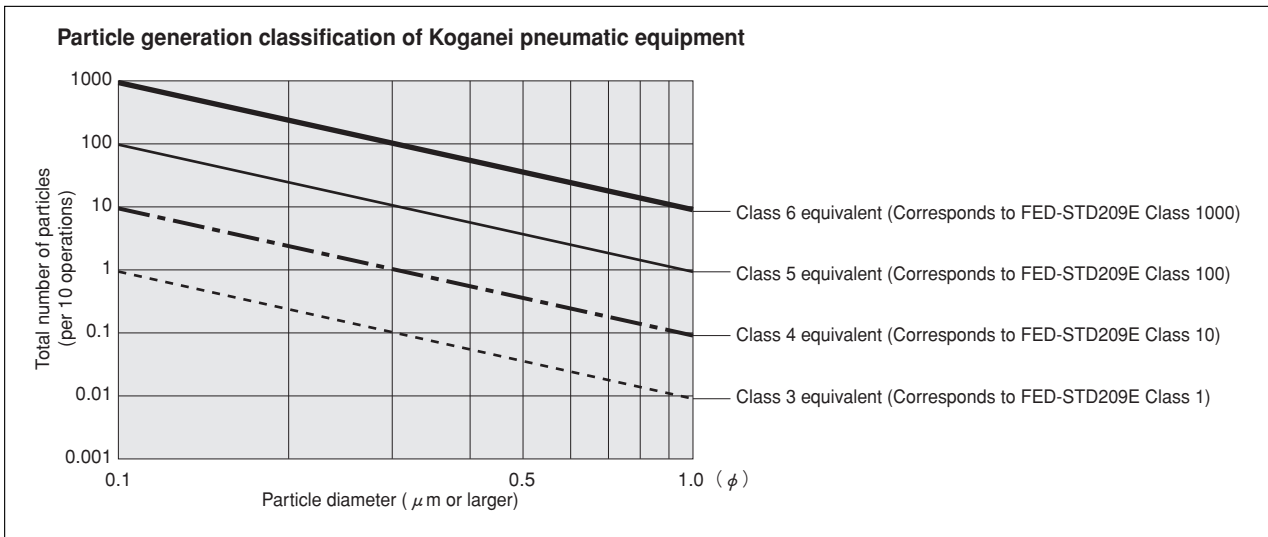

- Remarks:
1. In the above table, product performance in terms of the number of particles generated per 10 operations is expressed as the upper limit of particles corresponding to the equivalent JIS or ISO class.
 2. In the above table, values in the JIS, ISO, and FED-STD upper limit density tables are calculated as upper density per liter.
 3. The classes shown are clean levels as classified in JIS and ISO.

From the above definitions, the Koganei clean level classes can be viewed as the level of average contamination per liter of surrounding air over a period of 10 operations in cleanroom. Air ventilation in cleanrooms is usually faster than 1 cycle per minute, and clean volumetric capacity is usually larger than 1 liter, which should provide a sufficient safety margin in practice.

Caution: The above conclusions are based on an ideal situation in which air ventilation is being implemented. For specific cases where air ventilation is not ensured, caution is needed since the clean classes cannot be maintained.

The clean system diagrams shown here are for Class 5 equivalent products. For Class 4 or Class 3 equivalent products, consult us.

Evaluations of Cleanliness

Koganei has therefore specified its in-house measurement methods, to conduct evaluations on the cleanroom rating.

The number of particles of the Air Cylinder Cleanroom Specification is measured as shown in the method below.

1. Measurement conditions

1-1 Test circuit: Figure 1 (no suction), Figure 2 (with suction)

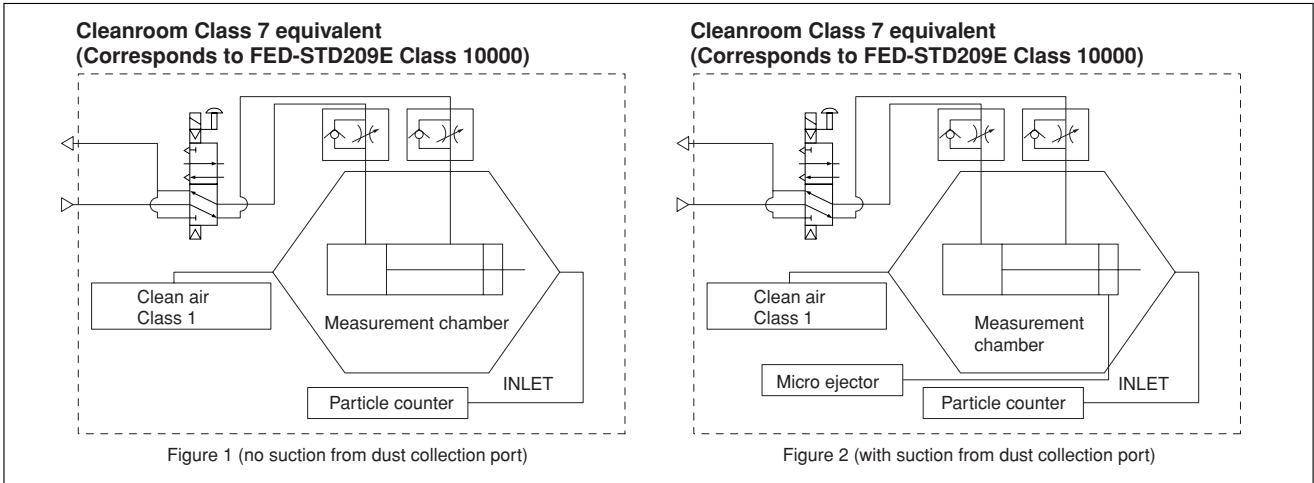

1-2 Operating conditions of tested cylinder

- Operating frequency: 1Hz
- Average speed: 500mm/s [20in./sec.]
- Applied pressure: 0.5MPa [73psi.]
- Suction condition: Microejector ME05, Primary side: 0.5MPa [73psi.] applied, Tube: $\phi 6$ [0.236in.]
- Mounting direction: Vertical
- Chamber volume: 8.3 ℓ [0.293ft.³]

2. Particle counter

- Manufacturer/model: RION/KM20
- Suction flow rate: 28.3 ℓ /min [1ft.³/min.]
- Particle diameter: 0.1 μm , 0.2 μm , 0.3 μm , 0.5 μm , 0.7 μm , 1.0 μm

3. Measurement method

- 3-1 Confirmation of number of particles in the measurement system
Under the conditions in the above 1 and 2, using a particle counter to measure the sample for 9 minutes without operating the measurement sample, and confirmed the measured number of particle is 1 piece or less.
- 3-2 Measurement under operation
Under the conditions in the above 1 and 2, operating the measurement sample for 36 minutes, and measured the total values in the latter half of 18 minutes test.
- 3-3 Reconfirmation
Performed the measurement in 3-1 again, to reconfirm the number of particles in the measurement system.

4. Measurement results

● Cleanroom specification

Jig Cylinder (no suction from dust collection port)

Particle generation over 1 million operations (CS-CDA16 \times 30)

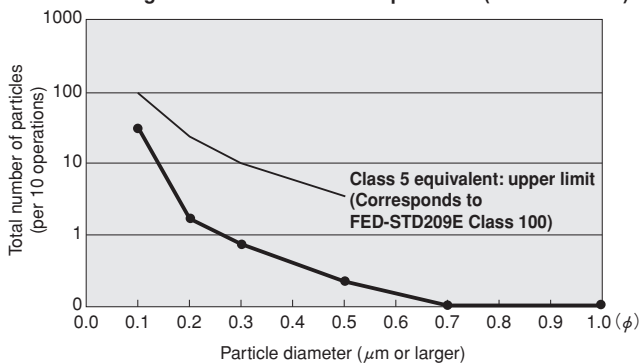

● Cleanroom specification

Slim Cylinder (with suction from dust collection port)

Particle generation over 1 million operations (CS-DA20 \times 100)

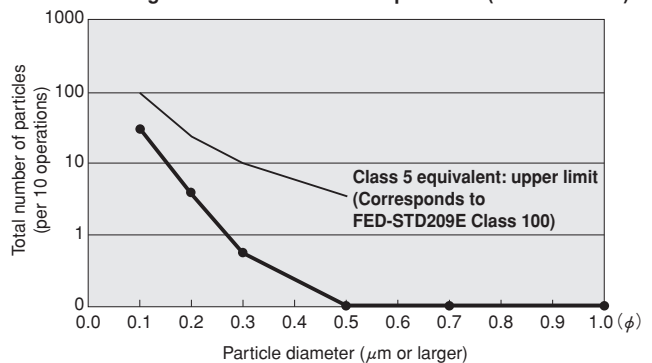

For “safety precautions” listed in the Clean System Product Drawings, see the materials below.

- For actuators, see “Safety Precautions” on p. 45 of the Actuators General Catalog .
- For valves, see “Safety Precautions” on p. 31 of the Valves General Catalog.
- For air treatment and auxiliary equipment, see “Safety Precautions” on p.31 of the General Catalog of Air Treatment, Auxiliary, Vacuum.

Symbols

Single solenoid
2-port Normally closed (NC)

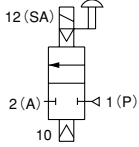

Single solenoid
2-port Normally open (NO)

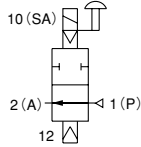

Single solenoid
3-port Normally closed (NC)

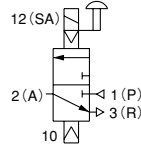

Single solenoid
3-port Normally open (NO)

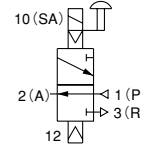

Specifications

Basic Models and Functions

Basic model	For direct piping, FE type manifold	CS-EB10□F1 CS-EB10□F2 CS-EB10□F3 CS-EB10□F4
	For base piping, A, AJ type manifolds	CS-EB10□A1 CS-EB10□A2 CS-EB10□A3 CS-EB10□A4
Item		
Number of positions		2 positions
Number of ports		2, 3 ports
Valve function		Single solenoid NC, NO

Remark: For the optional specifications and order codes, see p.167.

Port Size

Specification	Port	2(A)	1(P)	3(R)	PR
Single unit	Direct piping	M3×0.5	M3×0.5	M3×0.5	—
	Base piping (with sub-base)	M5×0.8	M5×0.8	M5×0.8	M5×0.8
Manifold	FE type	M3×0.5	M5×0.8	Rc1/8	—
	A type	M5×0.8	Rc1/8	Rc1/8	Collected at 3(R) port
	AJ type	Quick fitting for ϕ 4	Rc1/8	Rc1/8	

Specifications

Basic model	For direct piping, FE type manifold	CS-EB10□F1 CS-EB10□F2 CS-EB10□F3 CS-EB10□F4
	For base piping, A, AJ type manifolds	CS-EB10□A1 CS-EB10□A2 CS-EB10□A3 CS-EB10□A4
Item		
Media		Air
Operation type		Internal pilot type
Flow rate characteristics	Sonic conductance C [dm ³ /(s·bar)]	Base piping (A, AJ types): 0.26
	Effective area S [Cv] mm ²	Direct piping (FE type): 1.3 (0.07)
Port size ^{Note 1}		M3×0.5
Lubrication		Not required
Operating pressure range	MPa [psi.]	0.2~0.7 [29~102]
Proof pressure	MPa [psi.]	1.05 [152]
Response time ^{Note 2} ON/OFF	Standard type	10/20 or below
	Low current type (L)	10/50 or below
	Quick response type (S)	6/7 or below
Maximum operating frequency	Standard type	5
	Low current type (L)	2
	Quick response type (S)	10
Operating temperature range (atmosphere and media)	°C [°F]	5~50 [41~122]
Shock resistance	m/s ² [G]	1373.0 {140} (Axial direction 294.2 {30})
Mounting direction		Any

Notes: 1. For details, see the port size on p.164.

2. Values when air pressure is 0.5MPa [73psi.].

Solenoid Specifications

Item		Rated voltage	DC12V (Standard type)	DC24V (Standard type)	DC24V (Low current type)	DC24V (Quick response type)	
Operating voltage range		V	10.8~13.2 (12±10%)	21.6~26.4 (24±10%)	21.6~26.4 (24±10%)	21.6~26.4 (24±10%)	
Standard type	Current (when rated voltage is applied)	mA (r.m.s)	46	23	—	—	
	Power consumption	W	0.55	0.55	—	—	
Low current type Quick response type	Current (when rated voltage is applied)	Starting	mA	—	23	125	
		Holding	mA	—	—	6.3	46
	Power consumption	Starting	W	—	—	0.55	3
		Holding	W	—	—	0.15	1.1
	Start-up time (standard time)	ms	—	—	200 or below	30 or below	
Allowable leakage current	mA	2	1	0.5	4		
Insulation resistance	MΩ	Over 100 (value at DC500V megger)					
Color of LED indicator		Red					
Surge suppression (as standard)		Flywheel diode					

Operating Principles and Major Parts

2-port

CS-EB10F1
De-energized

CS-EB10F2
De-energized

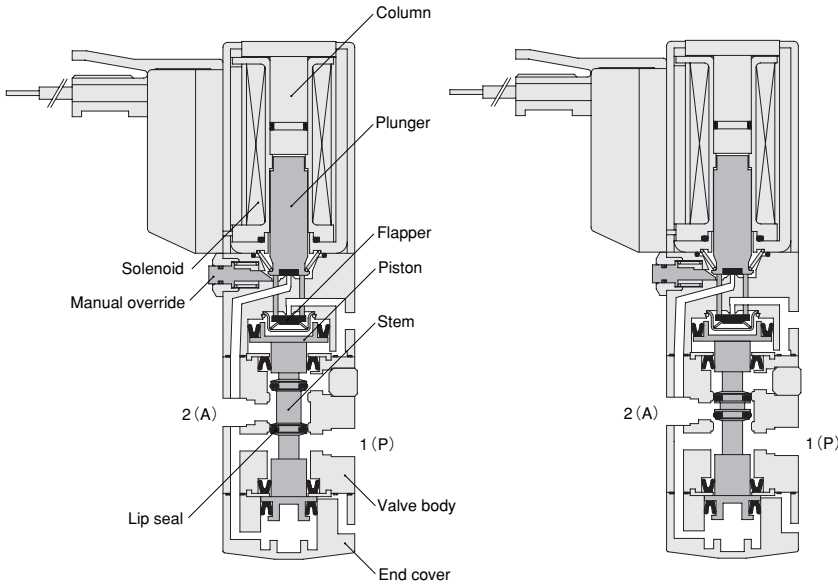

Major Parts and Materials

	Parts	Materials
Valve	Body	Aluminum alloy
	Stem	(anodized)
	Lip seal	Synthetic rubber
	Flapper	
	Mounting base	Mild steel (zinc plated)
	Sub-base	Aluminum alloy (anodized)
	Plunger	Magnetic stainless steel
	Column	Steel
End cover	Plastic	
Manifold	Body	Aluminum alloy (anodized)
	Block-off plate	Mild steel (nickel plated)
	Seal	Synthetic rubber

3-port

CS-EB10F3
De-energized

CS-EB10F4
De-energized

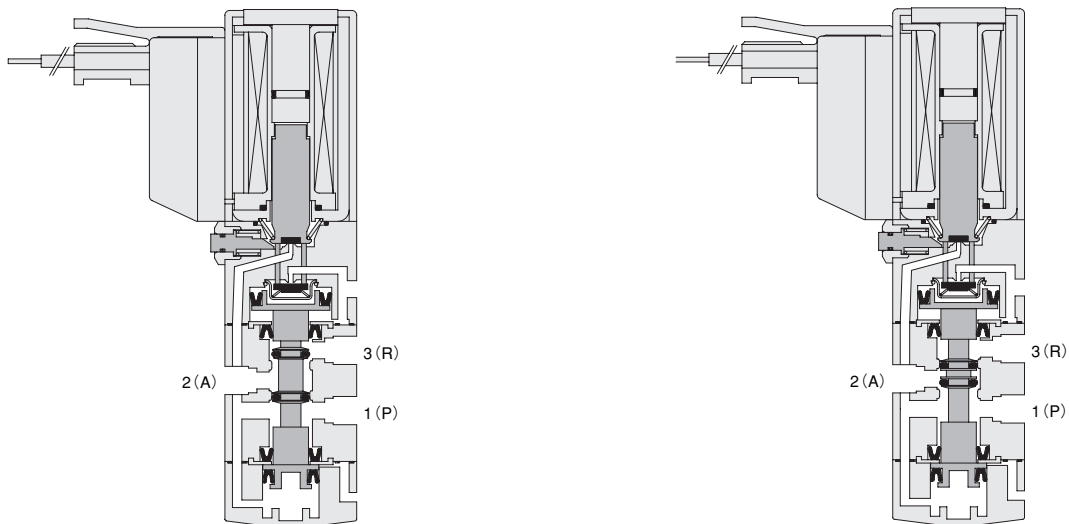

EB Series Single Valve Unit for Manifold/Sub-base Order Codes



Model

CS-EB10

Standard type

CS-EB10L

Low current type

CS-EB10S

Quick response type

Valve specification

F1, A1: 2-port normally closed (NC)

F2, A2: 2-port normally open (NO)

F3, A3: 3-port normally closed (NC)

F4, A4: 3-port normally open (NO)

Sub-base

Without sub-base

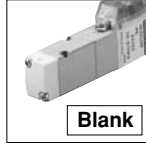

With sub-base



Manual override

Blank: Non-locking type

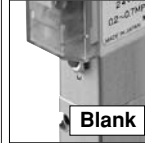

-83: Locking protruding type

Wiring specification

S type plug connector
Lead wire 300mm [11.8in.]



L type plug connector
Lead wire 300mm [11.8in.]

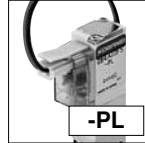

S type plug connector
Lead wire 1000mm [39in.]



L type plug connector
Lead wire 1000mm [39in.]



S type plug connector
Lead wire 3000mm [118in.]

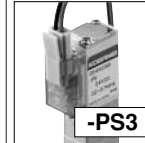

L type plug connector
Lead wire 3000mm [118in.]



S type plug connector
Without connector ass'y



L type plug connector
Without connector ass'y



Grommet type^{Note2}
Lead wire 300mm [11.8in.]
(moisture proof specification)



Voltage

-D4

DC24V

-D5

DC12V^{Note3}

	Model	Valve specification	Sub-base	Manual override	Wiring specification	Voltage
--	-------	---------------------	----------	-----------------	----------------------	---------

Direct piping	CS-EB10 CS-EB10L CS-EB10S	F1 F2	Blank -25	Blank -83 ^{Note1}	-PS -PS1 -PS3 -PSN -PL -PL1 -PL3 -PLN -GL ^{Note2}	-D4 -D5 ^{Note3}
		F3 F4				
Base piping	CS-EB10 CS-EB10L CS-EB10S	A1 A2 A3 A4	Blank -25	Blank -83 ^{Note1}	-PS -PS1 -PS3 -PSN -PL -PL1 -PL3 -PLN -GL ^{Note2}	-D4 -D5 ^{Note3}

Notes: 1. The locking protruding type manual override is not available in the quick response type **CS-EB10S**.

2. The grommet type is not available in the low current type **CS-EB10L** and quick response type **CS-EB10S**.

3. The DC12V specification is not available in the low current type **CS-EB10L** and quick response type **CS-EB10S**.

EB Series Additional Parts Order Codes

Block-off plate (block-off plate, gasket, and 2 mounting screws)

CS-EBBP -

Specification
FE : For FE type manifold
A : For A, AJ type manifolds

Connector-related

EAZ -

Connector specification
P : Connector, lead wire length 300mm [11.8in.]
P1 : Connector, lead wire length 1000mm [39in.]
P3 : Connector, lead wire length 3000mm [118in.]
PN : Connector, without lead wire (contacts included)

Common connector assembly

EAZ -

Connector specification
PA : Positive common A type, connector, lead wire length 300mm [11.8in.]
PA1 : Positive common A type, connector, lead wire length 1000mm [39in.]
PA3 : Positive common A type, connector, lead wire length 3000mm [118in.]
PB : Positive common B type, connector, lead wire length 300mm [11.8in.]
PB1 : Positive common B type, connector, lead wire length 1000mm [39in.]
PB3 : Positive common B type, connector, lead wire length 3000mm [118in.]
PC : Positive common C type, connector, lead wire length 300mm [11.8in.]
PC1 : Positive common C type, connector, lead wire length 1000mm [39in.]
PC3 : Positive common C type, connector, lead wire length 3000mm [118in.]
CPN : Positive common, connector, without lead wire (short bar and contacts included)

A type: EAZ-PA*



B type: EAZ-PB*

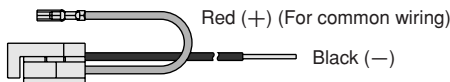

C type: EAZ-PC*

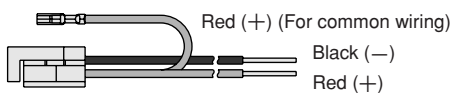

*Lead wire length
Blank : 300mm [11.8in.]
1 : 1000mm [39in.]
3 : 3000mm [118in.]

Application example

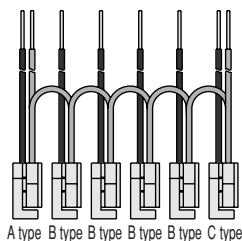

Dimensions of EB Series Solenoid Valve mm [in.]

2, 3-port, single solenoid (with sub-base)

CS-EB10 □ A1-25-PL

CS-EB10 □ A2-25-PL

CS-EB10 □ A3-25-PL

CS-EB10 □ A4-25-PL

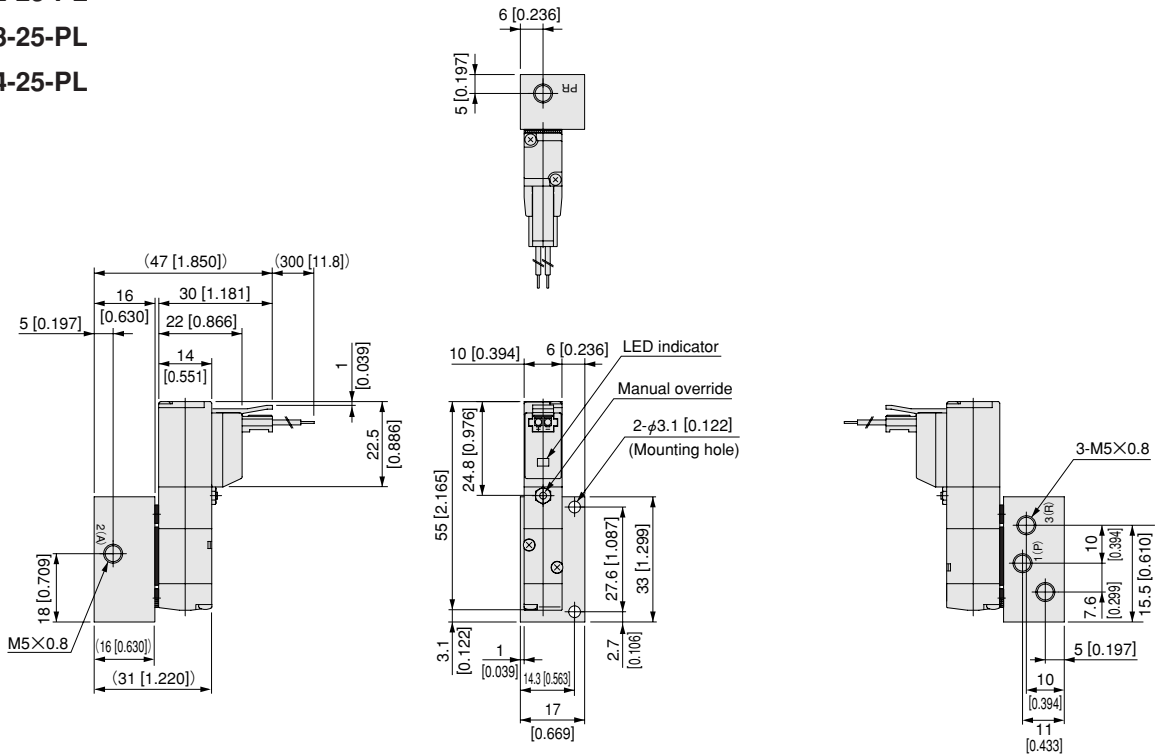

Options

● Locking protruding type manual override: **-83**

● Grommet: **-GL**

● S type plug connector: **-PS**

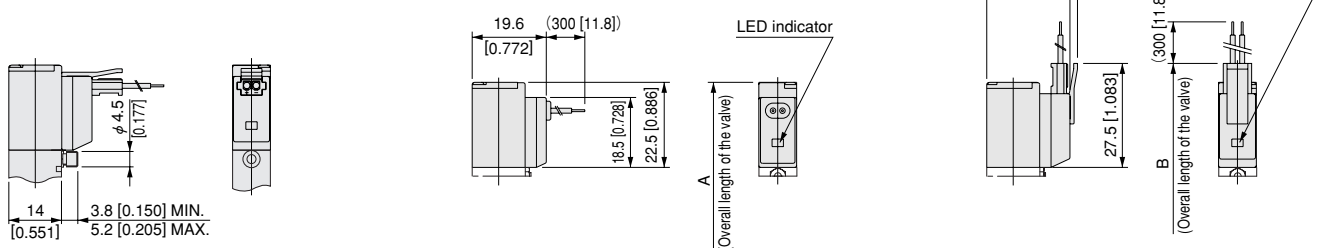

Model	Code	A	B	Remark
CS-EB10F1 ~ CS-EB10F4, CS-EB10A1 ~ CS-EB10A4		55 [2.165]	60 [2.362]	Overall length to the end of the valve
CS-EB10LF1 ~ CS-EB10LF4, CS-EB10LA1 ~ CS-EB10LA4		—	60 [2.362]	
CS-EB10SF1 ~ CS-EB10SF4, CS-EB10SA1 ~ CS-EB10SA4		—	60 [2.362]	

Dimensions of EB Series Manifold mm [in.]

For 2, 3-port

CS-EBM□FE

(Direct piping type)

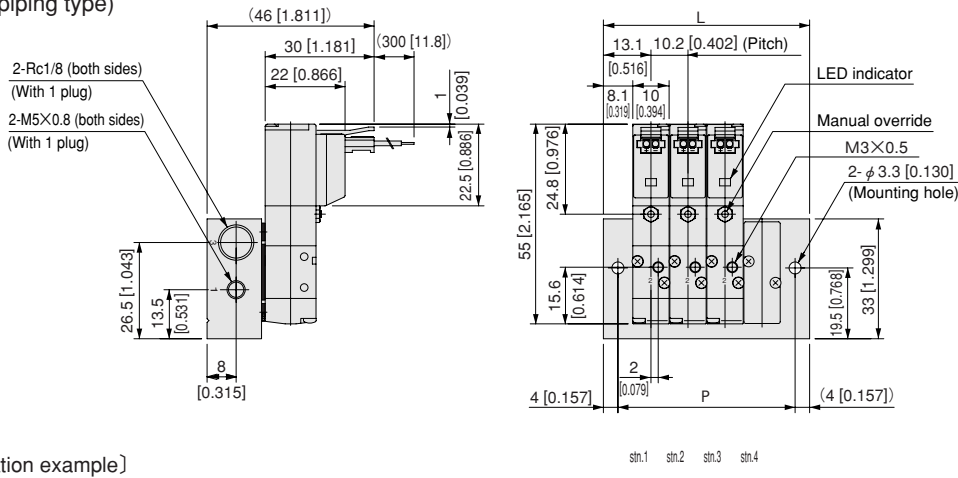

(Installation example)

CS-EBM4FE

- stn.1 CS-EB10F1-PL-D4
- stn.2 CS-EB10F3-PL-D4
- stn.3 CS-EB10F4-PL-D4
- stn.4 CS-EBBP-F

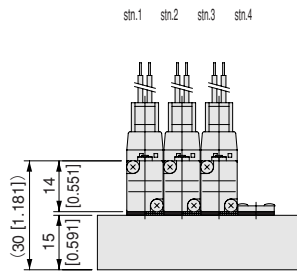

CS-EBM□A

(Base piping type)

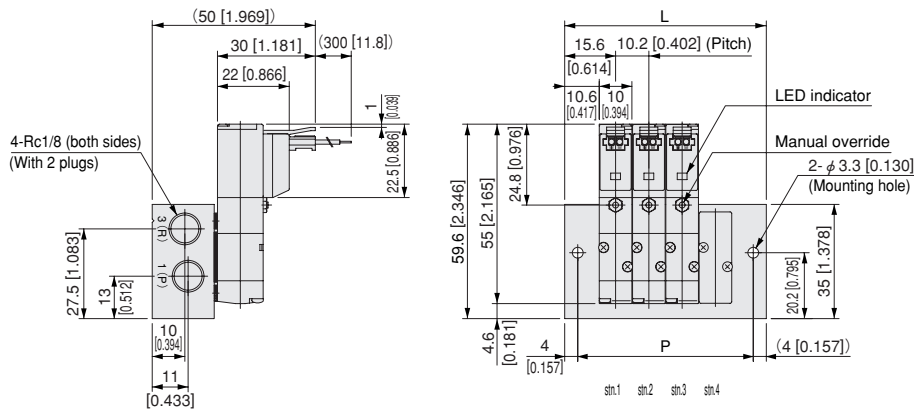

(Installation example)

CS-EBM4A

- stn.1 CS-EB10A1-PL-D4
- stn.2 CS-EB10A3-PL-D4
- stn.3 CS-EB10A4-PL-D4
- stn.4 CS-EBBP-A

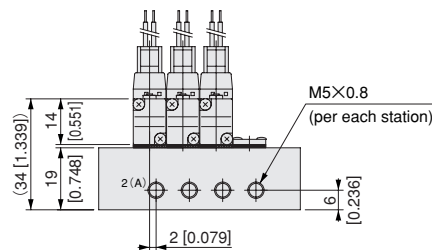

Unit dimensions

No. of units	L	P
2	36.4 [1.433]	28.4 [1.118]
3	46.6 [1.835]	38.6 [1.520]
4	56.8 [2.236]	48.8 [1.921]
5	67.0 [2.638]	59.0 [2.323]
6	77.2 [3.039]	69.2 [2.724]
7	87.4 [3.441]	79.4 [3.126]
8	97.6 [3.843]	89.6 [3.528]
9	107.8 [4.244]	99.8 [3.929]
10	118.0 [4.646]	110.0 [4.331]
11	128.2 [5.047]	120.2 [4.732]
12	138.4 [5.449]	130.4 [5.134]
13	148.6 [5.850]	140.6 [5.535]
14	158.8 [6.252]	150.8 [5.937]
15	169.0 [6.654]	161.0 [6.339]
16	179.2 [7.055]	171.2 [6.740]
17	189.4 [7.457]	181.4 [7.142]
18	199.6 [7.858]	191.6 [7.543]
19	209.8 [8.260]	201.8 [7.945]
20	220.0 [8.661]	212.0 [8.346]

Unit dimensions

No. of units	L	P
2	41.4 [1.630]	33.4 [1.315]
3	51.6 [2.031]	43.6 [1.717]
4	61.8 [2.433]	53.8 [2.118]
5	72.0 [2.835]	64.0 [2.520]
6	82.2 [3.236]	74.2 [2.921]
7	92.4 [3.638]	84.4 [3.323]
8	102.6 [4.039]	94.6 [3.724]
9	112.8 [4.441]	104.8 [4.126]
10	123.0 [4.843]	115.0 [4.528]
11	133.2 [5.244]	125.2 [4.929]
12	143.4 [5.646]	135.4 [5.331]
13	153.6 [6.047]	145.6 [5.732]
14	163.8 [6.449]	155.8 [6.134]
15	174.0 [6.850]	166.0 [6.535]
16	184.2 [7.252]	176.2 [6.937]
17	194.4 [7.654]	186.4 [7.339]
18	204.6 [8.055]	196.6 [7.740]
19	214.8 [8.457]	206.8 [8.142]
20	225.0 [8.858]	217.0 [8.543]

Dimensions of EB Series Manifold mm [in.]

For 2, 3-port

CS-EBM□AJ

(Base piping type with quick fittings)

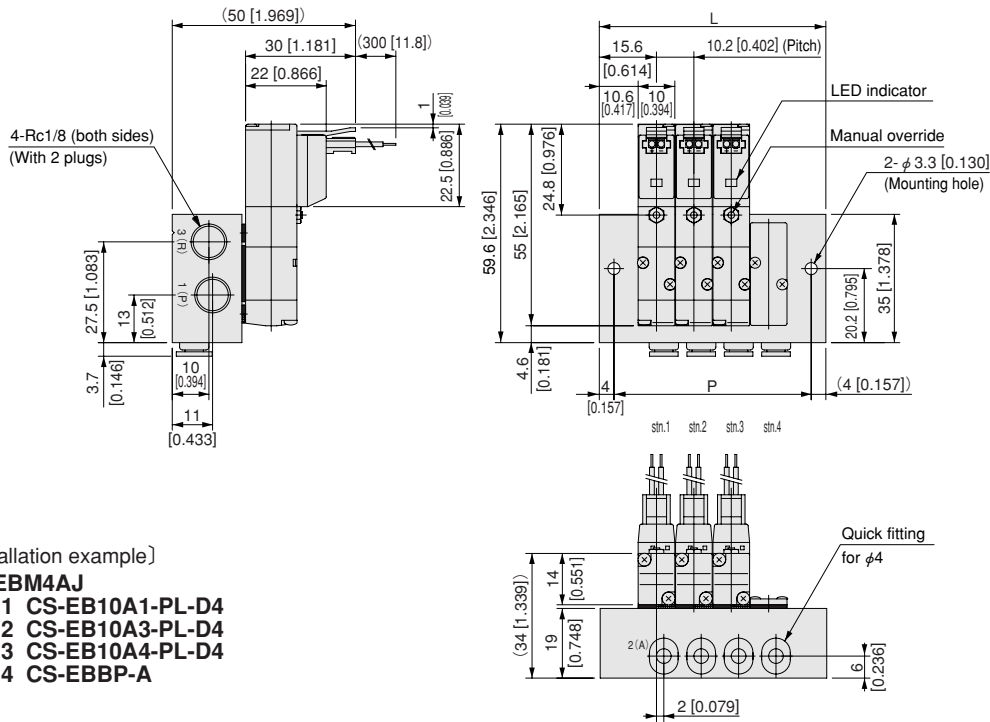

[Installation example]

CS-EBM4AJ

- stn.1 CS-EB10A1-PL-D4
- stn.2 CS-EB10A3-PL-D4
- stn.3 CS-EB10A4-PL-D4
- stn.4 CS-EBBP-A

Unit dimensions

No. of units	L	P
2	41.4 [1.630]	33.4 [1.315]
3	51.6 [2.031]	43.6 [1.717]
4	61.8 [2.433]	53.8 [2.118]
5	72.0 [2.835]	64.0 [2.520]
6	82.2 [3.236]	74.2 [2.921]
7	92.4 [3.638]	84.4 [3.323]
8	102.6 [4.039]	94.6 [3.724]
9	112.8 [4.441]	104.8 [4.126]
10	123.0 [4.843]	115.0 [4.528]
11	133.2 [5.244]	125.2 [4.929]
12	143.4 [5.646]	135.4 [5.331]
13	153.6 [6.047]	145.6 [5.732]
14	163.8 [6.449]	155.8 [6.134]
15	174.0 [6.850]	166.0 [6.535]
16	184.2 [7.252]	176.2 [6.937]
17	194.4 [7.654]	186.4 [7.339]
18	204.6 [8.055]	196.6 [7.740]
19	214.8 [8.457]	206.8 [8.142]
20	225.0 [8.858]	217.0 [8.543]