

**Symbol**

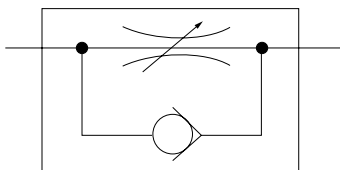

**Specifications**

Type	Standard type	Mini type	Union straight type	Large flow type
Mounting type	Direct mounting on cylinder		-----	Direct mounting on cylinder
Media	Air (Cannot be used in vacuum systems)			
Operating pressure range	0~0.9MPa [0~131psi.]			
Operating temperature range	5~60°C [41~140°F]			
Recommended tube	Nylon tube, urethane tube			
Sales unit	1 pc.			

Cautions: The tube outer diameter accuracy should be, for nylon tubes, within  $\pm 0.1\text{mm}$  [ $\pm 0.004\text{in.}$ ] of the nominal dimensions, and for urethane tubes, within  $\pm 0.15\text{mm}$  [ $\pm 0.006\text{in.}$ ] of the nominal dimensions, while the ovalness (difference between long diameter and short diameter) should be within 0.2mm [0.008in.].

**● Cracking pressure**

Mounting thread size	Cracking pressure MPa [psi.]
M5	0.1 [15]
01	0.1 [15]
02	0.06 [9]
03	0.07 [10]
04	0.08 [12]

Tube size	Cracking pressure MPa [psi.]
$\phi 4$	0.1 [15]
$\phi 6$	0.1 [15]
$\phi 8$	0.06 [9]
$\phi 10$	0.06 [9]
$\phi 12$	0.06 [9]

Mounting thread size	Cracking pressure MPa [psi.]
M3	0.1 [15]
M5	0.1 [15]
01	0.1 [15]
02	0.06 [9]

Mounting thread size	Cracking pressure MPa [psi.]
01	0.07 [10]
02	0.05 [7]
03	0.05 [7]
04	0.05 [7]

**Inner Construction, Major Parts and Materials**

- Standard type
- Large flow type
- Mini type

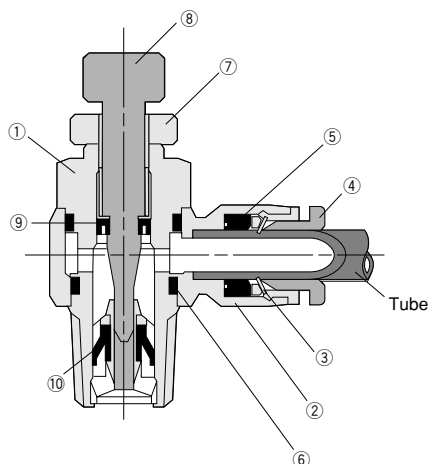

No.	Parts	Materials
①	Metal body	Brass (nickel plated <sup>Note</sup> )
②	Plastic body	Polybutylene terephthalate
③	Lock claw	Stainless steel
④	Release ring	Polyacetal
⑤	Elastic sleeve	Synthetic rubber (NBR)
⑥	O-ring	Synthetic rubber (NBR)
⑦	Lock nut	Aluminum
⑧	Needle	Brass
⑨	V-seal	Synthetic rubber (NBR)
⑩	Diaphragm	

Note: For Mini type only

# Order Codes

## ● Standard type

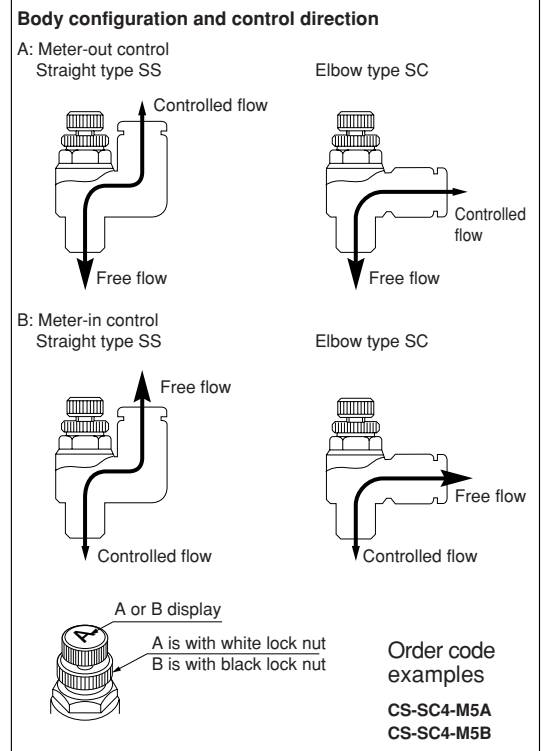
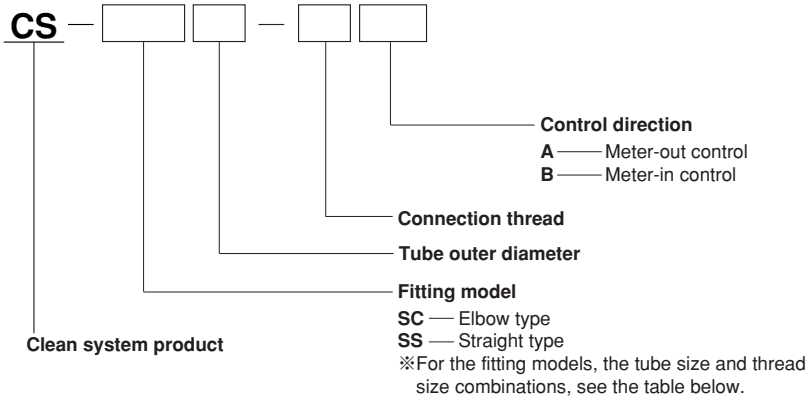

## ● SC: Elbow



Tube size mm	Thread size				
	M5×0.8	R1/8	R1/4	R3/8	R1/2
4	M5	01	—	—	—
6	M5	01	02	03	—
8	—	01	02	03	04
10	—	—	02	03	04
12	—	—	—	03	04

## ● SS: Straight



Tube size mm	Thread size				
	M5×0.8	R1/8	R1/4	R3/8	R1/2
4	M5	01	—	—	—
6	M5	01	02	—	—
8	—	01	02	03	—
10	—	—	02	03	—
12	—	—	—	03	04

Note: For details of the dimensions, see the General Catalog of Air Treatment, Auxiliary, Vacuum.

# Order Codes

## ●Mini type

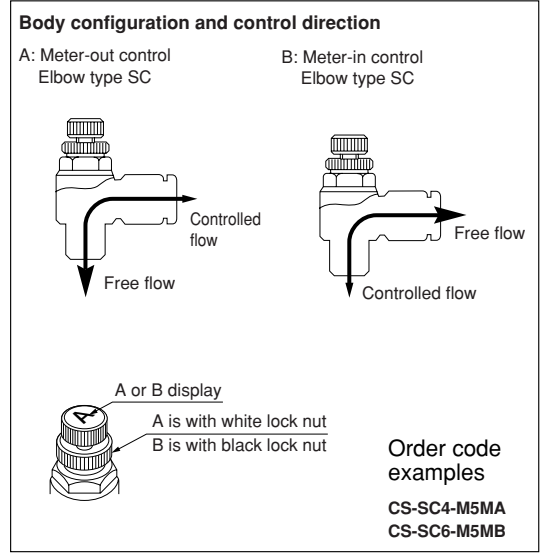
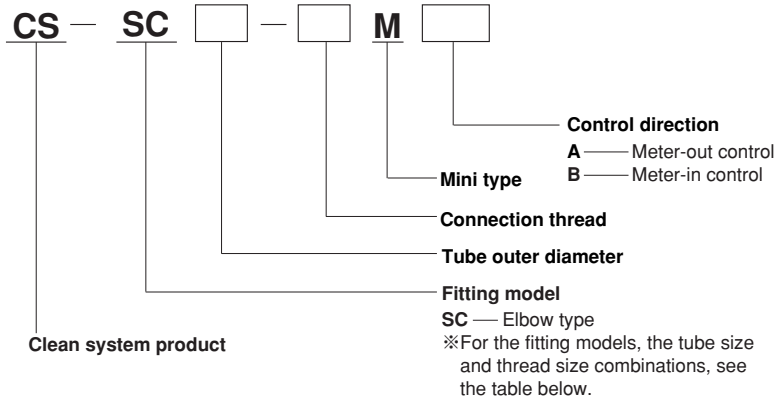

## ●SC: Elbow



Tube size mm	Thread size			
	M3×0.5	M5×0.8	R1/8	R1/4
3	M3	M5	—	—
4	M3	M5	01	—
6	—	M5	01	02

Note: For details of the dimensions, see the General Catalog of Air Treatment, Auxiliary, Vacuum.

## ●Union straight type

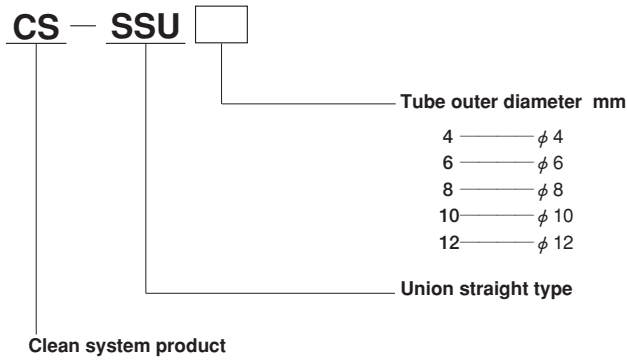

- Notes: 1. For the union straight type, no order code is available for control direction.  
To determine the mounting direction, check the speed controller's symbol mark on the side of the body.
2. For details of the dimensions, see the General Catalog of Air Treatment, Auxiliary, Vacuum.

# Order Codes

## ● Large flow type

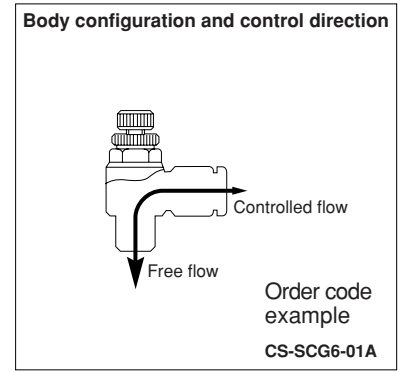
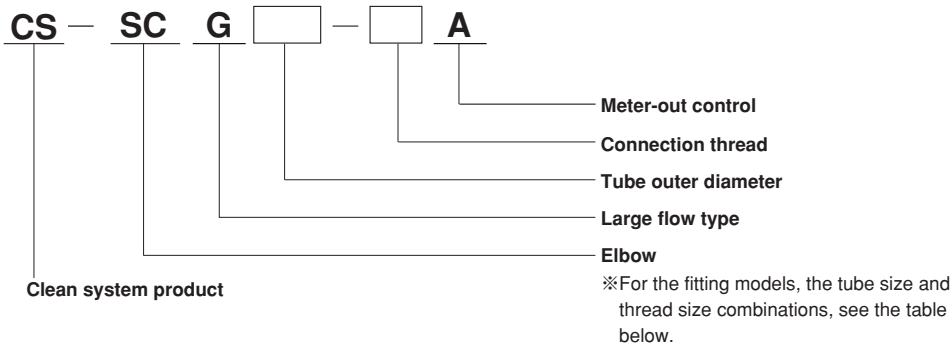

**Caution:** The large flow type can be identified by the AG mark on the needle head, and by the blue lock nut.

## ● SC: Elbow



Tube size mm	Thread size			
	R1/8	R1/4	R3/8	R1/2
6	01	02	—	—
8	01	02	03	—
10	—	02	03	—
12	—	—	03	04

Note: For details of the dimensions, see the General Catalog of Air Treatment, Auxiliary, Vacuum.



# Koganei Clean System products provide complete support for the maintenance of a clean environment inside the cleanroom.

Koganei Clean System products meet the needs of the ultra-clean production environment. In everything from actuators and valves to air preparation and auxiliary equipment, anti-corrosion materials processing and other Koganei-developed design concepts serve to prevent particle contamination within the cleanroom. These perfectly designed mechanisms, which resolve even the slightest leaks to the outside during operations, have already won a high level of reliability.

## Koganei Cleanliness

There is currently no standard in JIS or elsewhere for methods of evaluating cleanliness for pneumatic equipment in the cleanroom specifications. Therefore, to measure the effects of cleanroom contamination by pneumatic equipment, Koganei has decided to use “number of particles generated per 10 operations,” rather than particle density. Koganei has also developed classifications for application classes in cleanroom, based on JIS and other upper limit density tables, and on the company’s own experience.

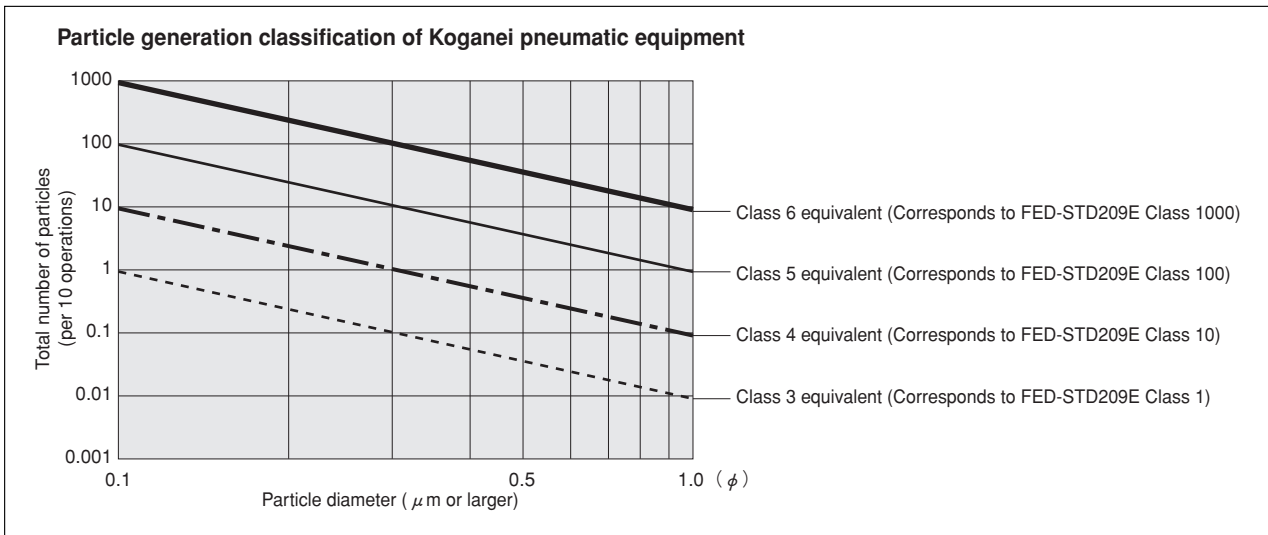

- Remarks:
1. In the above table, product performance in terms of the number of particles generated per 10 operations is expressed as the upper limit of particles corresponding to the equivalent JIS or ISO class.
  2. In the above table, values in the JIS, ISO, and FED-STD upper limit density tables are calculated as upper density per liter.
  3. The classes shown are clean levels as classified in JIS and ISO.

From the above definitions, the Koganei clean level classes can be viewed as the level of average contamination per liter of surrounding air over a period of 10 operations in cleanroom. Air ventilation in cleanrooms is usually faster than 1 cycle per minute, and clean volumetric capacity is usually larger than 1 liter, which should provide a sufficient safety margin in practice.

Caution: The above conclusions are based on an ideal situation in which air ventilation is being implemented. For specific cases where air ventilation is not ensured, caution is needed since the clean classes cannot be maintained.

**The clean system diagrams shown here are for Class 5 equivalent products. For Class 4 or Class 3 equivalent products, consult us.**

# Evaluations of Cleanliness

Koganei has therefore specified its in-house measurement methods, to conduct evaluations on the cleanroom rating.

The number of particles of the Air Cylinder Cleanroom Specification is measured as shown in the method below.

## 1. Measurement conditions

1-1 Test circuit: Figure 1 (no suction), Figure 2 (with suction)

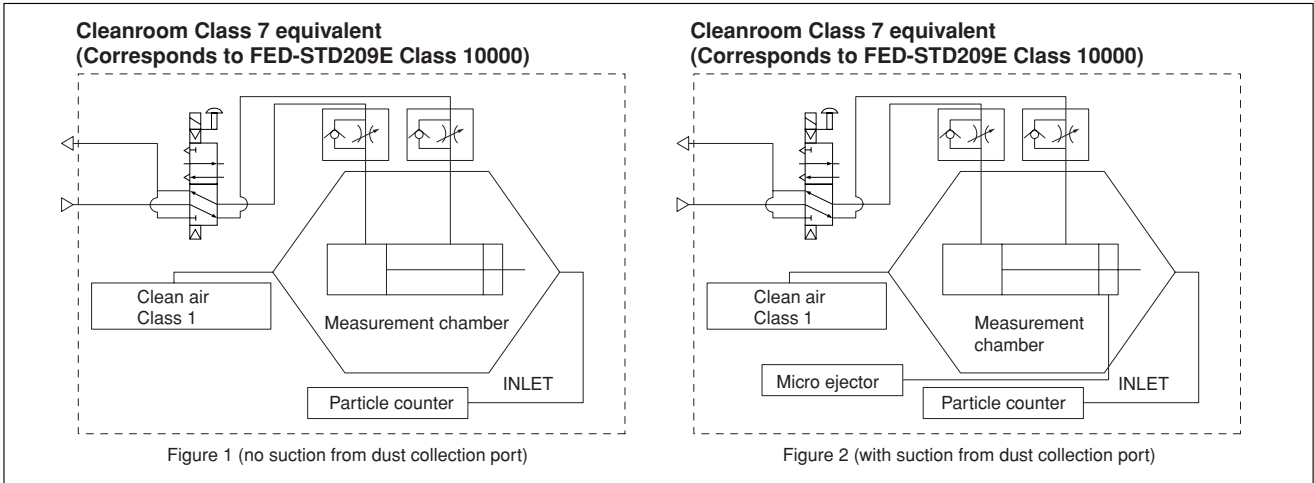

1-2 Operating conditions of tested cylinder

- Operating frequency: 1Hz
- Average speed: 500mm/s [20in./sec.]
- Applied pressure: 0.5MPa [73psi.]
- Suction condition: Microejector ME05, Primary side: 0.5MPa [73psi.] applied, Tube:  $\phi 6$  [0.236in.]
- Mounting direction: Vertical
- Chamber volume: 8.3  $\ell$  [0.293ft.<sup>3</sup>]

## 2. Particle counter

- Manufacturer/model: RION/KM20
- Suction flow rate: 28.3  $\ell$  /min [1ft.<sup>3</sup>/min.]
- Particle diameter: 0.1  $\mu\text{m}$ , 0.2  $\mu\text{m}$ , 0.3  $\mu\text{m}$ , 0.5  $\mu\text{m}$ , 0.7  $\mu\text{m}$ , 1.0  $\mu\text{m}$

## 3. Measurement method

- 3-1 Confirmation of number of particles in the measurement system  
Under the conditions in the above 1 and 2, using a particle counter to measure the sample for 9 minutes without operating the measurement sample, and confirmed the measured number of particle is 1 piece or less.
- 3-2 Measurement under operation  
Under the conditions in the above 1 and 2, operating the measurement sample for 36 minutes, and measured the total values in the latter half of 18 minutes test.
- 3-3 Reconfirmation  
Performed the measurement in 3-1 again, to reconfirm the number of particles in the measurement system.

## 4. Measurement results

### ● Cleanroom specification

Jig Cylinder (no suction from dust collection port)

Particle generation over 1 million operations (CS-CDA16 $\times$ 30)

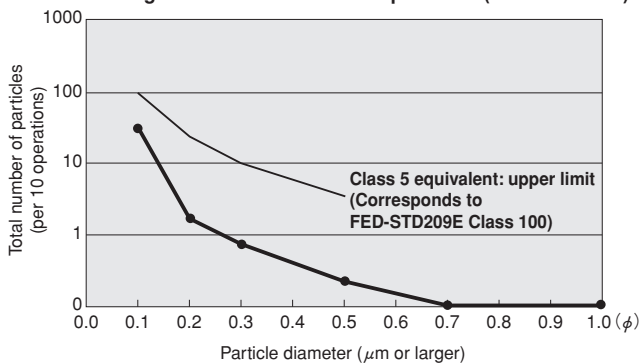

### ● Cleanroom specification

Slim Cylinder (with suction from dust collection port)

Particle generation over 1 million operations (CS-DA20 $\times$ 100)

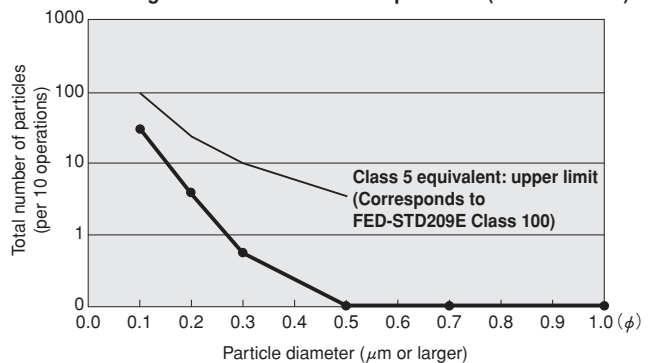

For “safety precautions” listed in the Clean System Product Drawings, see the materials below.

- For actuators, see “Safety Precautions” on p. 45 of the Actuators General Catalog .
- For valves, see “Safety Precautions” on p. 31 of the Valves General Catalog.
- For air treatment and auxiliary equipment, see “Safety Precautions” on p.31 of the General Catalog of Air Treatment, Auxiliary, Vacuum.

**Symbol**

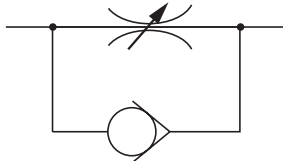

**Specifications**

Item		Model	CS-TSCO	CS-TSCO-L	CS-TSCO-UC	CS-TSCO-UL
Piping type	Controlled flow P		Female thread		Universal male thread	
	Controlled flow A		Female thread			
Port size			M3×0.5			
Media			Air			
Operating pressure range	MPa [psi.]		0~0.7 [0~102]			
Proof pressure	MPa [psi.]		1.03 [149]			
Cracking pressure	MPa [psi.]		0.05 [7]			
Operating temperature range	°C [°F]		5~60 [41~140]			
Mass	g [oz.]		5 [0.18]	4 [0.14]	6 [0.21]	6 [0.21]

**Inner Construction and Major Parts**

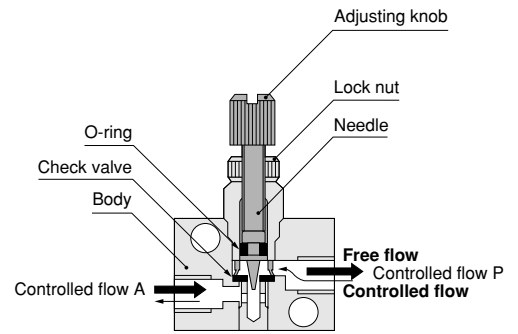

**Flow Rate Characteristics**

● **Controlled flow**

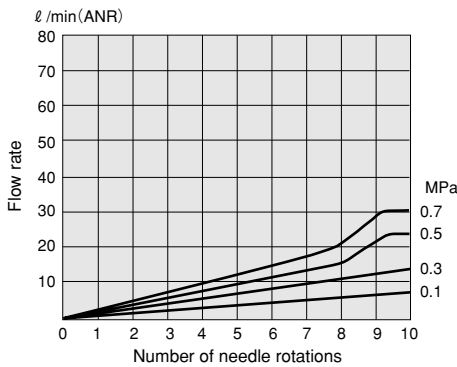

● **Free flow**

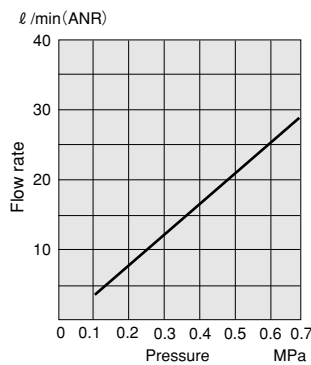

1MPa = 145psi. 1 l/min = 0.0353ft<sup>3</sup>/min.

**Major Parts and Materials**

Parts	Materials
Body	Brass (nickel electroplated)
Needle	Stainless steel
Lock nut	Brass (nickel electroplated)
Check valve	Synthetic rubber (NBR)
O-ring	
Adjusting knob	Brass (nickel electroplated)

**Dimensions mm [in.]**

● **CS-TSCO**

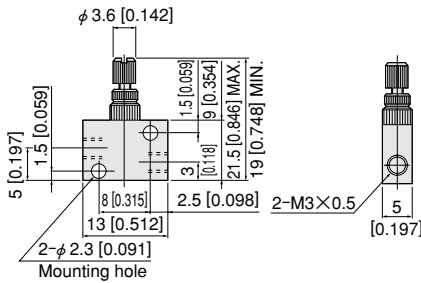

● **CS-TSCO-L**

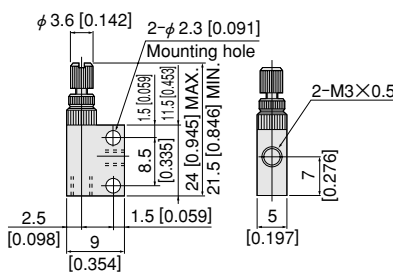

● **CS-TSCO-UC**

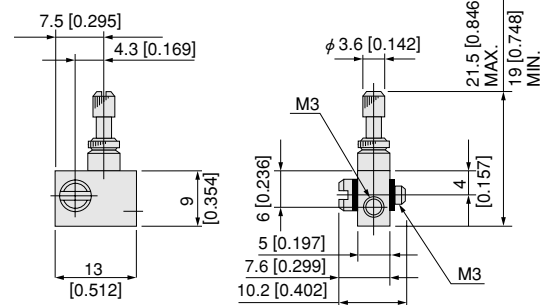

● **CS-TSCO-UL**

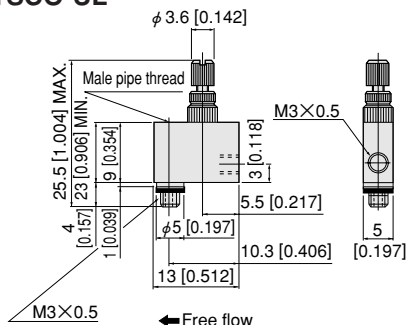

**Handling Instructions and Precautions**

- Always use fingertips to rotate and tighten the lock nut and needle. Use of excessive tightening force with tools, etc., could cause damage to the parts.
- When using a universal male thread type, secure by tightening the male pipe thread for piping. The tightening torque should be 0.5N·m [4.4in·lbf] or less.



# Koganei Clean System products provide complete support for the maintenance of a clean environment inside the cleanroom.

Koganei Clean System products meet the needs of the ultra-clean production environment. In everything from actuators and valves to air preparation and auxiliary equipment, anti-corrosion materials processing and other Koganei-developed design concepts serve to prevent particle contamination within the cleanroom. These perfectly designed mechanisms, which resolve even the slightest leaks to the outside during operations, have already won a high level of reliability.

## Koganei Cleanliness

There is currently no standard in JIS or elsewhere for methods of evaluating cleanliness for pneumatic equipment in the cleanroom specifications. Therefore, to measure the effects of cleanroom contamination by pneumatic equipment, Koganei has decided to use “number of particles generated per 10 operations,” rather than particle density. Koganei has also developed classifications for application classes in cleanroom, based on JIS and other upper limit density tables, and on the company’s own experience.

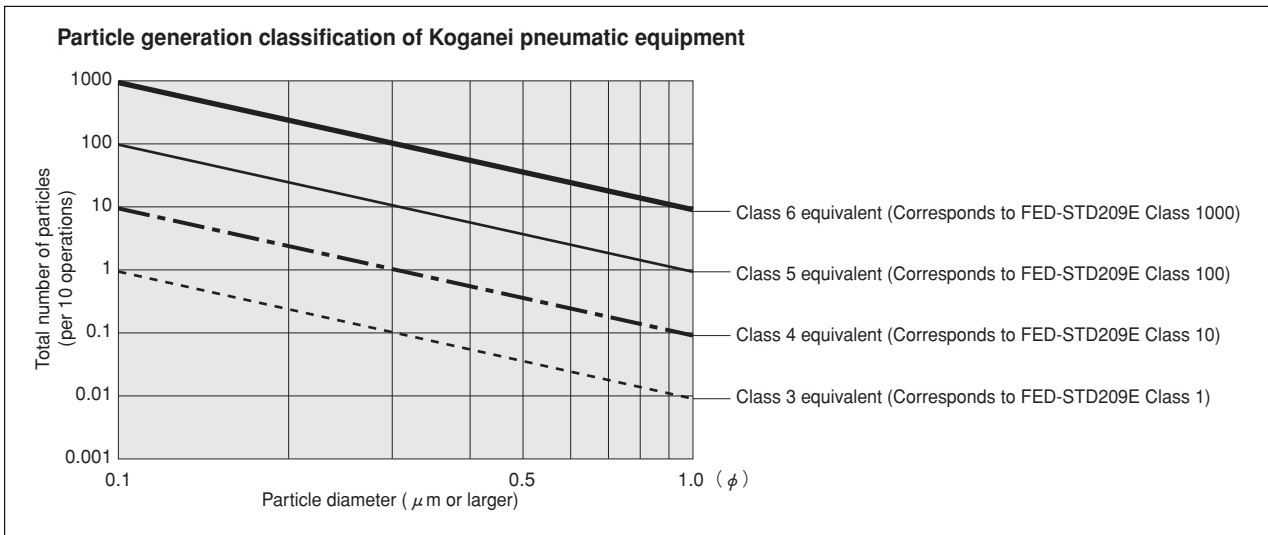

- Remarks:
1. In the above table, product performance in terms of the number of particles generated per 10 operations is expressed as the upper limit of particles corresponding to the equivalent JIS or ISO class.
  2. In the above table, values in the JIS, ISO, and FED-STD upper limit density tables are calculated as upper density per liter.
  3. The classes shown are clean levels as classified in JIS and ISO.

From the above definitions, the Koganei clean level classes can be viewed as the level of average contamination per liter of surrounding air over a period of 10 operations in cleanroom. Air ventilation in cleanrooms is usually faster than 1 cycle per minute, and clean volumetric capacity is usually larger than 1 liter, which should provide a sufficient safety margin in practice.

Caution: The above conclusions are based on an ideal situation in which air ventilation is being implemented. For specific cases where air ventilation is not ensured, caution is needed since the clean classes cannot be maintained.

**The clean system diagrams shown here are for Class 5 equivalent products. For Class 4 or Class 3 equivalent products, consult us.**

# Evaluations of Cleanliness

Koganei has therefore specified its in-house measurement methods, to conduct evaluations on the cleanroom rating.

The number of particles of the Air Cylinder Cleanroom Specification is measured as shown in the method below.

## 1. Measurement conditions

1-1 Test circuit: Figure 1 (no suction), Figure 2 (with suction)

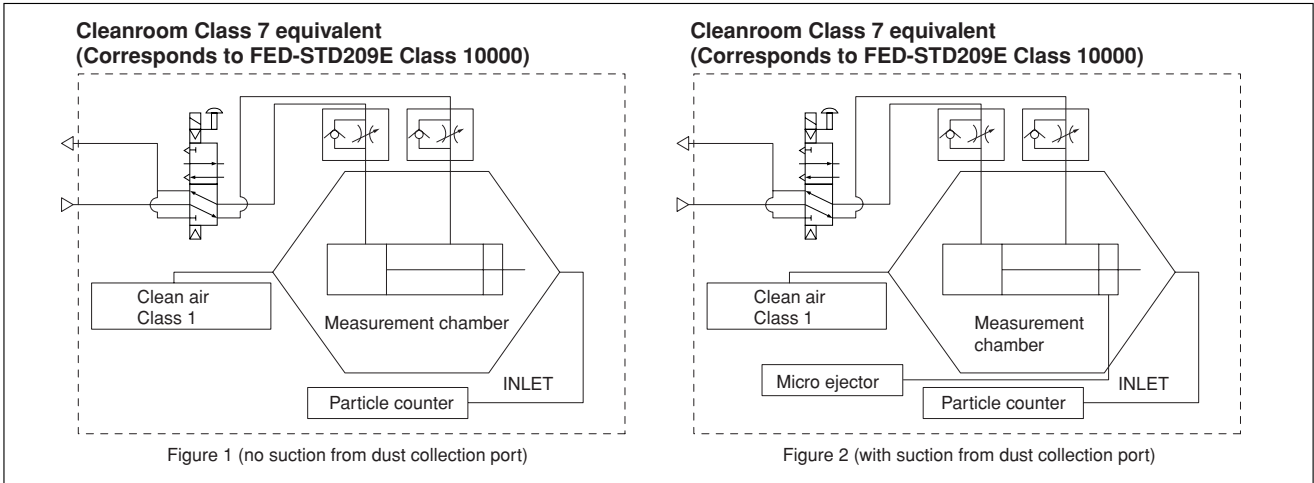

### 1-2 Operating conditions of tested cylinder

- Operating frequency: 1Hz
- Average speed: 500mm/s [20in./sec.]
- Applied pressure: 0.5MPa [73psi.]
- Suction condition: Microejector ME05, Primary side: 0.5MPa [73psi.] applied, Tube:  $\phi 6$  [0.236in.]
- Mounting direction: Vertical
- Chamber volume: 8.3  $\ell$  [0.293ft.<sup>3</sup>]

## 2. Particle counter

- Manufacturer/model: RION/KM20
- Suction flow rate: 28.3  $\ell$  /min [1ft.<sup>3</sup>/min.]
- Particle diameter: 0.1  $\mu\text{m}$ , 0.2  $\mu\text{m}$ , 0.3  $\mu\text{m}$ , 0.5  $\mu\text{m}$ , 0.7  $\mu\text{m}$ , 1.0  $\mu\text{m}$

## 3. Measurement method

- 3-1 Confirmation of number of particles in the measurement system  
Under the conditions in the above 1 and 2, using a particle counter to measure the sample for 9 minutes without operating the measurement sample, and confirmed the measured number of particle is 1 piece or less.
- 3-2 Measurement under operation  
Under the conditions in the above 1 and 2, operating the measurement sample for 36 minutes, and measured the total values in the latter half of 18 minutes test.
- 3-3 Reconfirmation  
Performed the measurement in 3-1 again, to reconfirm the number of particles in the measurement system.

## 4. Measurement results

### ● Cleanroom specification

Jig Cylinder (no suction from dust collection port)

Particle generation over 1 million operations (CS-CDA16 $\times$ 30)

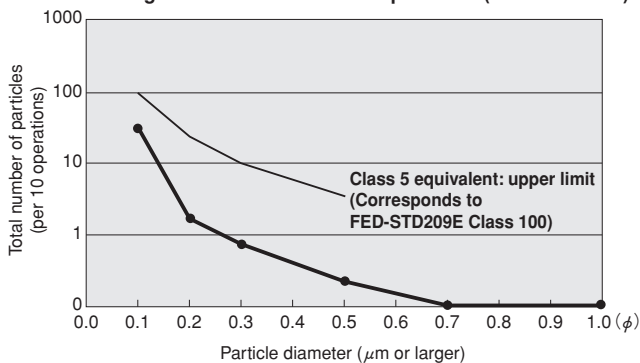

### ● Cleanroom specification

Slim Cylinder (with suction from dust collection port)

Particle generation over 1 million operations (CS-DA20 $\times$ 100)

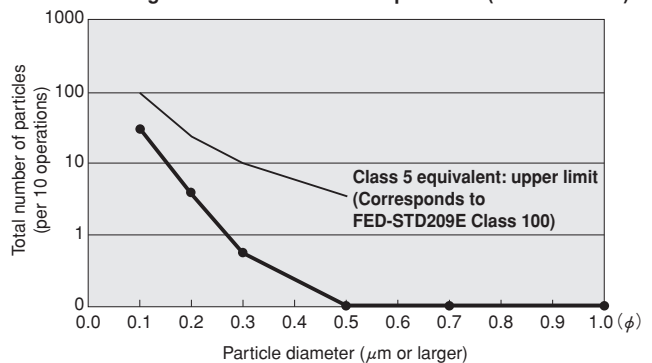

For “safety precautions” listed in the Clean System Product Drawings, see the materials below.

- For actuators, see “Safety Precautions” on p. 45 of the Actuators General Catalog .
- For valves, see “Safety Precautions” on p. 31 of the Valves General Catalog.
- For air treatment and auxiliary equipment, see “Safety Precautions” on p.31 of the General Catalog of Air Treatment, Auxiliary, Vacuum.

**Symbol**

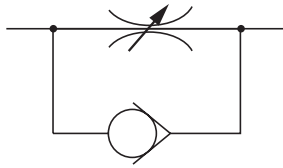

**Specifications**

Item	Model	CS-TSC	CS-TSC-F	CS-TSC-F-BF	CS-TSC-US	CS-TSC-US-BF	CS-TSC-L	CS-TSC-L-BF
Piping type and port size	Controlled flow P	Female thread M5×0.8	Male thread M5×0.8		Union male thread M5×0.8		Male thread M5×0.8	
	Controlled flow A	Female thread M5×0.8		For urethane tube φ4×2.5 Clamp fitting	Female thread M5×0.8	For urethane tube φ4×2.5 Clamp fitting	Female thread M5×0.8	For urethane tube φ4×2.5 Clamp fitting
Media		Air						
Operating pressure range	MPa [psi.]	0~0.9 [0~131]						
Proof pressure	MPa [psi.]	1.32 [191]						
Cracking pressure	MPa [psi.]	0.05 [7]						
Operating temperature range	°C [°F]	5~60 [41~140]						
Mass	g [oz.]	16 [0.56]	18 [0.63]	20.5 [0.72]	19 [0.67]	21.5 [0.76]	15 [0.53]	17 [0.60]

**Major Parts and Materials**

Parts	Materials
Body	Brass (nickel electroplated)
Needle	Stainless steel
Lock nut	Brass (nickel electroplated)
Check valve	Synthetic rubber (NBR)
O-ring	
Adjusting knob	Brass (nickel electroplated)

**Inner Construction and Major Parts**

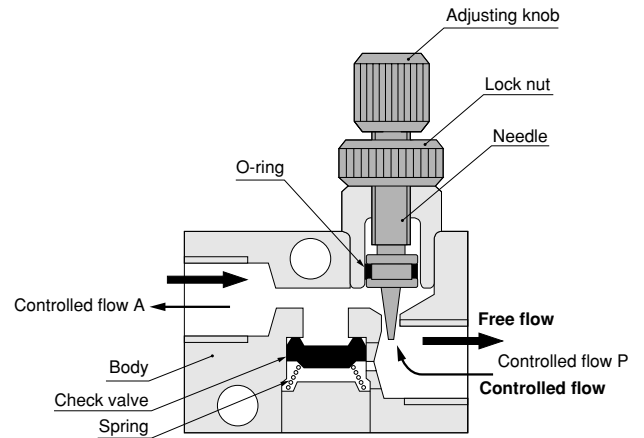

● Straight type

● CS-TSC

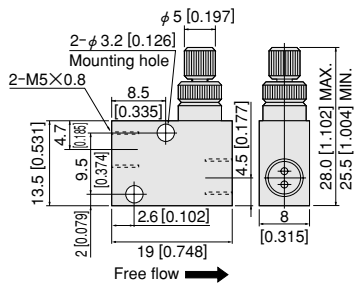

● CS-TSC-F

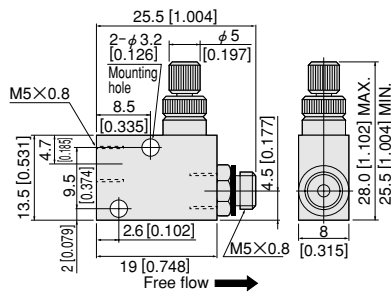

● CS-TSC-F-BF

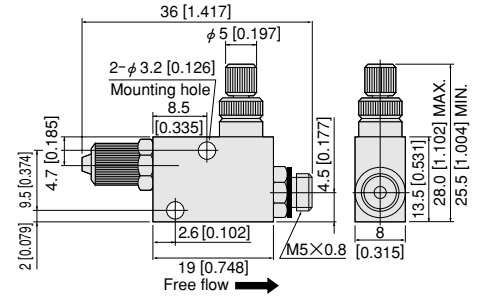

● CS-TSC-US

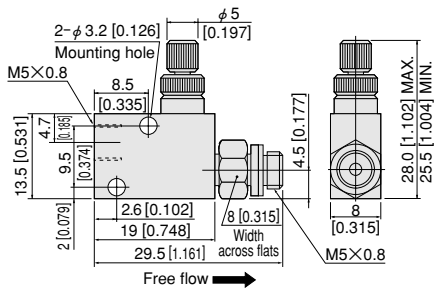

● CS-TSC-US-BF

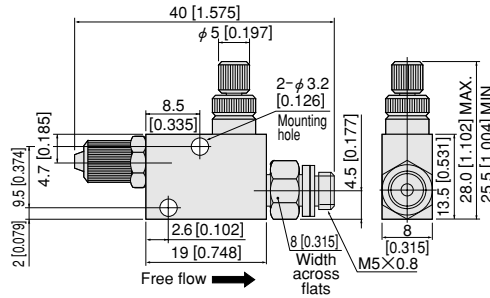

● L type

● CS-TSC-L

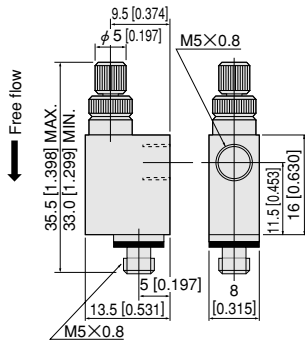

● CS-TSC-L-BF

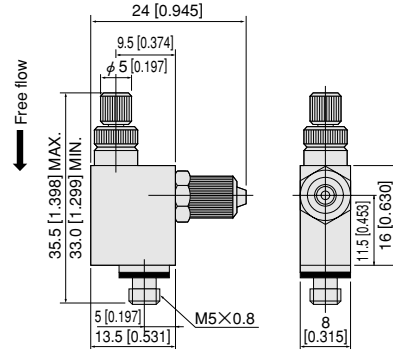

Flow Rate Characteristics

● Controlled flow

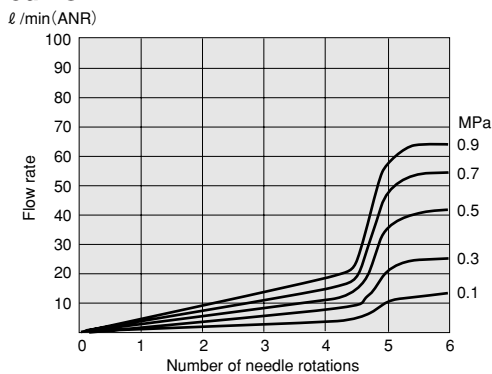

1 ℓ/min = 0.0353ft<sup>3</sup>/min.

● Free flow

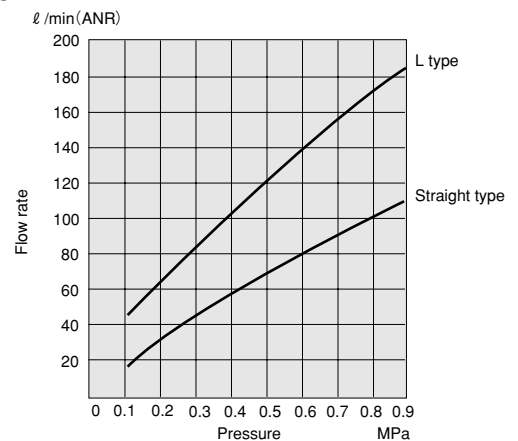

1MPa = 145psi. 1 ℓ/min = 0.0353ft<sup>3</sup>/min.



# Koganei Clean System products provide complete support for the maintenance of a clean environment inside the cleanroom.

Koganei Clean System products meet the needs of the ultra-clean production environment. In everything from actuators and valves to air preparation and auxiliary equipment, anti-corrosion materials processing and other Koganei-developed design concepts serve to prevent particle contamination within the cleanroom. These perfectly designed mechanisms, which resolve even the slightest leaks to the outside during operations, have already won a high level of reliability.

## Koganei Cleanliness

There is currently no standard in JIS or elsewhere for methods of evaluating cleanliness for pneumatic equipment in the cleanroom specifications. Therefore, to measure the effects of cleanroom contamination by pneumatic equipment, Koganei has decided to use “number of particles generated per 10 operations,” rather than particle density. Koganei has also developed classifications for application classes in cleanroom, based on JIS and other upper limit density tables, and on the company’s own experience.

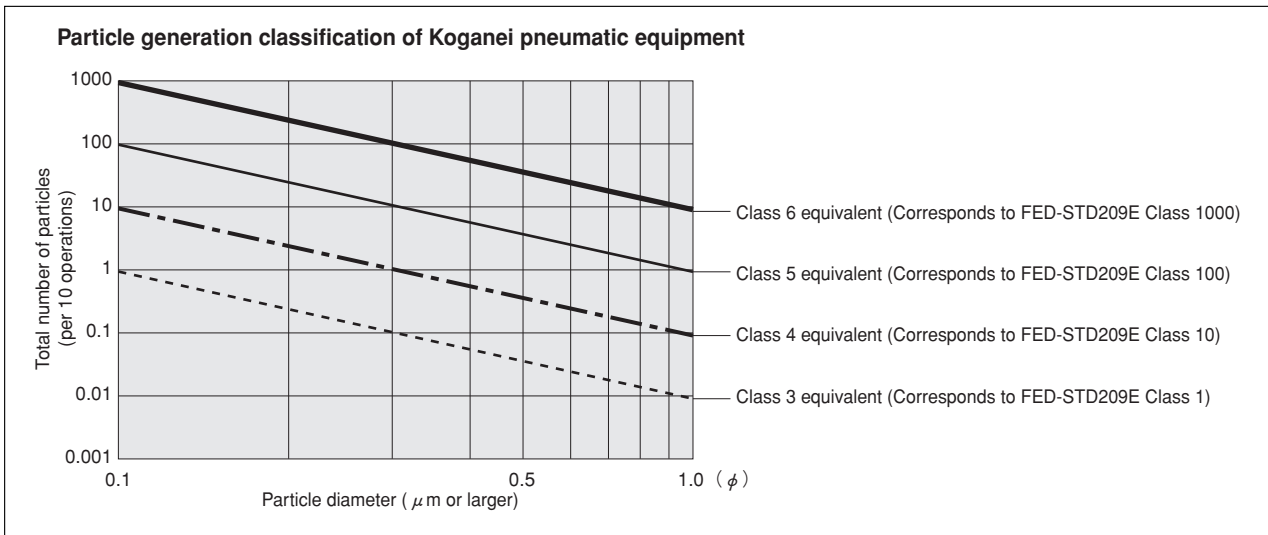

- Remarks:
1. In the above table, product performance in terms of the number of particles generated per 10 operations is expressed as the upper limit of particles corresponding to the equivalent JIS or ISO class.
  2. In the above table, values in the JIS, ISO, and FED-STD upper limit density tables are calculated as upper density per liter.
  3. The classes shown are clean levels as classified in JIS and ISO.

From the above definitions, the Koganei clean level classes can be viewed as the level of average contamination per liter of surrounding air over a period of 10 operations in cleanroom. Air ventilation in cleanrooms is usually faster than 1 cycle per minute, and clean volumetric capacity is usually larger than 1 liter, which should provide a sufficient safety margin in practice.

Caution: The above conclusions are based on an ideal situation in which air ventilation is being implemented. For specific cases where air ventilation is not ensured, caution is needed since the clean classes cannot be maintained.

**The clean system diagrams shown here are for Class 5 equivalent products. For Class 4 or Class 3 equivalent products, consult us.**

# Evaluations of Cleanliness

Koganei has therefore specified its in-house measurement methods, to conduct evaluations on the cleanroom rating.

The number of particles of the Air Cylinder Cleanroom Specification is measured as shown in the method below.

## 1. Measurement conditions

1-1 Test circuit: Figure 1 (no suction), Figure 2 (with suction)

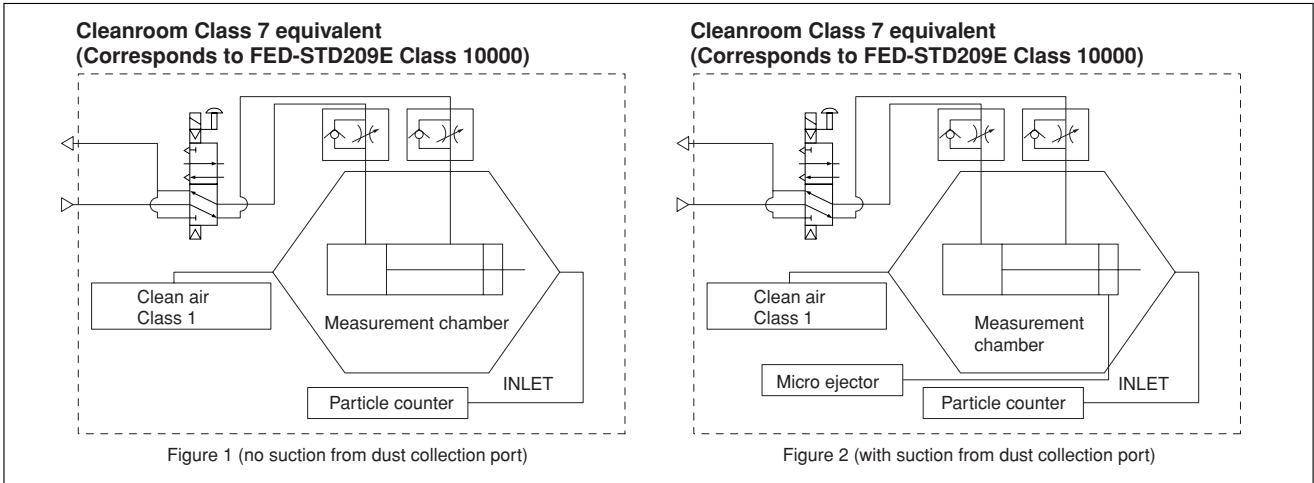

1-2 Operating conditions of tested cylinder

- Operating frequency: 1Hz
- Average speed: 500mm/s [20in./sec.]
- Applied pressure: 0.5MPa [73psi.]
- Suction condition: Microejector ME05, Primary side: 0.5MPa [73psi.] applied, Tube:  $\phi 6$  [0.236in.]
- Mounting direction: Vertical
- Chamber volume: 8.3  $\ell$  [0.293ft.<sup>3</sup>]

## 2. Particle counter

- Manufacturer/model: RION/KM20
- Suction flow rate: 28.3  $\ell$  /min [1ft.<sup>3</sup>/min.]
- Particle diameter: 0.1  $\mu\text{m}$ , 0.2  $\mu\text{m}$ , 0.3  $\mu\text{m}$ , 0.5  $\mu\text{m}$ , 0.7  $\mu\text{m}$ , 1.0  $\mu\text{m}$

## 3. Measurement method

- 3-1 Confirmation of number of particles in the measurement system  
Under the conditions in the above 1 and 2, using a particle counter to measure the sample for 9 minutes without operating the measurement sample, and confirmed the measured number of particle is 1 piece or less.
- 3-2 Measurement under operation  
Under the conditions in the above 1 and 2, operating the measurement sample for 36 minutes, and measured the total values in the latter half of 18 minutes test.
- 3-3 Reconfirmation  
Performed the measurement in 3-1 again, to reconfirm the number of particles in the measurement system.

## 4. Measurement results

### ● Cleanroom specification

Jig Cylinder (no suction from dust collection port)

Particle generation over 1 million operations (CS-CDA16 $\times$ 30)

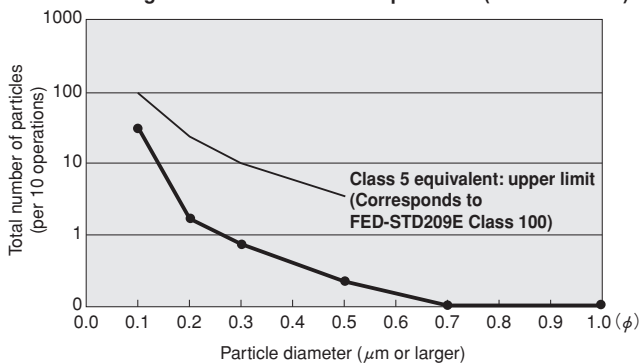

### ● Cleanroom specification

Slim Cylinder (with suction from dust collection port)

Particle generation over 1 million operations (CS-DA20 $\times$ 100)

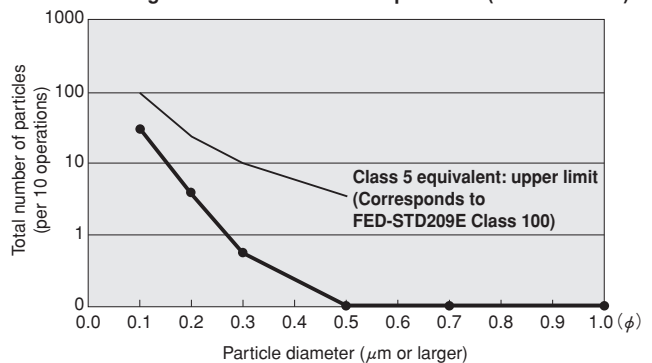

For “safety precautions” listed in the Clean System Product Drawings, see the materials below.

- For actuators, see “Safety Precautions” on p. 45 of the Actuators General Catalog .
- For valves, see “Safety Precautions” on p. 31 of the Valves General Catalog.
- For air treatment and auxiliary equipment, see “Safety Precautions” on p.31 of the General Catalog of Air Treatment, Auxiliary, Vacuum.

**Symbol**

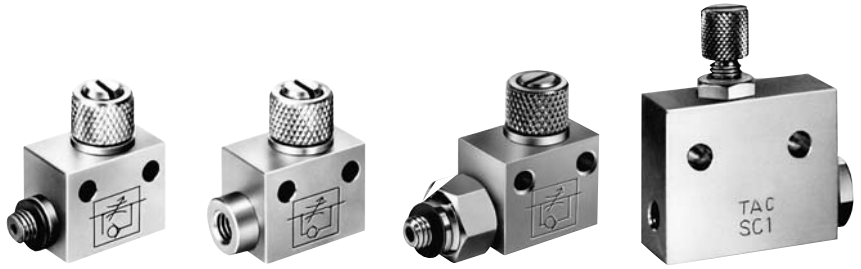
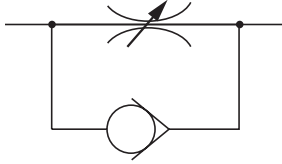

**Specifications**

Item	Model	CS-SC0	CS-SC0-F	CS-SC0-US	CS-SC0-UL	CS-SC1	CS-SC2
Piping type		Female thread	Male thread	Union male thread Straight   Elbow		Female thread	
Port size		M5×0.8				Rc1/8	
Operating pressure range	MPa [psi.]	0~0.9 [0~131]					
Proof pressure	MPa [psi.]	1.32 [191]					
Cracking pressure	MPa [psi.]	0.05 [7]				0.04 [6]	0.03 [4]
Operating temperature range	°C [°F]	5~60 [41~140]					
Mass	g [oz.]	30 [1.06]	35 [1.23]	36 [1.27]	88 [3.10]	55 [1.94]	

**Inner Construction and Major Parts**

● CS-SC0

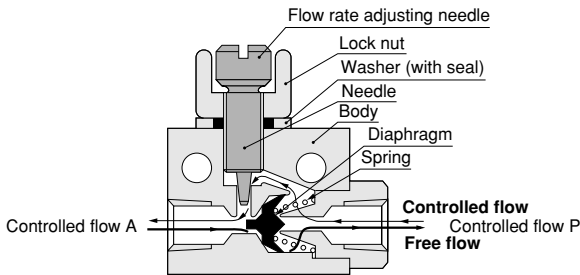

● CS-SC1

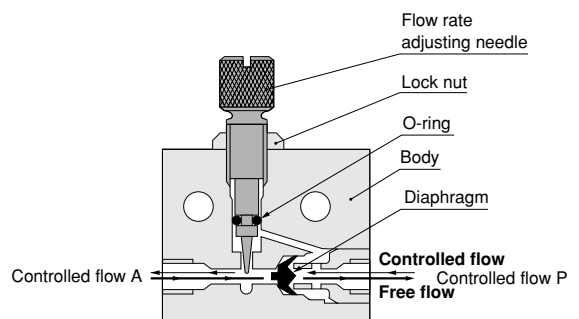

● CS-SC2

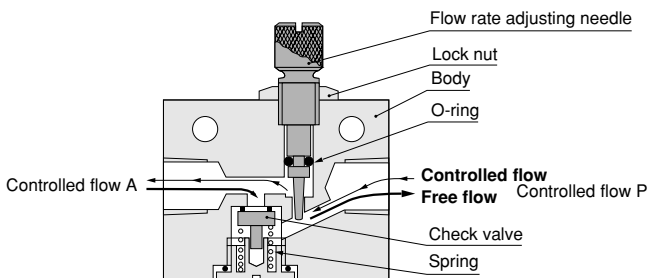

**Major Parts and Materials**

Parts	Materials
Body	Brass (nickel electroplated) <sup>Note</sup>
Needle	Stainless steel
Lock nut	Brass (nickel electroplated)
Check valve	Synthetic rubber (NBR)
O-ring	
Flow rate adjusting needle	Brass (nickel electroplated)

Note: CS-SC2 is aluminum alloy (anodized).

# Dimensions mm [in.]

## ● CS-SC0

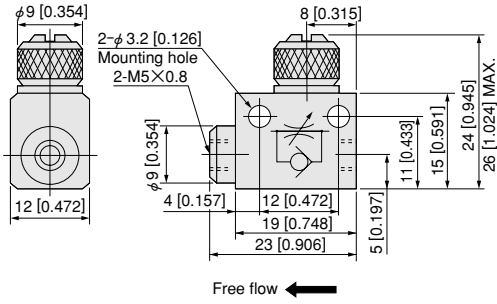

## ● CS-SC0-US

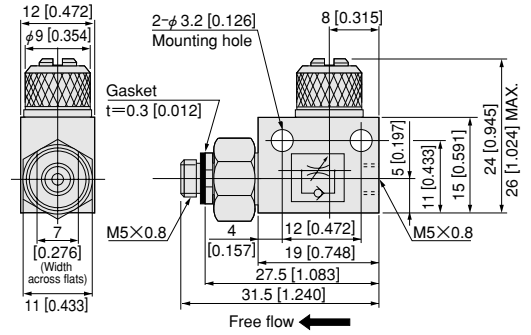

## ● CS-SC0-F

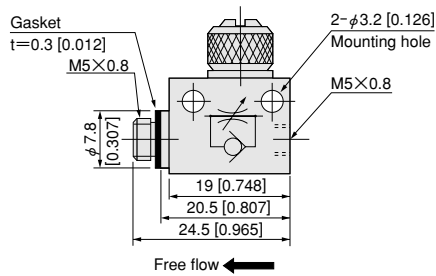

## ● CS-SC0-UL

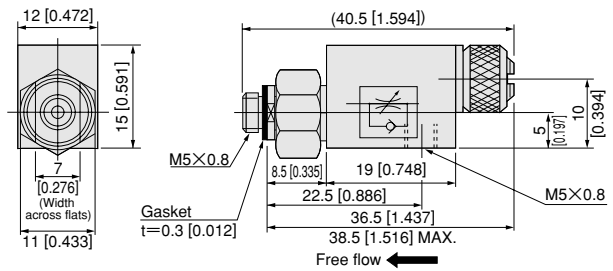

## ● CS-SC1

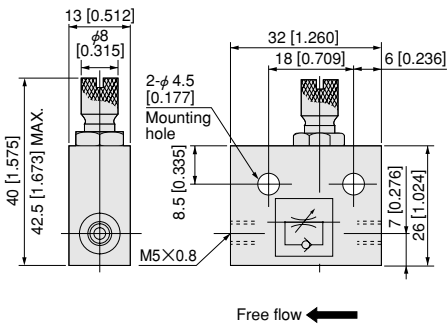

## ● CS-SC2

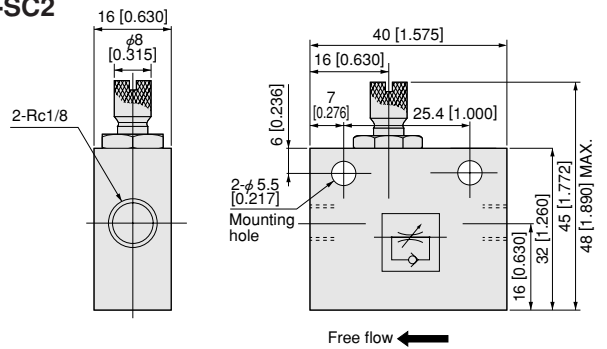

# Flow Rate Characteristics

## ● CS-SC0

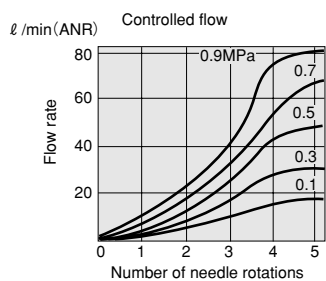

## ● CS-SC1

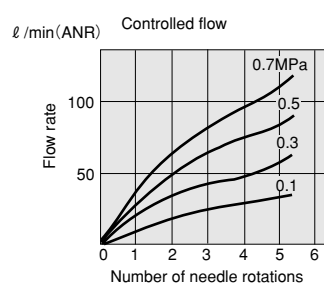

## ● CS-SC2

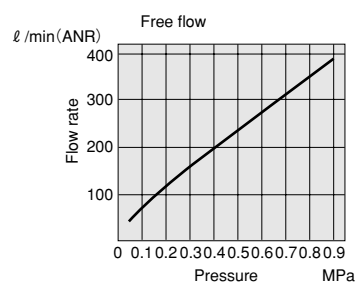
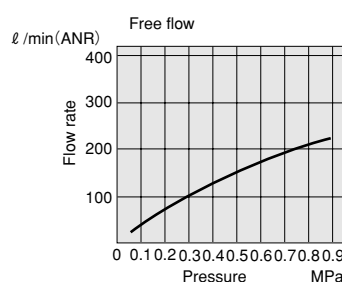
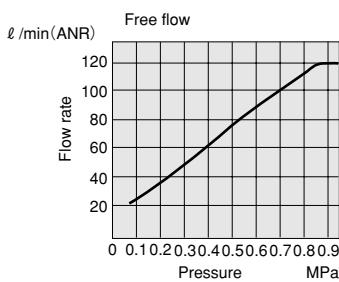
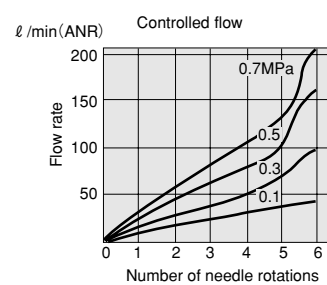

1  $\ell/\text{min} = 0.0353\text{ft}^3/\text{min}$ .

1 MPa = 145psi.  
1  $\ell/\text{min} = 0.0353\text{ft}^3/\text{min}$ .



# Koganei Clean System products provide complete support for the maintenance of a clean environment inside the cleanroom.

Koganei Clean System products meet the needs of the ultra-clean production environment. In everything from actuators and valves to air preparation and auxiliary equipment, anti-corrosion materials processing and other Koganei-developed design concepts serve to prevent particle contamination within the cleanroom. These perfectly designed mechanisms, which resolve even the slightest leaks to the outside during operations, have already won a high level of reliability.

## Koganei Cleanliness

There is currently no standard in JIS or elsewhere for methods of evaluating cleanliness for pneumatic equipment in the cleanroom specifications. Therefore, to measure the effects of cleanroom contamination by pneumatic equipment, Koganei has decided to use “number of particles generated per 10 operations,” rather than particle density. Koganei has also developed classifications for application classes in cleanroom, based on JIS and other upper limit density tables, and on the company’s own experience.

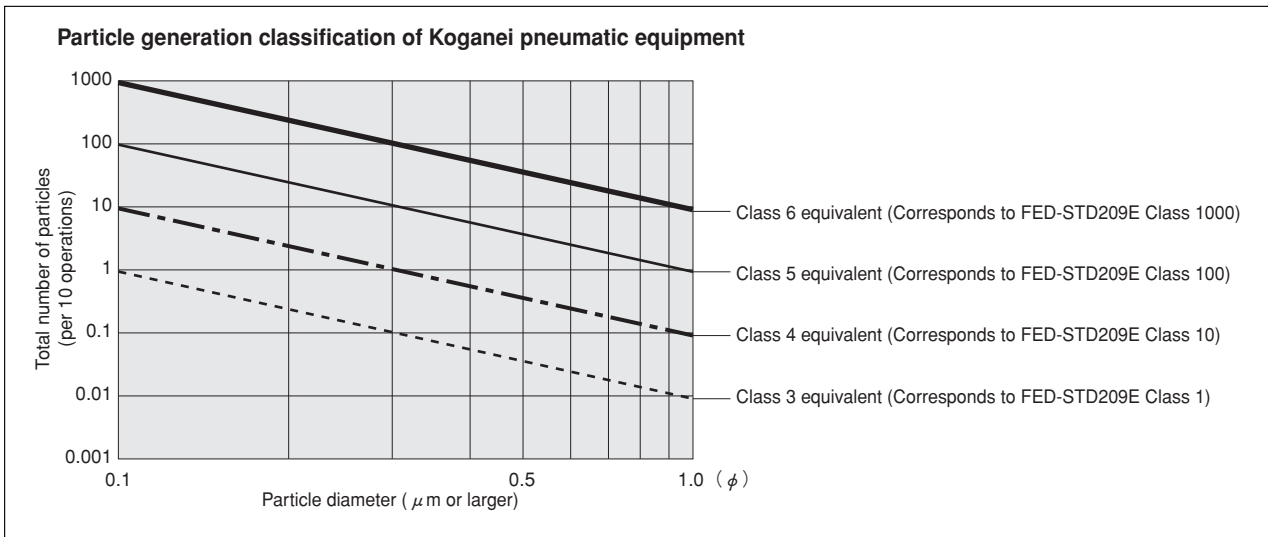

- Remarks:
1. In the above table, product performance in terms of the number of particles generated per 10 operations is expressed as the upper limit of particles corresponding to the equivalent JIS or ISO class.
  2. In the above table, values in the JIS, ISO, and FED-STD upper limit density tables are calculated as upper density per liter.
  3. The classes shown are clean levels as classified in JIS and ISO.

From the above definitions, the Koganei clean level classes can be viewed as the level of average contamination per liter of surrounding air over a period of 10 operations in cleanroom. Air ventilation in cleanrooms is usually faster than 1 cycle per minute, and clean volumetric capacity is usually larger than 1 liter, which should provide a sufficient safety margin in practice.

Caution: The above conclusions are based on an ideal situation in which air ventilation is being implemented. For specific cases where air ventilation is not ensured, caution is needed since the clean classes cannot be maintained.

**The clean system diagrams shown here are for Class 5 equivalent products. For Class 4 or Class 3 equivalent products, consult us.**

# Evaluations of Cleanliness

Koganei has therefore specified its in-house measurement methods, to conduct evaluations on the cleanroom rating.

The number of particles of the Air Cylinder Cleanroom Specification is measured as shown in the method below.

## 1. Measurement conditions

1-1 Test circuit: Figure 1 (no suction), Figure 2 (with suction)

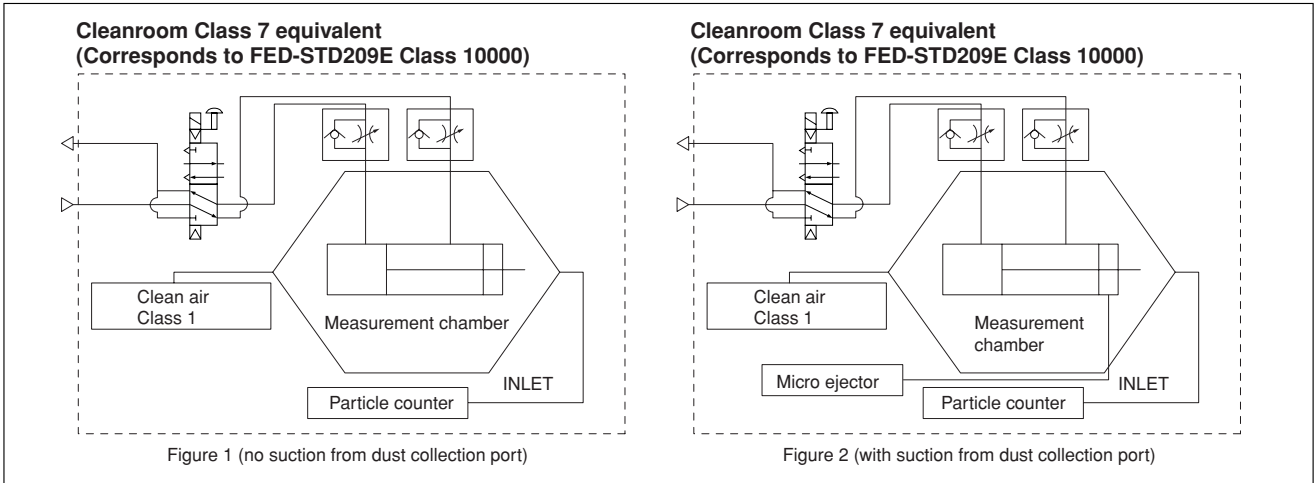

1-2 Operating conditions of tested cylinder

- Operating frequency: 1Hz
- Average speed: 500mm/s [20in./sec.]
- Applied pressure: 0.5MPa [73psi.]
- Suction condition: Microejector ME05, Primary side: 0.5MPa [73psi.] applied, Tube:  $\phi 6$  [0.236in.]
- Mounting direction: Vertical
- Chamber volume: 8.3  $\ell$  [0.293ft.<sup>3</sup>]

## 2. Particle counter

- Manufacturer/model: RION/KM20
- Suction flow rate: 28.3  $\ell$  /min [1ft.<sup>3</sup>/min.]
- Particle diameter: 0.1  $\mu\text{m}$ , 0.2  $\mu\text{m}$ , 0.3  $\mu\text{m}$ , 0.5  $\mu\text{m}$ , 0.7  $\mu\text{m}$ , 1.0  $\mu\text{m}$

## 3. Measurement method

- 3-1 Confirmation of number of particles in the measurement system  
Under the conditions in the above 1 and 2, using a particle counter to measure the sample for 9 minutes without operating the measurement sample, and confirmed the measured number of particle is 1 piece or less.
- 3-2 Measurement under operation  
Under the conditions in the above 1 and 2, operating the measurement sample for 36 minutes, and measured the total values in the latter half of 18 minutes test.
- 3-3 Reconfirmation  
Performed the measurement in 3-1 again, to reconfirm the number of particles in the measurement system.

## 4. Measurement results

### ● Cleanroom specification

Jig Cylinder (no suction from dust collection port)

Particle generation over 1 million operations (CS-CDA16 $\times$ 30)

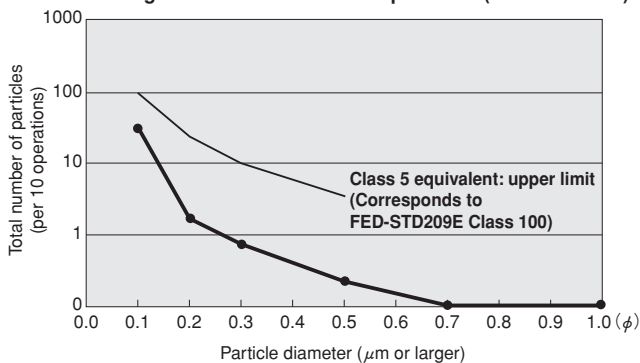

### ● Cleanroom specification

Slim Cylinder (with suction from dust collection port)

Particle generation over 1 million operations (CS-DA20 $\times$ 100)

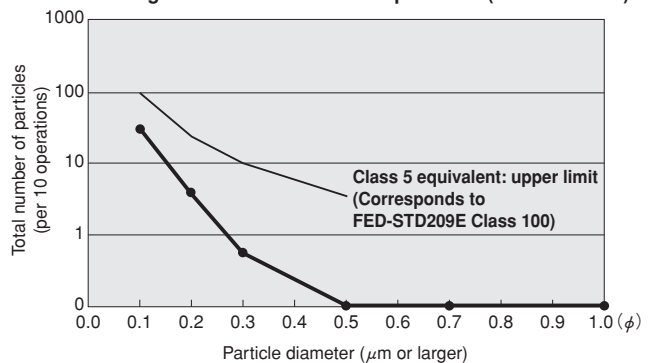

For “safety precautions” listed in the Clean System Product Drawings, see the materials below.

- For actuators, see “Safety Precautions” on p. 45 of the Actuators General Catalog .
- For valves, see “Safety Precautions” on p. 31 of the Valves General Catalog.
- For air treatment and auxiliary equipment, see “Safety Precautions” on p.31 of the General Catalog of Air Treatment, Auxiliary, Vacuum.

# SPEED CONTROLLERS SCL SERIES

Male thread; R1/8, R1/4 Female thread; Rc1/8, Rc1/4

## Symbol

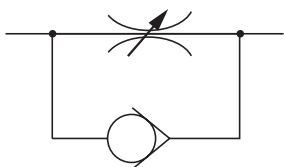

## Specifications

Item	Model	CS-SCL1	CS-SCL2
Mounting type		Male thread specification, enabling direct cylinder mounting	
Port size		Controlled flow P: male thread R1/8 A: female thread Rc1/8	Controlled flow P: male thread R1/4 A: female thread Rc1/4
Media		Air	
Operating pressure range	MPa [psi.]	0~0.9 [0~131]	
Proof pressure	MPa [psi.]	1.32 [191]	
Cracking pressure	MPa [psi.]	0.06 [9]	
Operating temperature range	°C [°F]	5~60 [41~140]	
Mass	g [oz.]	46 [1.62]	125 [4.41]



## Inner Construction and Major Parts

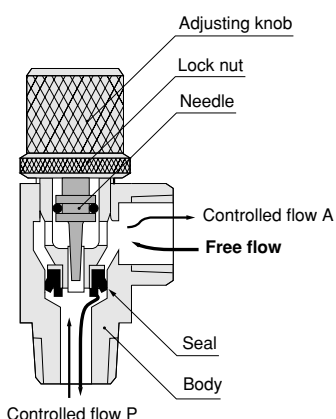

## Major Parts and Materials

Parts	Materials
Body	Brass (nickel plated)
Needle	Stainless steel
Seal	Synthetic rubber (NBR)

## Dimensions mm [in.]

### CS-SCL1

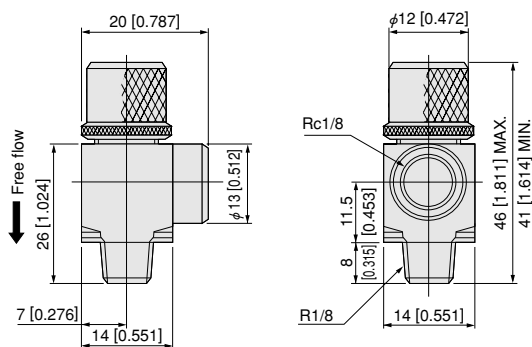

### CS-SCL2

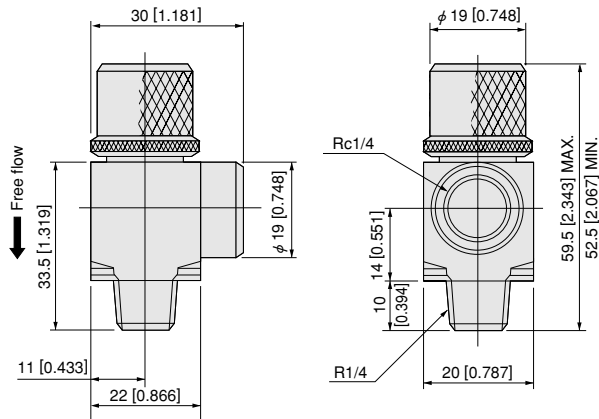

## Flow Rate Characteristics

### CS-SCL1

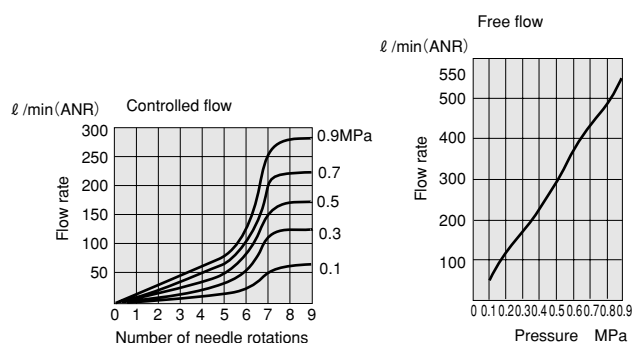

### CS-SCL2

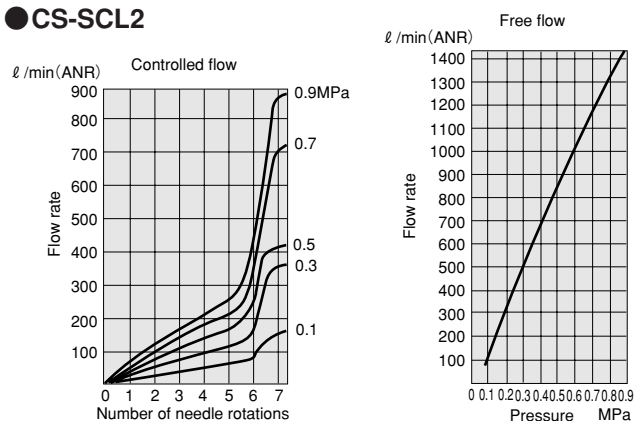

1MPa = 145psi. 1 l/min = 0.0353ft<sup>3</sup>/min.



# Koganei Clean System products provide complete support for the maintenance of a clean environment inside the cleanroom.

Koganei Clean System products meet the needs of the ultra-clean production environment. In everything from actuators and valves to air preparation and auxiliary equipment, anti-corrosion materials processing and other Koganei-developed design concepts serve to prevent particle contamination within the cleanroom. These perfectly designed mechanisms, which resolve even the slightest leaks to the outside during operations, have already won a high level of reliability.

## Koganei Cleanliness

There is currently no standard in JIS or elsewhere for methods of evaluating cleanliness for pneumatic equipment in the cleanroom specifications. Therefore, to measure the effects of cleanroom contamination by pneumatic equipment, Koganei has decided to use “number of particles generated per 10 operations,” rather than particle density. Koganei has also developed classifications for application classes in cleanroom, based on JIS and other upper limit density tables, and on the company’s own experience.

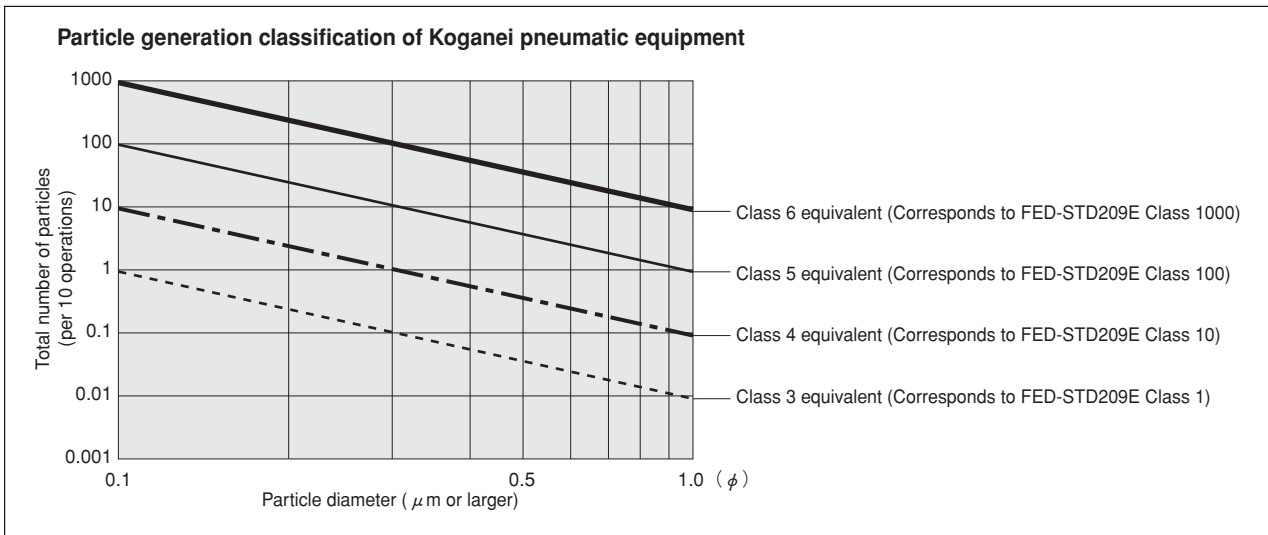

- Remarks:
1. In the above table, product performance in terms of the number of particles generated per 10 operations is expressed as the upper limit of particles corresponding to the equivalent JIS or ISO class.
  2. In the above table, values in the JIS, ISO, and FED-STD upper limit density tables are calculated as upper density per liter.
  3. The classes shown are clean levels as classified in JIS and ISO.

From the above definitions, the Koganei clean level classes can be viewed as the level of average contamination per liter of surrounding air over a period of 10 operations in cleanroom. Air ventilation in cleanrooms is usually faster than 1 cycle per minute, and clean volumetric capacity is usually larger than 1 liter, which should provide a sufficient safety margin in practice.

Caution: The above conclusions are based on an ideal situation in which air ventilation is being implemented. For specific cases where air ventilation is not ensured, caution is needed since the clean classes cannot be maintained.

**The clean system diagrams shown here are for Class 5 equivalent products. For Class 4 or Class 3 equivalent products, consult us.**

# Evaluations of Cleanliness

Koganei has therefore specified its in-house measurement methods, to conduct evaluations on the cleanroom rating.

The number of particles of the Air Cylinder Cleanroom Specification is measured as shown in the method below.

## 1. Measurement conditions

1-1 Test circuit: Figure 1 (no suction), Figure 2 (with suction)

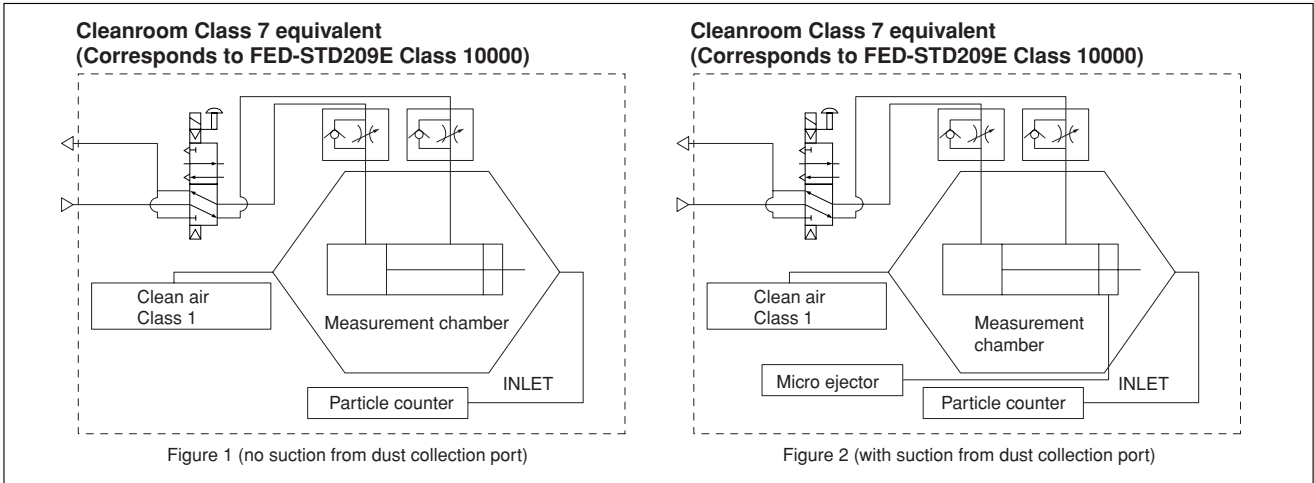

1-2 Operating conditions of tested cylinder

- Operating frequency: 1Hz
- Average speed: 500mm/s [20in./sec.]
- Applied pressure: 0.5MPa [73psi.]
- Suction condition: Microejector ME05, Primary side: 0.5MPa [73psi.] applied, Tube:  $\phi 6$  [0.236in.]
- Mounting direction: Vertical
- Chamber volume: 8.3  $\ell$  [0.293ft.<sup>3</sup>]

## 2. Particle counter

- Manufacturer/model: RION/KM20
- Suction flow rate: 28.3  $\ell$  /min [1ft.<sup>3</sup>/min.]
- Particle diameter: 0.1  $\mu\text{m}$ , 0.2  $\mu\text{m}$ , 0.3  $\mu\text{m}$ , 0.5  $\mu\text{m}$ , 0.7  $\mu\text{m}$ , 1.0  $\mu\text{m}$

## 3. Measurement method

- 3-1 Confirmation of number of particles in the measurement system  
Under the conditions in the above 1 and 2, using a particle counter to measure the sample for 9 minutes without operating the measurement sample, and confirmed the measured number of particle is 1 piece or less.
- 3-2 Measurement under operation  
Under the conditions in the above 1 and 2, operating the measurement sample for 36 minutes, and measured the total values in the latter half of 18 minutes test.
- 3-3 Reconfirmation  
Performed the measurement in 3-1 again, to reconfirm the number of particles in the measurement system.

## 4. Measurement results

### ● Cleanroom specification

Jig Cylinder (no suction from dust collection port)

Particle generation over 1 million operations (CS-CDA16 $\times$ 30)

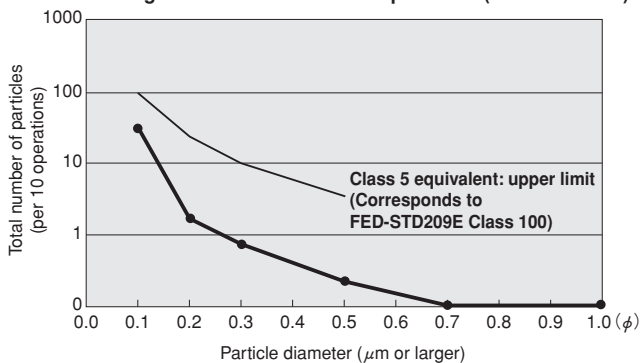

### ● Cleanroom specification

Slim Cylinder (with suction from dust collection port)

Particle generation over 1 million operations (CS-DA20 $\times$ 100)

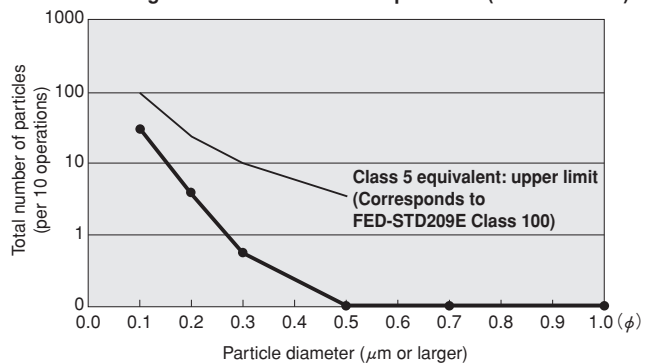

For “safety precautions” listed in the Clean System Product Drawings, see the materials below.

- For actuators, see “Safety Precautions” on p. 45 of the Actuators General Catalog .
- For valves, see “Safety Precautions” on p. 31 of the Valves General Catalog.
- For air treatment and auxiliary equipment, see “Safety Precautions” on p.31 of the General Catalog of Air Treatment, Auxiliary, Vacuum.



**Symbol**

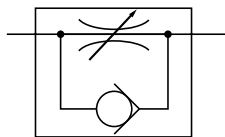

**Specifications**

Item	Model	CS-KSC11	CS-KSC22
Port size	Rc	1/8	1/4
Operating pressure range	MPa [psi.]	0.9 [131]	
Proof pressure	MPa [psi.]	1.3 [189]	
Cracking pressure	MPa [psi.]	0.06 [9]	0.02 [3]
Operating temperature range	°C [°F]	5~60 [41~140]	
Mass	g [oz.]	90 [3.17]	130 [4.59]

**Inner Construction and Major Parts**

● **CS-KSC11**

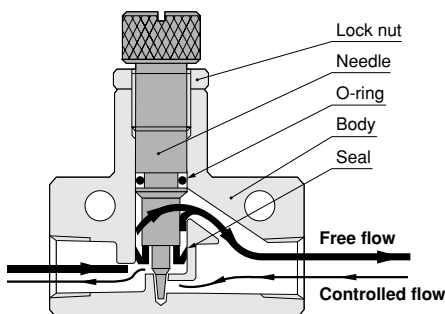

● **CS-KSC22**

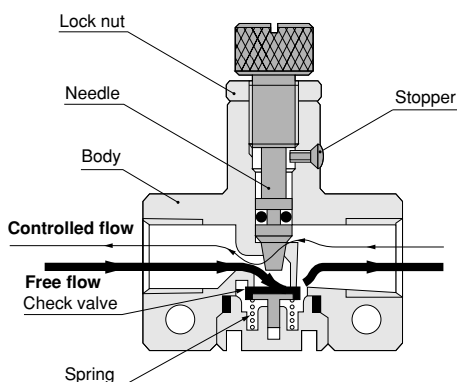

**Major Parts and Materials**

Parts	Materials
Body	Zinc die-casting
Needle, lock nut	Brass (nickel plated)

**Dimensions mm [in.]**

● **CS-KSC11**

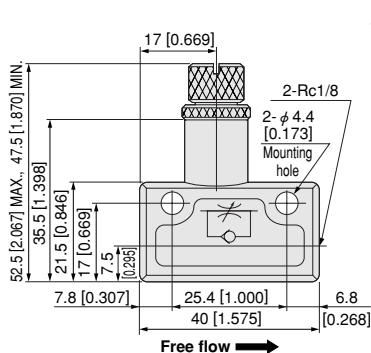

● **CS-KSC22**

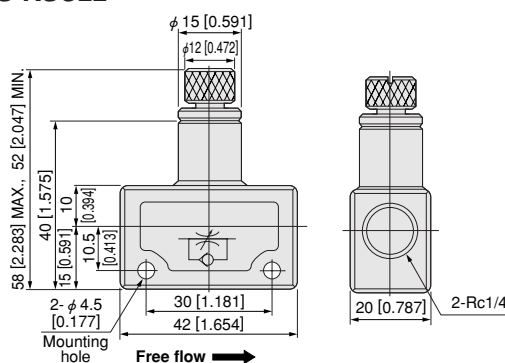

**Flow Rate Characteristics**

● **CS-KSC11**

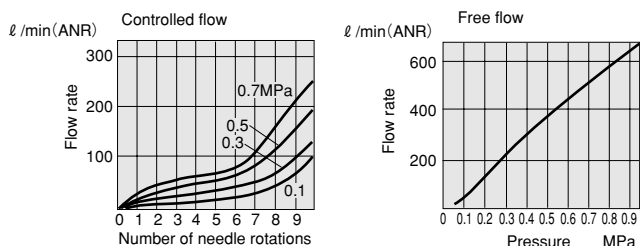

1MPa = 145psi. 1 l/min = 0.0353ft<sup>3</sup>/min.

● **CS-KSC22**

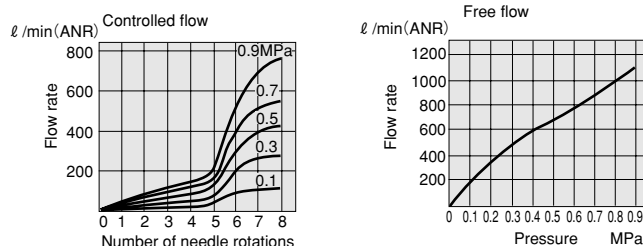

1MPa = 145psi. 1 l/min = 0.0353ft<sup>3</sup>/min.