

MoBo Actuator (MA Series)

MoBo Actuator

External Ball Screw type (MoBo) is built in this series, what we call MoBo Actuators. All of MoBo Actuators are produced as customized products, in accordance with customer's order.



Features

More compact design of Unit products in longitudinal dimension became reality by using Direct Motor Drive Ball Screws / Resin Lead Screws.

Variation

There are several kinds of MoBo Actuator shown below. Each Actuator has a different kinds of Ball Screw / Lead Screw inside.

1) Precision Ball Screw type

High accuracy in both Repeatability and Lost motion by using Precision Ball Screw.

2) Rolled Ball Screw type

Reasonable price and accuracy have been achieved by using Rolled Ball Screw.

3) Resin Lead Screw type

It can be used without oiling in normal environment, because lubricating agent is incorporated in Resin Nut.

Model number notation

MA S - G 020 - 015 N R

① ② ③ ④ ⑤ ⑥ ⑦

① Series No.

MA : MoBo Actuator Series

② Actuator type

S : Slider type

③ Lead Screw / Ball Screw

G : Precision Ball Screw

R : Rolled Ball Screw

Re : Resin Lead Screw

④ Lead/Pitch (mm): 020 means 2mm

⑤ Travel (mm): 015 means 15mm

⑥ Connector type

N : No connector (Bare)

H : HIROSE RP17

E : EI connector (TE Connectivity)

⑦ Direction of Motor leads

R : Right (from Shaft end side)

L : Left

Structure

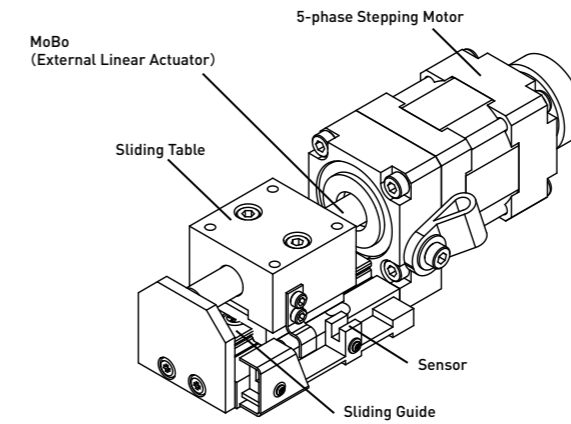

Specifications

Overall specifications for MoBo Actuators are shown in Table below. For further information, please see dimension Table.

Model	MAS-G010-015	MAS-G010-030	MAS-R010-015	MAS-R010-030	MAS-Re020-015	MAS-Re020-030
Travel	15mm	30mm	15mm	30mm	15mm	30mm
Drive Screw	Precision Ball Screw Lead = 1mm		Rolled Ball Screw Lead = 1mm		Resin Lead Screw Lead = 2mm	
Sliding Guide	Slide Guide rail					
Body Material	Aluminum					
Mass	200g	210g	200g	210g	200g	210g
Resolution	0.002mm		0.002mm		0.004mm	
Repeatability	Max. ±0.005mm		Max. ±0.01mm		Max. ±0.05mm	
Lost motion	Max. 0.005mm		Max. 0.01mm		Max. 0.05mm	
Horizontal Load Capacity	Max. 29.4N		Max. 29.4N		Max. 9.8N	
Vertical Load Capacity	Max. 19.6N		Max. 19.6N		Max. 4.9N	
Permissible speed	0.4~20mm/sec		0.4~20mm/sec		0.8~15mm/sec	
Maximum acceleration	0.1m/sec ²					
Permissible Moment Mp (Pitching)	0.16Nm	** In case of no load in My & Mr direction				
Permissible Moment My (Yawing)	0.10Nm	** In case of no load in Mp & Mr direction				
Permissible Moment Mr (Rolling)	0.20Nm	** In case of no load in Mp & My direction				
Operating Temp.	0~40°C (without any due condensation)					
Lubrication	Ball Screw : KSS MSG No.2 Sliding Guide : KSS MSG No.2				Lead Screw: Sumitec Liquid H20 Sliding Guide: KSS MSG No.2	

• Motor : 5-phase Stepping Motor □24(NEMA 10) , 0.75A/phase

• Photo Micro sensor : EE-SX1103(Omron) , DC5V 50mA (Motor side and Travel end)

Standard style of MAS series

Drive Ball Screw + 5-phase Stepping Motor

MAS□24 / MAS NEMA 11

Shaft dia. $\phi 6$

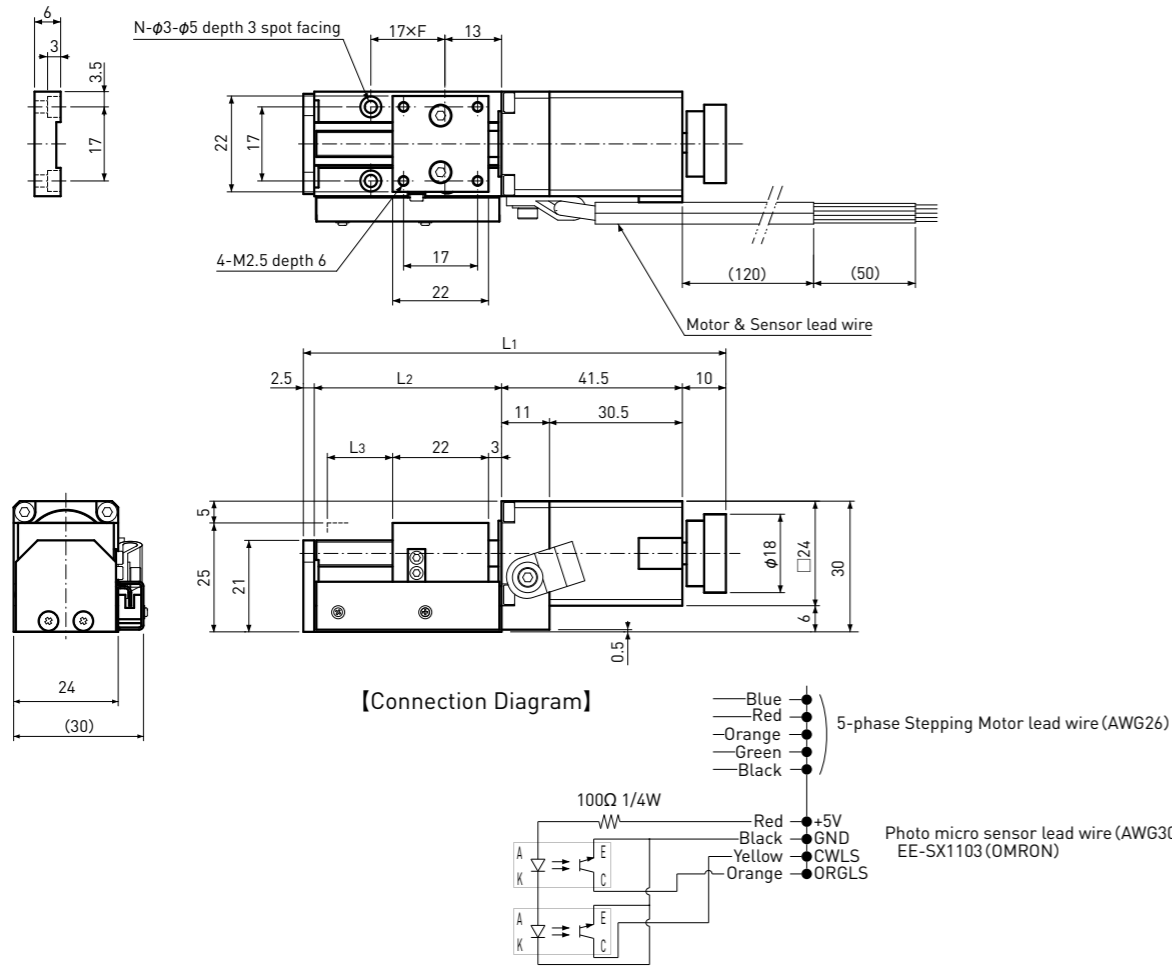

[Connector choice].

Please designate connector type below.
No connector if there is no designation.

- None (Bare)
- RP17-13J-12SC (HIROSE)
- EI-Connector (TE connectivity : 172211-6 pins for Motor + 172211-4 pins for Sensor)

[HIROSE RP-Connector]

Upper side (white dot)

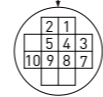

RP17-13J-12SC (female)

1	Stepping Motor (Blue)
2	Stepping Motor (Red)
3	Stepping Motor (Orange)
4	Stepping Motor (Green)
5	Stepping Motor (Black)
6	None
7	5V (Red)
8	GND (Black)
9	CWLS Sensor (Yellow)
10	ORGLS Sensor (orange)
11	None
12	None

[EI-Connector]



172211-6 (male)

1	Stepping Motor (Blue)
2	Stepping Motor (Red)
3	Stepping Motor (Orange)
4	Stepping Motor (Green)
5	Stepping Motor (Black)
6	None



172211-4 (male)

1	5V (Red)
2	GND (Black)
3	CWLS Sensor (Yellow)
4	ORGLS Sensor (Orange)

Common Specifications	
Motor	5-phase Stepping Motor □24, 0.75A / phase
Body Material	Aluminum
Sliding guide	Slide Guide rail(Single)
Photo Sensor (Motor side & travel end)	Omron : EE-SX1103 ※Light-on
Permissible Moment	
Pitching Mp	0.16Nm
Yawing My	0.10Nm
Rolling Mr	0.20Nm
Lubrication	
MSG No.2(KSS original Grease) **Sumitec Liquid H20 for Resin Lead Screw	
Operating Temp.	
0~40°C **No due condensation	

Model Number	Drive Screw type	Travel (mm)	Screw Lead (mm)	Resolution (mm)	Length (mm)					Repeatability max. (mm)	Lost Motion max. (mm)	Load Capacity max. (N/kgf)		Maximum Acceleration (m/sec ²)	Permissible speed (mm/sec)	Mass (g)	Model Number	
					L1	L2	L3	F	N			Hor.	Vert.					
MAS-G010-015NR	Precision Ball Screw	15	1	0.002	97	43	15	1	4	±0.005	0.005	29.4/3.0	19.6/2.0	0.1	0.4~20	200	MAS-G010-015NR	
MAS-R010-015NR	Rolled Ball Screw		1	0.002	97	43	15	1	4	±0.01	0.01	29.4/3.0	19.6/2.0	0.1	0.4~20	200	MAS-R010-015NR	
MAS-Re020-015NR	Resin Lead Screw		2	0.004	0.004	97	43	15	1	4	±0.05	0.05	9.8/1.0	4.9/0.5	0.1	0.8~15	200	MAS-Re020-015NR
MAS-G010-030NR	Precision Ball Screw	30	1	0.002	112	58	30	2	6	±0.005	0.005	29.4/3.0	19.6/2.0	0.1	0.4~20	210	MAS-G010-030NR	
MAS-R010-030NR	Rolled Ball Screw		1	0.002	0.002	112	58	30	2	6	±0.01	0.01	29.4/3.0	19.6/2.0	0.1	0.4~20	210	MAS-R010-030NR
MAS-Re020-030NR	Resin Lead Screw		2	0.004	0.004	112	58	30	2	6	±0.05	0.05	9.8/1.0	4.9/0.5	0.1	0.8~15	210	MAS-Re020-030NR

Note 1) Model Number above is for no-connector and lead wire is set on right side on Motor.
 Note 2) Permissible moment is based on no load in other direction.
 Note 3) Dimension above is our model case, if you need special specifications, please ask KSS representative.
 Note 4) Refer to page Q131 for connection diagrams of recommended Driver (KR-A5CC, KR-A55MC).
 Note 5) Please refer to Technical Description page S106 for the Datum clamp face of the Actuator.

Connection diagrams

● For Flex series

[SD4030B3 Connection diagrams]

Applicable Motor
Minebea Moter 10PM-K202B



[EI connector]

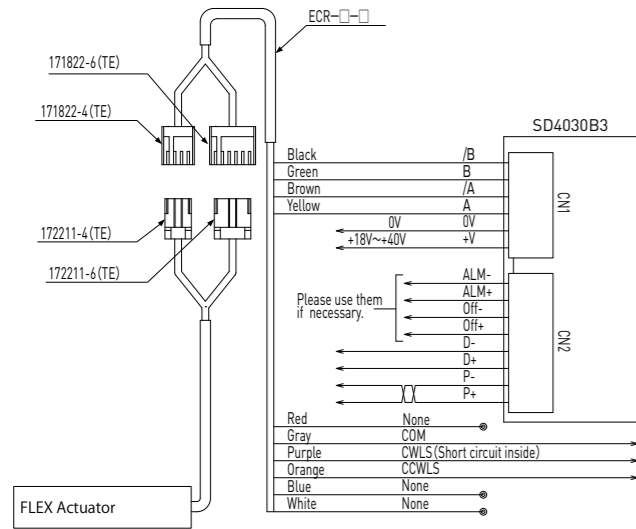

[HIROSE connector]

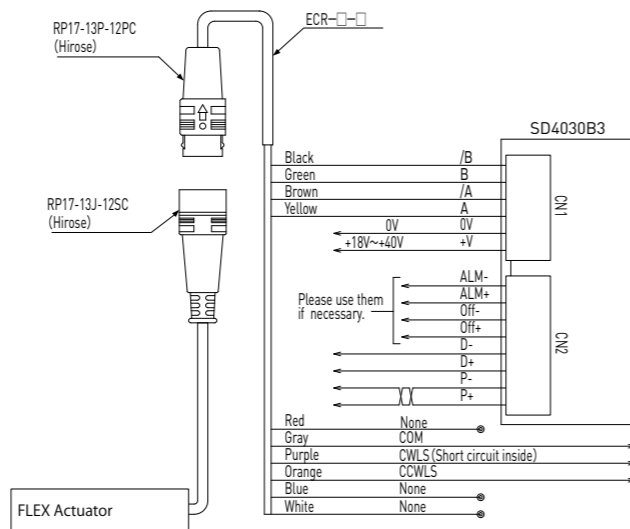

[KR-A55MC Connection diagrams]

Applicable Motor
Oriental Moter PK523HPB



[EI connector]

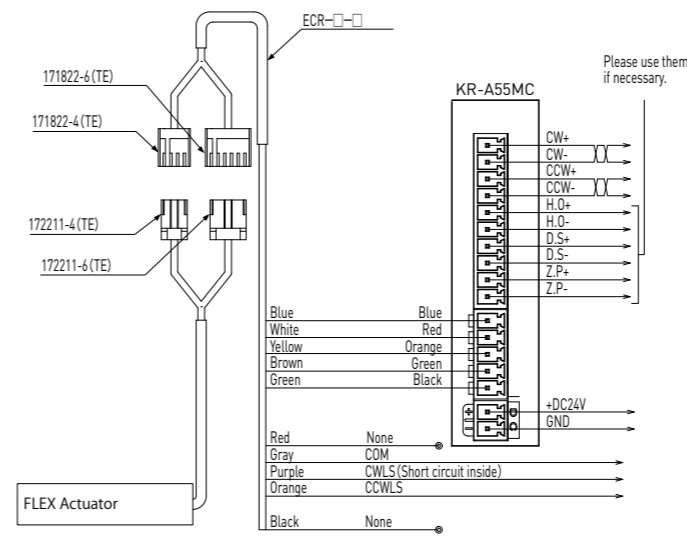

[HIROSE connector]

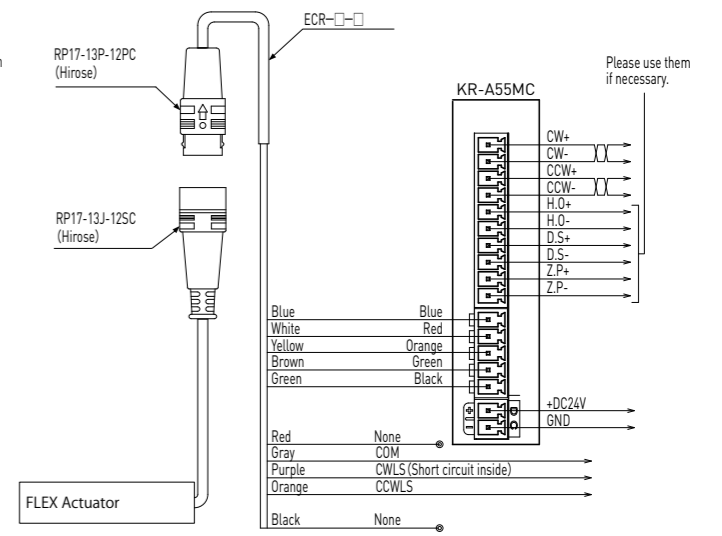

[KR-A5CC Connection diagrams]

Applicable Motor
Oriental Moter PK523HPB



[EI connector]

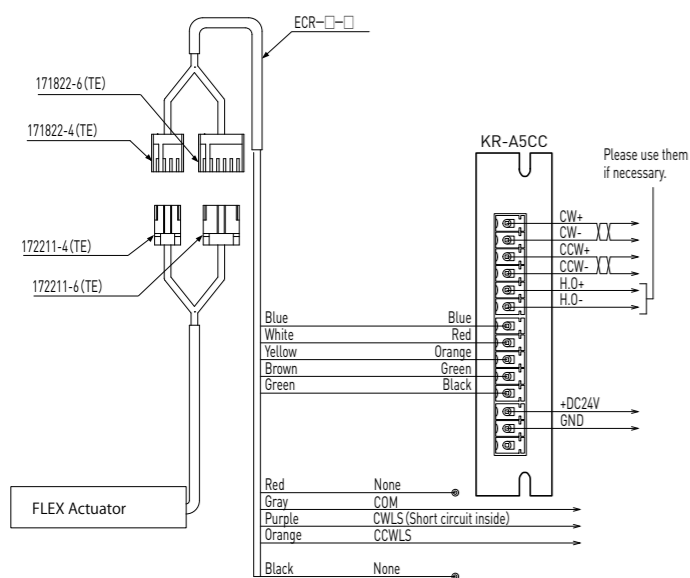

[HIROSE connector]

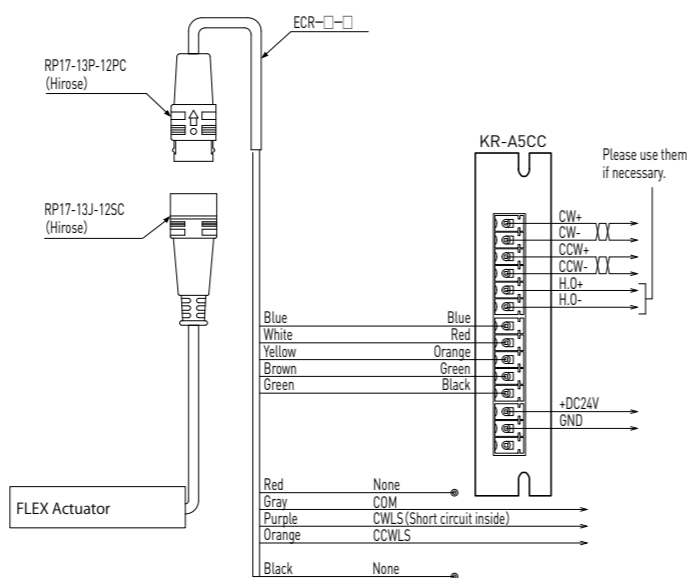

● For CAS series

[SD4015B3 Connection diagrams]

Applicable Motor
Sanyo SH2141-551



[EI connector]

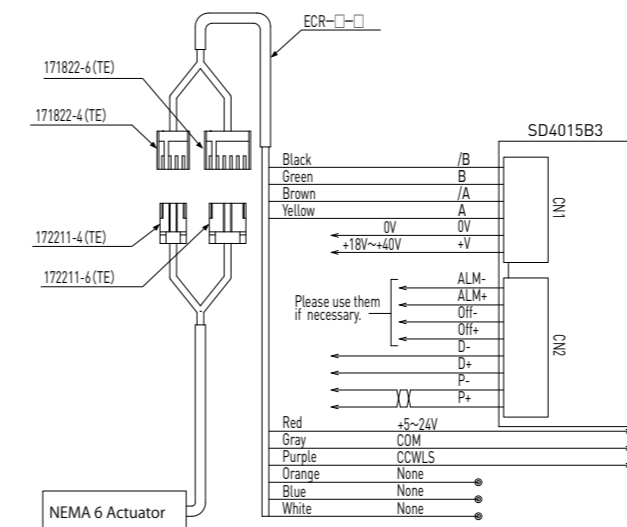

[HIROSE connector]

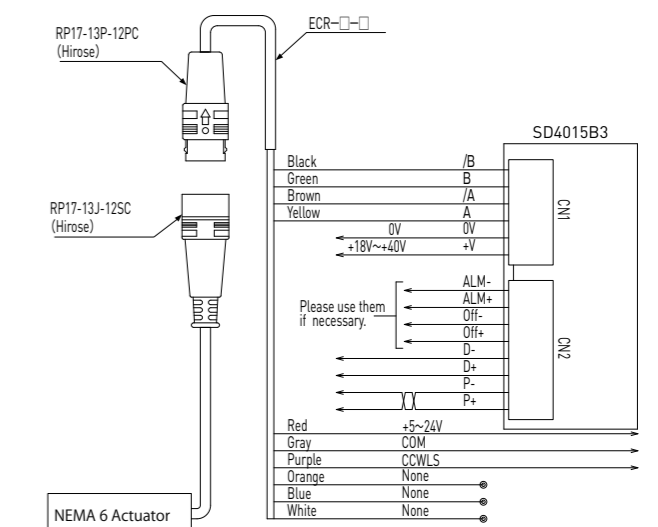

● For MA series

【KR-A5CC Connection diagrams】

Applicable Motor
TAMAGAWA SEIKI Dedicated Motor for Linear Actuator



【EI connector】

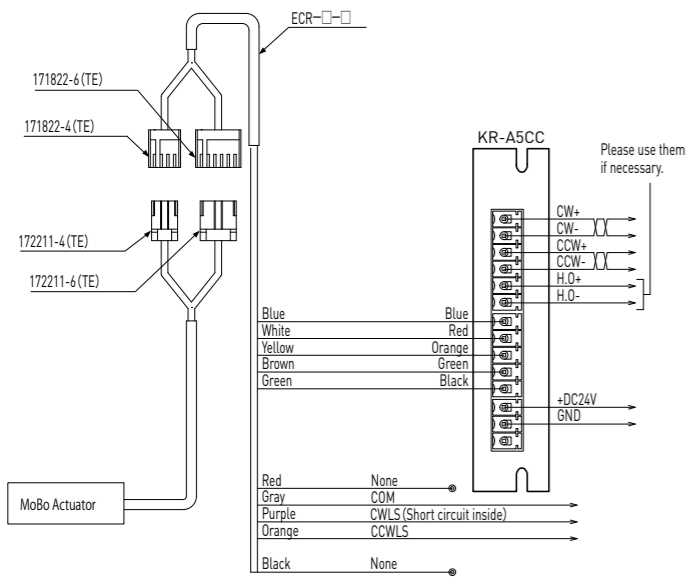

【HIROSE connector】

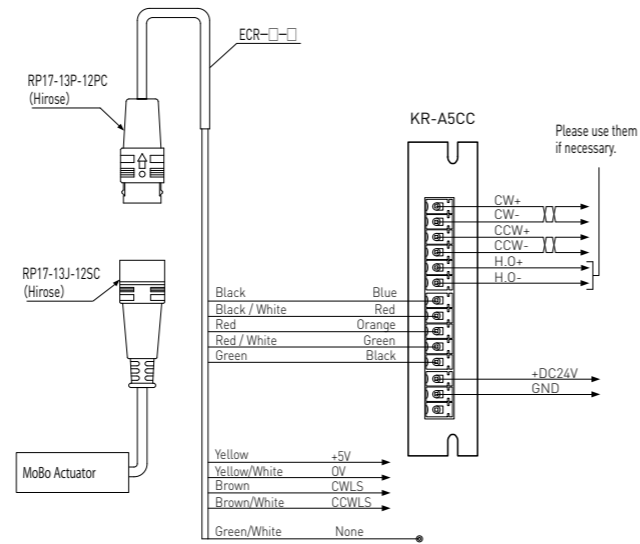

【KR-A55MC Connection diagrams】

Applicable Motor
TAMAGAWA SEIKI Dedicated Motor for Linear Actuator



【EI connector】

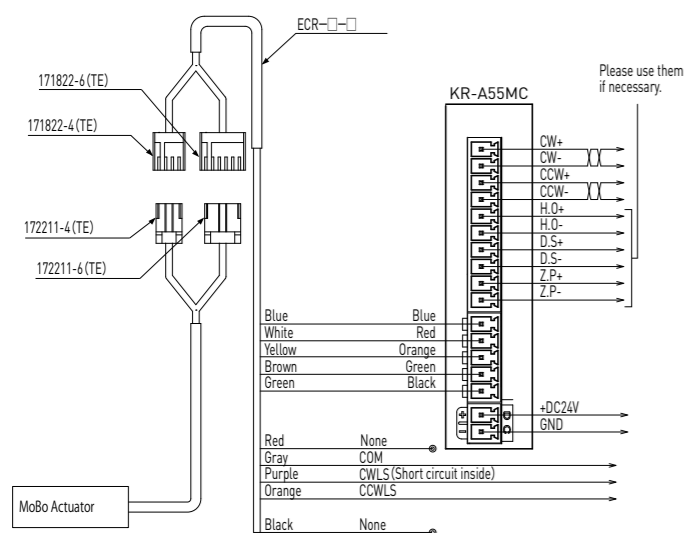

【HIROSE connector】

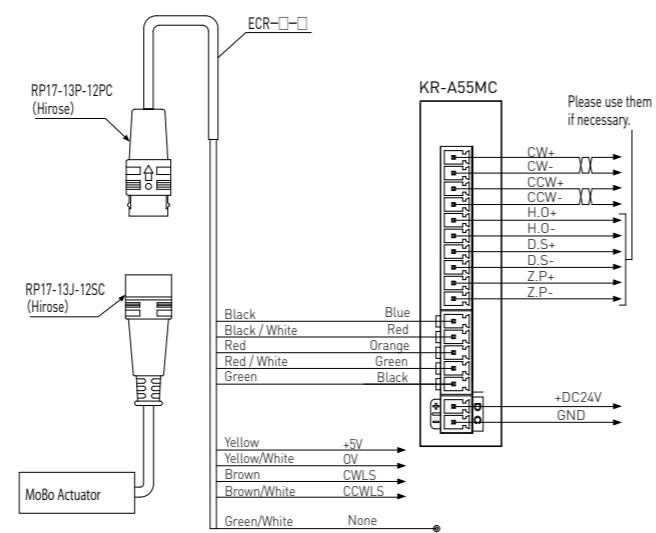

● Precaution of handling and operating

【Precaution for safety】

- 1) Before using these products, please read instruction manuals and follow the precautions below.
- 2) Do not hit or drop the Shaft, do not apply Axial or Radial load exceeding specifications, it may cause malfunction.
- 3) Before using, please check that the product has no defect, and product is the same as your order.
- 4) Do not disassemble each component, dust may get inside the product. It may deteriorate accuracy.
- 5) Please prevent contamination from dust or swarf. Dust or swarf may cause damage to Ball Screw/Lead Screw, which lead to deteriorating the function.
- 6) Single axis Actuator should be checked the lubricant condition every 2 to 3 months. If Grease is contaminated, remove old Grease and replace with new one. Grease should be the same as the original Grease, which is described in dimension table.
- 7) Do not use Single axis Actuator exceeding our specifications in Load or Speed.
- 8) Do not use Single axis Actuator beyond the Maximum Acceleration.
- 9) Do not hold the Motor leads and Sensor leads, this may result in damage to the device or injury. The Motor lead wire should be fixed securely.
- 10) Keep away from Magnetic memory device.

【Precaution for safety】

- 1) If abnormal odor, noise, smoke overheating, or vibration occurs, stop operation immediately and turn the power off.
- 2) Do not use exceeding rated current.
- 3) The Motor may overheat depending on the load conditions or driver used. Make sure that the Motor surface temperature does not exceed 80°C when in use.
- 4) Do not bend, pull or pinch the Motor lead wire.
- 5) Do not touch moving parts during operation.
- 6) Please switch off the Driver, when inspection or maintenance.

【Operating environment】

- 1) Operating environment should be 0~40°C in temperature and 20~80%RH in humidity. Do not use these products under dew condensation, corrosive gas or inflammable gas environment.
- 2) Do not use these products under strong electric field, strong magnetic field.
- 3) Please prevent from swarf, oil mist, cutting fluid, Water/moisture, salt spray, organic solvent and other contamination.
- 4) Single axis Actuator cannot be used under the vibration, impact, vacuum, and other special environment.