

Ball Screw Linear Actuators

- This is a Ball Screw type Compact Electric Linear Actuators with Stepping Motor.
- 3 types of Linear Actuators, Captive, Non-captive, & External, are provided for customer's usage.
- KSS is only one manufacturer who has all 3-types of Linear Actuators.
- Wide variety of selection of Motor & Ball Screw are available.

● Features

- High accuracy & compactness are achieved due to direct drive structure.
- Compact design, to reduce the number of components, to save the labor cost are possible.
- High efficiency, long life & high accuracy can be achieved compared to lead screw type.
- Pick one models that fits your application or specifications among variety of combination, Motor size, Ball screw type & screw lead.

● Variation and Structure

External type

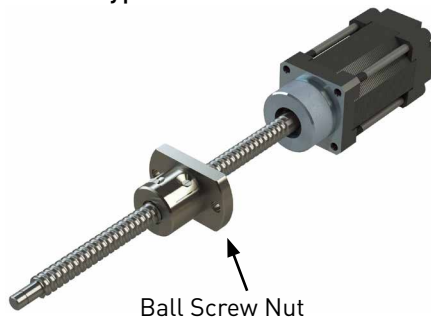

Stepping Motor is directly mounted onto Ball Screw shaft, so that Coupling is not required in this type of Actuator.

Captive type

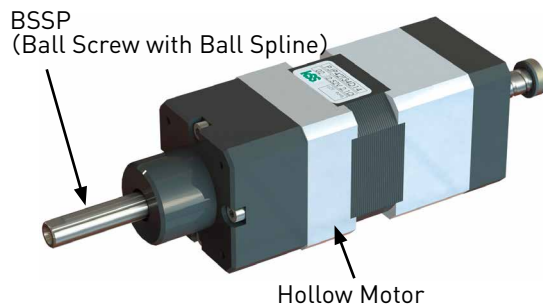

Ball Screw with Ball Spline (BSSP) is built in the Hollow Motor. Ball Spline Nut plays a role of anti-rotating device and slide guide. No need to set up anti-rotating design outside the Actuators.

Non-Captive type

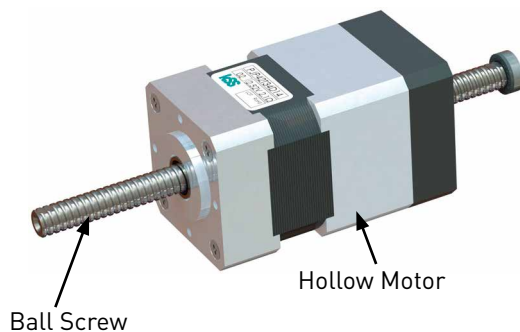

This is the simple design Linear Actuator with Ball Screw built in Hollow Motor. Anti-rotating device should be set up outside Actuators when usage.

Linear Actuator Captive, Non-Captive Type

Compact type Electric Cylinder with 2-phase Hollow Stepping Motor integrated with Ball Screw or Ball Screw with Ball Spline (BSSP).

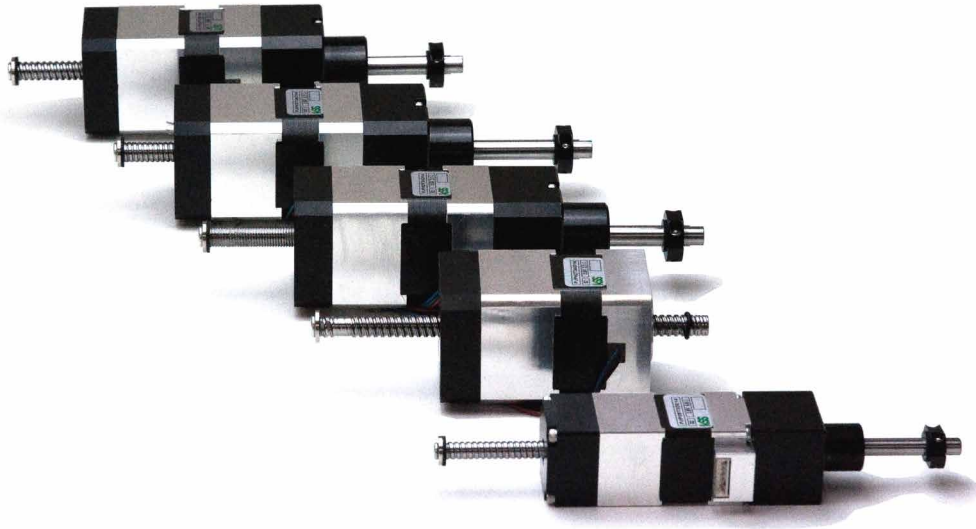

● Features

- The new Cylinder type Actuator comes with 2 Motor sizes, NEMA 11 & NEMA 17. Captive type with anti-rotating device or Non-Captive type without anti-rotating device can be selected in each Motor size as standard.
- Variety of Drive Screw, Shaft diameter & Lead combination allows wider selection of Accuracy and Thrust Force.

● Types

Captive Type

KSS miniature Ball Screw with Ball Spline(BSSP) is used for an anti-rotating device.

Non-Captive Type

Simple combination of the Hollow Motor and the Ball Screw contributes to lightweight and compact body.

● Variation

Unit : mm

	Drive Screw	Notation	NEMA 11 (□28)		NEMA 17 (□42)	
			Lead	Travel	Lead	Travel
Captive type	Precision Ball Screw	G	1,2	40	2,5	50
Non-Captive type	Precision Ball Screw	G	1,2	40,80	2,5	50,100
	Rolled Ball Screw	R	1,2	40,80	2,5	50,100

Note) If the Lead other than the above is required, please ask KSS representative.

Internal Structure

Captive type

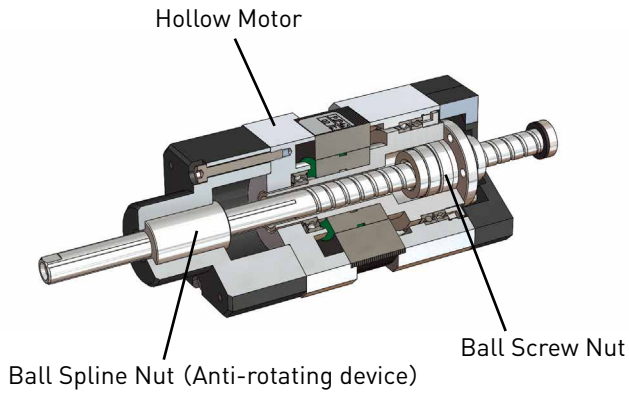

Ball Spline Nut in BSSP plays a role of anti-rotating device. No need to set up anti-rotating design outside the Actuator. Our unique BSSP enable a compact and slim body by using Ball Spline Nut as an anti-rotating device.

Non-Captive type

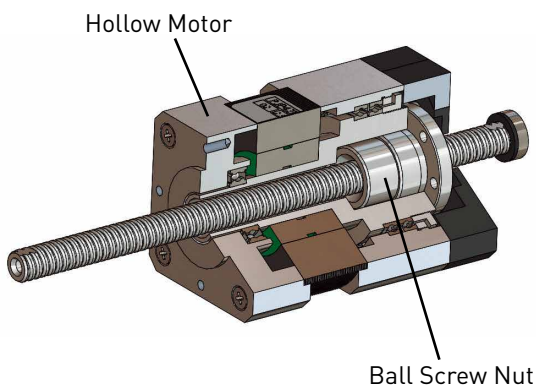

Simple design of Screw Shaft in Hollow Motor. External anti-rotating device should be set up when usage.

Model number notation

DDA **AR** **42** **-** **G** **05** **050** **N** **XXX**

① ② ③ ④ ⑤ ⑥ ⑦ ⑧

- ① Series No.
DDA : Direct Drive Actuator Series
- ② Cylinder type
AR : Captive type
CL : Non-Captive type
- ③ Motor size
42 : NEMA 17 Stepping Motor
28 : NEMA 11 Stepping Motor
- ④ Lead Screw / Ball Screw type
G : Precision Ball Screw
R : Rolled Ball Screw
- ⑤ Lead / Pitch (mm) : 05 means 5mm
- ⑥ Travel (mm) : 050 means 50mm
- ⑦ Connector type
N : No connector (Bare)
E : EI connector (TE Connectivity)
- ⑧ Extra notation

● Specifications

[Captive type]

Model	DDAAR28-G01 040	DDAAR28-G02 040	DDAAR42-G02 050	DDAAR42-G05 050
Motor size	NEMA 11 □28		NEMA 17 □42	
Travel	40mm		50mm	
Drive Screw	Precision Ball Screw with Ball Spline			
Screw lead	1mm	2mm	2mm	5mm
Resolution	0.005mm	0.01mm	0.01mm	0.025mm
Repeatability	±0.005mm			
Lost motion	0.010mm			
Thrust force	50N	25N	80N	30N
Permissible speed	20mm/sec	40mm/sec	40mm/sec	100mm/sec
Acceleration & Deceleration time	Min. 0.2 sec			
Operating Temperature	0~40°C (No Condensation)			
Lubrication	KSS original Grease MSG No.2			
Mass	270g		660g	

[Non-Captive type]

Model	DDACL28-G01 040 / 080	DDACL28-G02 040 / 080	DDACL28-R01 040 / 080	DDACL28-R02 040 / 080	DDACL42-G02 050 / 100	DDACL42-G05 050 / 100	DDACL42-R02 050 / 100	DDACL42-R05 050 / 100
Motor size	NEMA 11 □28				NEMA 17 □42			
Travel	40mm / 80mm				50mm / 100mm			
Drive Screw	Precision Ball Screw		Rolled Ball Screw		Precision Ball Screw		Rolled Ball Screw	
Screw lead	1mm	2mm	1mm	2mm	2mm	5mm	2mm	5mm
Resolution	0.005mm	0.010mm	0.005mm	0.010mm	0.010mm	0.025mm	0.010mm	0.025mm
Repeatability	±0.005mm		±0.010mm		±0.005mm		±0.010mm	
Lost motion	0.010mm		0.020mm		0.010mm		0.020mm	
Thrust force	50N	25N	50N	25N	80N	30N	80N	30N
Permissible speed	20mm/sec	40mm/sec	20mm/sec	40mm/sec	40mm/sec	100mm/sec	40mm/sec	100mm/sec
Acceleration & Deceleration time	Min. 0.2 sec							
Operating Temperature	0~40°C (No Condensation)							
Lubrication	KSS original Grease MSG No.2							
Mass	St 40:230g St 80:240g	St 40:230g St 80:240g	St 40:230g St 80:240g	St 40:230g St 80:240g	St 50:530g St 100:550g	St 50:530g St 100:550g	St 50:530g St 100:550g	St 50:530g St 100:550g

● Recommended Driver

KSS provides recommended Stepping Motor Driver as an option for Linear Actuator in order to make it easy to use.

KR-A5CC

This Driver is for 5-phase Stepping Motor operated by DC24V power supply. It has automatic current reduction circuits. You can choose full-step or half step function.



KR-A55MC

Micro-Step Driver for 5-phase Stepping Motor with DC24V power supply. 16 step angle types can be set up to 250 divisions.



KR-A535M

Micro-Step Driver for 5-phase Stepping Motor, which can be used with AC100~220V power supply. 16 step angle types can be set up to 250 divisions.



SD4015B3

This is recommended for Motor model 08E2004 of DMB series. It has automatic current down function and Micro-step function with 8-step angle.



SD4030B3

This is recommended for 2 phase stepping Motor Linear Actuator.
(Motor model: Other than 08E2004)
It has automatic current down function and Micro-step function with 8-step angle.



● Extension Cable

Extension Cable between Linear Actuator Captive type or Non-Captive type, and KSS recommended Stepping Motor Driver.

Please designate Cable length and Connector type in accordance with the example below.

Please note that one side of Extension Cable is cut end only (no connector).

EC R — 2 — E(6)
 ① ② ③ ④

① Extension Cable

② Cable type

R : Robot cable type

③ Cable length (m)

④ Connector type at both end

N : No connector (Cut only)

E(6) : El connector 6-pins

E(4) : El connector 4-pins

E(6+4) : El connector 6+4-pins

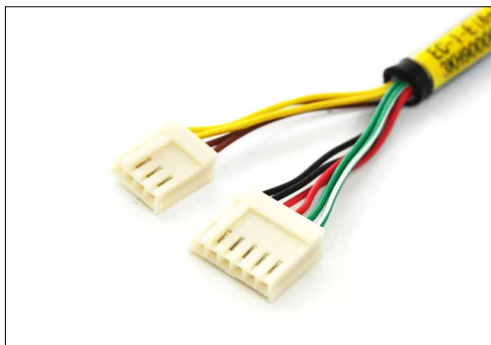

E(6+4) : El connector 6+4-pins
(TE Connectivity)

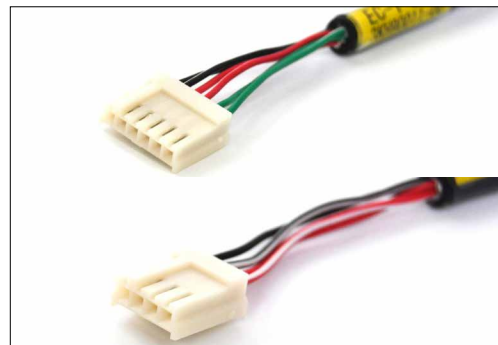

E(6) : El connector 6-pins
E(4) : El connector 4-pins
(TE Connectivity)

●Linear Actuator Connection diagram

Describe the connection diagram between the KSS Linear Actuator and the recommended driver.
Please check the combination of the Linear Actuator and the driver, then wire according to diagrams as shown below.

Type	Series	Recommended Driver	Output current	Connection diagram
External	DMB (Motor Model : 08E2004)	SD4015B3	0.25 ~ 1.5A/phase	Fig. P-3
	DMB (Motor Model : Other than 08E2004)	SD4030B3	0.5 ~ 3A/phase	Fig. P-4
	2TMB	SD4030B3	0.5 ~ 3A/phase	Fig.P-5
	MB / TMB	KR-A5CC	0.1 ~ 0.9A/phase	Fig. P-6
		KR-A55MC	0.4 ~ 1.4A/phase	Fig. P-7
		KR-A535M	0.4 ~ 1.4A/phase	Fig. P-8
Captive Non-Captive	DDAAR / DDACL	SD4030B3	0.5 ~ 3A/phase	Fig. P-9

External type

■Applicable Product series

DMB series (Motor model : 08E2004)

■Recommended Driver

SD4015B3 : 2-phase Microstep Driver

**Output current : 0.25~1.5A/Phase

※Caution

- The factory setting of SD4015B3 is 1A.
- Please be sure to perform a current set up of Driver based on Motor Rated current before use.
- For the details about current setup, please download the manual from KSS web site.

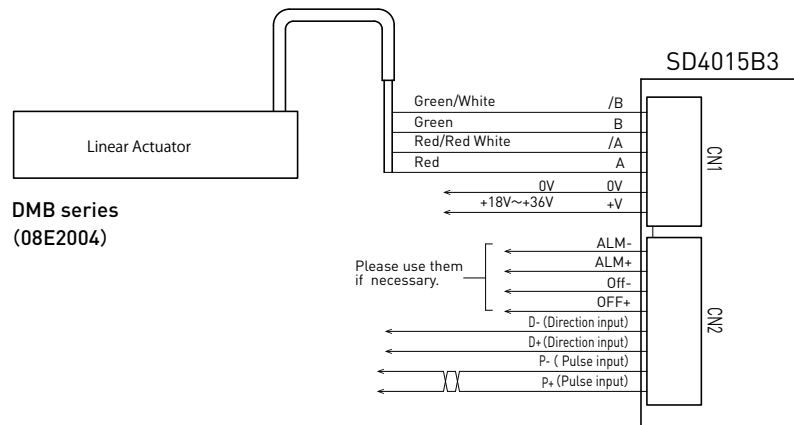

【Fig.P-3】

■Applicable Product series

DMB series (Motor model : Other than 08E2004)

■Recommended Driver

SD4030B3 : 2-phase Microstep Driver

**Output current : 0.5~3A/Phase

※Caution

- The factory setting of SD4030B3 is 2A.
- Please be sure to perform a current set up of Driver based on Motor Rated current before use.
- For the details about current setup, please download the manual from KSS web site.

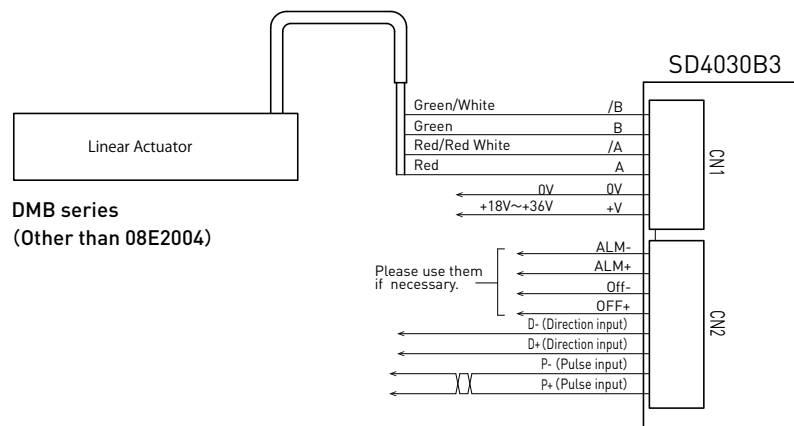

【Fig.P-4】

■ Applicable Product series

2TMB series

■ Recommended Driver

SD4030B3 : 2-phase Microstep Driver

**Output current : 0.5~3A/Phase

※ Caution

- The factory setting of SD4030B3 is 2A.
- Please be sure to perform a current set up of Driver based on Motor Rated current before use.
- For the details about current setup, please download the manual from KSS web site.

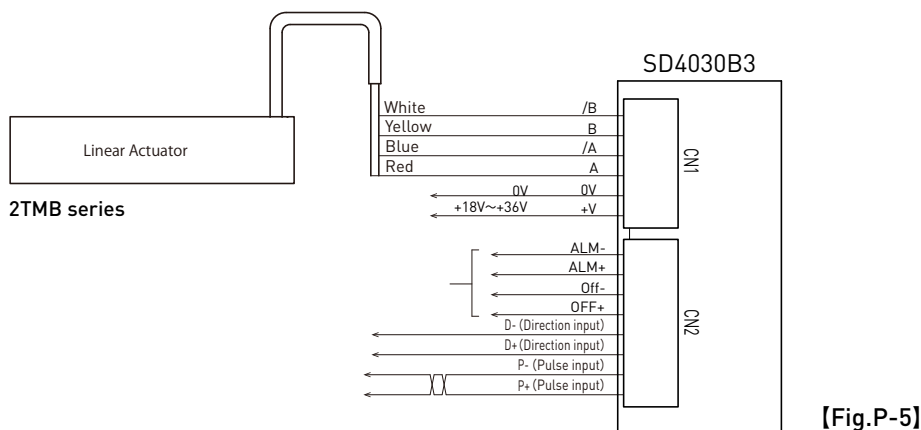

■ Applicable Product series

MB series

TMB series

■ Recommended Driver

KR-A5CC : 5-phase Stepping Motor Driver

**Output current : 0.1~0.9A/Phase

※ Caution

- The factory setting of KR-A5CC is 0.35A.
- Please be sure to perform a current set up of Driver based on Motor Rated current before use.

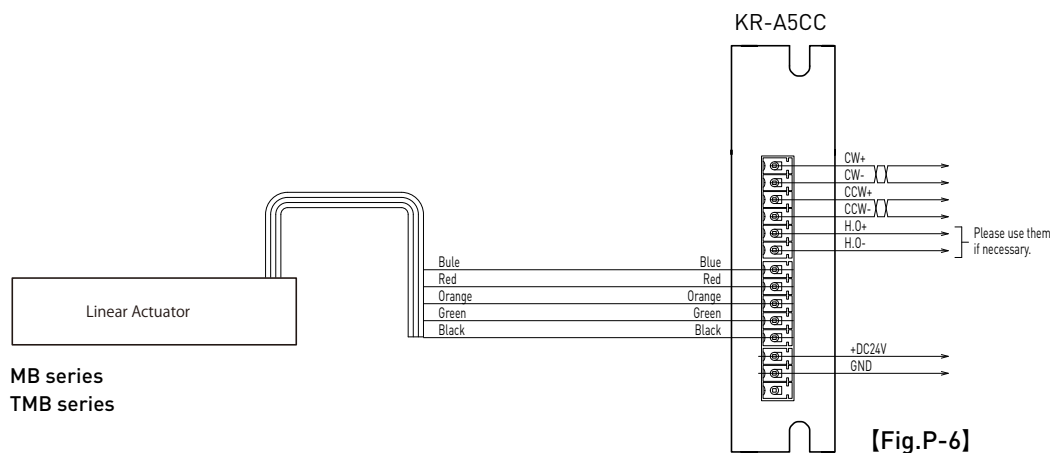

■ Applicable Product series

- MB series
- TMB series

■ Recommended Driver

KR-A55MC : 5-phase Microstep Driver

**Output current : 0.4~1.4A/Phase

※ Caution

- The factory setting of KR-A55MC is 0.75A
- Please be sure to perform a current set up of Driver based on Motor Rated current before use.

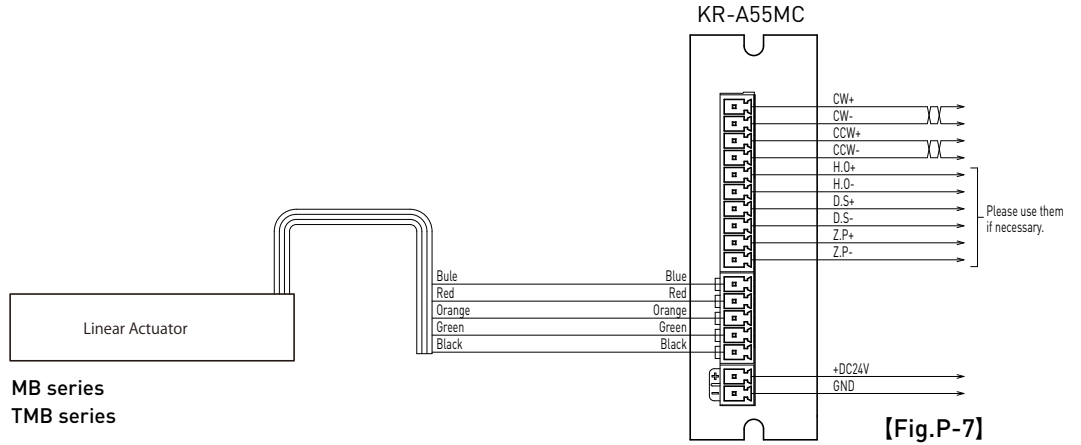

■ Applicable Product series

- MB series
- TMB series

■ Recommended Driver

KR-A535M : 5-phase Microstep Driver

**Output current : 0.4~1.4A/Phase

※ Caution

- The factory setting of KR-A535M is 0.75A
- Please be sure to perform a current set up of Driver based on Motor Rated current before use.

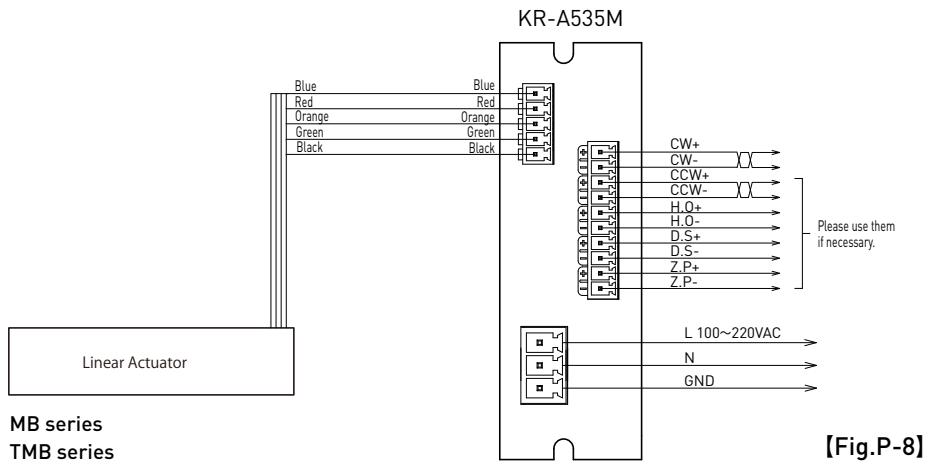

Captive, Non-Captive type

■Applicable Product series

Captive type, Non-Captive type

■Recommended Driver

SD4030B3 : 2-phase Microstep Driver

**Output current : 0.5~3A/Phase

※Caution

- The factory setting of SD4030B3 is 2A.
- Please be sure to perform a current set up of Driver based on Motor Rated current before use.
- For the details about current setup, please download the manual from KSS web site.

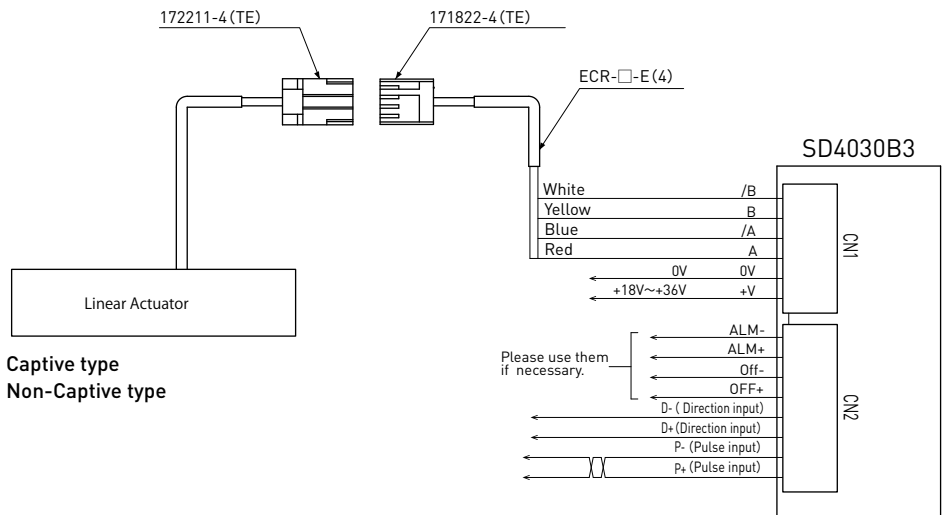

[Fig.P-9]

Motor cable 172211-4 (male)

1	Stepping Motor /B (Blue)
2	Stepping Motor B (Red)
3	Stepping Motor /A (Green)
4	Stepping Motor A (Black)

Motor Extension cable 171822-4 (female)

4	3	2	1	1	Stepping Motor /B (Blue)
				2	Stepping Motor B (White)
				3	Stepping Motor /A (Yellow)
				4	Stepping Motor A (Brown)

● Precaution of handling and operating

★ Precaution for operating

1. Before use, please read instruction manuals and follow the precautions below.
The instruction manuals are available on KSS web site.
2. Do not hit or drop the Shaft, do not apply Axial load exceeding specifications or Radial load, it may cause malfunction.
3. Before use, please check that the product has no defect, and product is the same as your order.
4. Do not disassemble each component, dust may get inside the product. It may deteriorate accuracy.
5. Please prevent contamination from dust or swarf. Dust or swarf may cause damage to Ball Screw, which lead to deteriorating the function.
6. Motor is not designed to resist water oil. Item cannot be used in direct exposure of water or oil, or environment such as oil bath.
7. Lubrication is required under the Ball Screw operation. Lubricant condition should be checked every 2 to 3 months. If Grease is contaminated, remove old Grease and replace with new one.
8. Do not use the Actuator exceeding our specifications in Load or Speed.
9. Care must be taken not to apply Radial load or Moment load directly on Ball Screw.
This will lead to shorten the Ball Screw life remarkably. In addition, misalignment between Ball Screw and other components will lead to deterioration of function, such as accuracy, life and so on.
10. Allowing Ball Screw Nut to over-run may result in malfunctioning due to Balls escaping, damage to recirculation parts, and indentation on the raceways. Continued use in this state will lead to rapid wear and damage to recirculation parts. Therefore Ball Screw Nut must never be allowed to over-run.
If over-running occurs, contact KSS for an inspection with charge.
11. Acceleration & Deceleration rate should be followed by recommended number described in each series. Do not use Linear Actuator under our recommended Acceleration & Deceleration Rate.

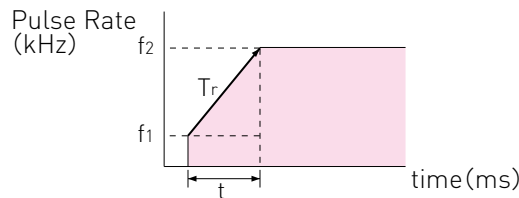

$$T_r = \frac{t}{f_2 - f_1}$$

T_r : Acceleration & Deceleration Rate (ms/kHz)
 t : Acceleration & Deceleration time (ms)
 f_1, f_2 : Pulse Rate (kHz)

12. Do not hold the Motor lead wire. Motor lead wire is for fixation, do not use the Motor lead wire as movabilities.
13. Keep away from Magnetic memory device.
14. The Motor torque and speed characteristics may vary from the specifications, depending on the load conditions or Driver used.
15. The Motor has a resonant point within the specifications. Please avoid the resonant point when in use.

★Precaution for safety

1. If abnormal odor, noise, smoke, overheating, or vibration occurs, stop operation immediately and turn the power off.
2. Do not use the Actuator exceeding rated current.
3. Check and confirm the polarity of the power supply in prior to activate the Motor.
4. The Motor may overheat depending on the load condition or Driver used.
Make sure that the Motor surface temperature does not exceed 80°C when in use.
5. Check the wire connection type, Drive system, and phase sequence.
Inappropriate connection leads to malfunction.
6. A ground connection must be used.
7. Do not bend, pull or pinch the Motor lead wire.
8. Do not touch moving parts during operation.
9. Disconnect from the Controller before performing dielectric withstanding voltage test of the Motor or megger test.
10. Please switch off the Driver, when inspection or maintenance.

★Operating environment

1. Operating environment should be 0~40°C in temperature and 20~80%RH in humidity.
Do not use the Actuator under dew condensation, corrosive gas or inflammable gas environment.
2. Do not use the Actuator under strong electric field, strong magnetic field.
3. Please prevent from swarf, oil mist, cutting fluid, water/moisture, salt spray, organic solvent and other contamination.
4. The Actuator cannot be used under the vibration, impact, vacuum, and other special environment.

★Precaution for External type

- ※Since External type is the product which integrated the Motor Shaft and the Screw Shaft, repair is not possible, if either Motor or Ball Screw is damaged.

Anti-rotating device built-in model

DDAAR □28 / NEMA 11

Shaft dia. $\phi 6$

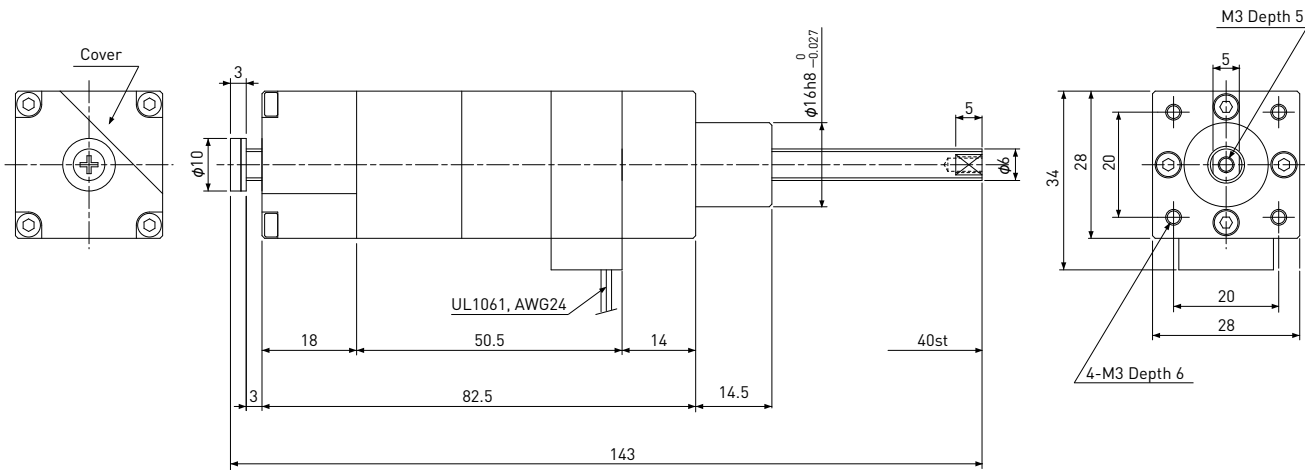

Motor lead wire

A	Black
\bar{A}	Green
B	Red
\bar{B}	Blue

UL1061, AWG24(310mm)

Recommended Drivers

SD4030B3

Note) Refer to page P164 for connection diagram of recommended Drivers.

Specifications		
	DDAAR28-G01 040	DDAAR28-G02 040
Drive Screw type	Precision Ball Screw	
Screw lead	1mm	2mm
Travel	40mm	
Repeatability	$\pm 0.005\text{mm}$	
Lost Motion	0.010mm	
Permissible Speed	20mm/sec	40mm/sec
Acceleration & deceleration time	Min. 0.2sec	
Thrust Force	50N	25N
Mass	270g	

Motor Specifications	
Basic step angle	1.8°
Driving method	2-phase Bi-polar
Rated Voltage	DC 3.8 V
Rated current	0.67 A/phase
Winding resistance	5.6Ω
Winding inductance	5.3mH
Insulation Class	Class B (130°C)
Operating Temperature	0~40°C (No Condensation)

Precautions

- Radial load can not be applied on Captive type. For more detail, please see page S105.
- Specifications above are reference value measured in vertical position at virgin condition.
- Sensor is not built in this standard design. Please ask KSS if necessary

Anti-rotating device built-in model

DDAAR □42 / NEMA 17Shaft dia. $\phi 8$

Linear Actuator Captive, Non-Captive type

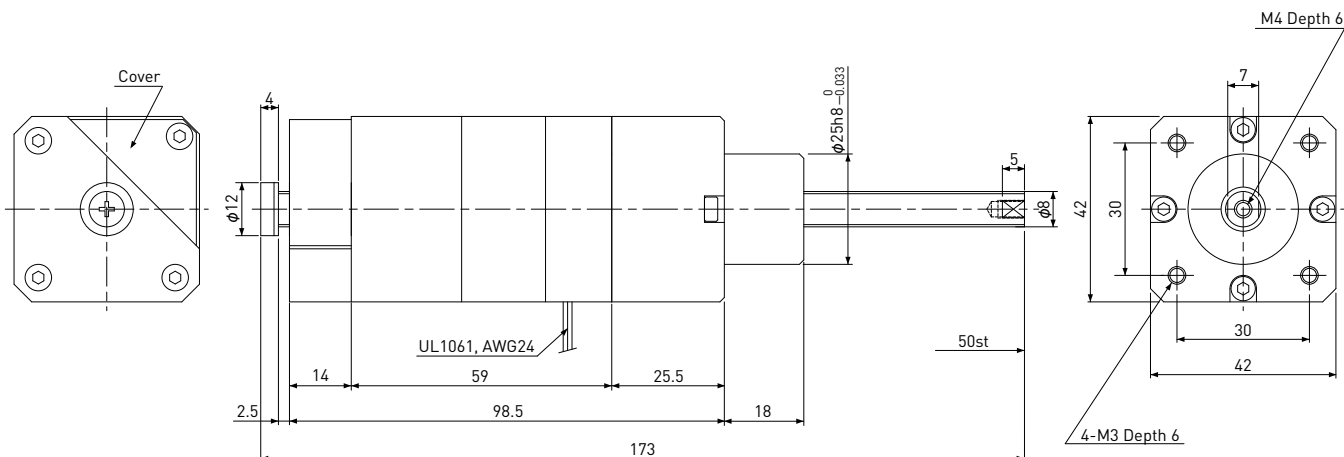

Motor lead wire

A	Black
\bar{A}	Green
B	Red
\bar{B}	Blue

UL1061, AWG24 (310mm)

Recommended Drivers

SD4030B3

Note) Refer to page P164 for connection diagram of recommended Drivers.

	Specifications	
	DDAAR42-G02 050	DDAAR42-G05 050
Drive Screw type	Precision Ball Screw	
Screw lead	2mm	5mm
Travel	50mm	
Repeatability	$\pm 0.005\text{mm}$	
Lost Motion	0.010mm	
Permissible Speed	40mm/sec	100mm/sec
Acceleration & deceleration time	Min. 0.2sec	
Thrust Force	80N	30N
Mass	660g	

Motor Specifications	
Basic step angle	1.8°
Driving method	2-phase Bi-polar
Rated Voltage	DC 2.5 V
Rated current	1.2 A/phase
Winding resistance	2.1 Ω
Winding inductance	4.0mH
Insulation Class	Class B (130°C)
Operating Temperature	0~40°C (No Condensation)

Precautions

- Radial load can not be applied on Captive type.
For more detail, please see page S105.
- Specifications above are reference value measured in vertical position at virgin condition.
- Sensor is not built in this standard design. Please ask KSS if necessary