



Goniometer Cross Roller Guide



JRV



Goniometer Cross Roller Guide

<Fig. 1> Structure of goniometer cross roller guide model JRV

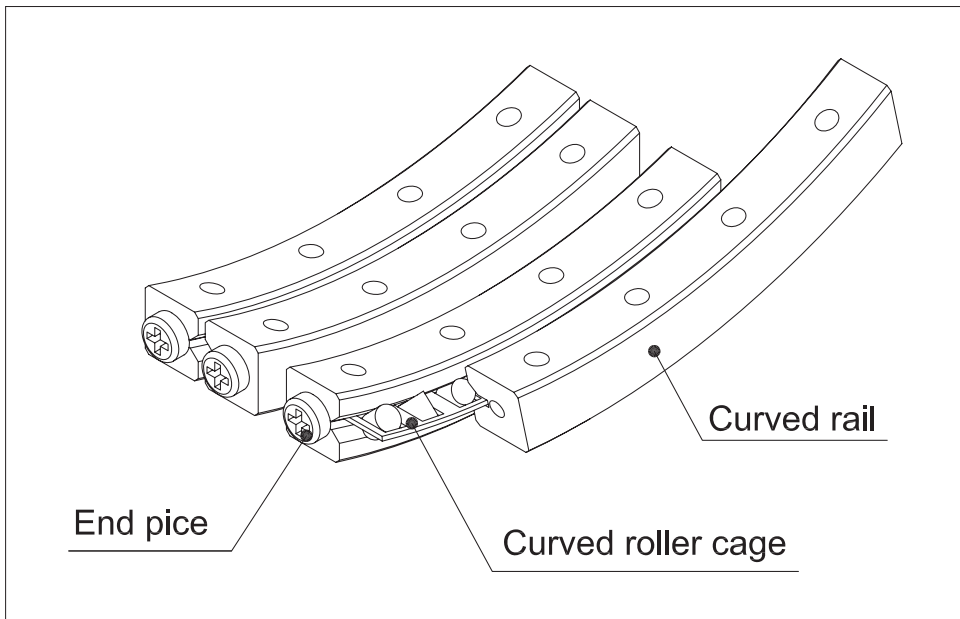

■ Structure

BSQ's goniometer cross roller guide JRV is a non re-circulating cross roller bearing providing low friction radius movement. The JRV is ideal for applications where sweeping movement or precise angular positioning is required without changing rotation center, such as in optical equipment and measuring devices.

■ Features

BSQ goniometer cross roller guide JRV consists of precision ground, hardened, curved, “V” shape rails, and curved roller cages in which cross rollers are fitted. Precision cross roller design minimizes frictional resistance providing for stabilized curved movement with extremely low friction.

■ Low friction, precise movement

Precision grinding and curved roller cage allow for low elements friction with negligible difference between statically and dynamic friction. This feature provides for precise curved movement and fine feed.

■ High rigidity, high load

Greater surface contact area from cross roller design and provides hardened ground rails allow for less elastic deformation and provides high rigidity and load capacity.

■ Easy of installation

BSQ's unique curved roller cage retains precision cross roller easing in the installation process. BSQ goniometer crossed roller guide consists of four rails, two cages, and eight and pieces as one set.

■ Low noise

The non re-circulating design and non-contact between rollers for extremely low noise.

■ Accuracy standards

Accuracy for overall length is measured as shown in <Fig. 2>

<Fig. 2> Moment rigidity

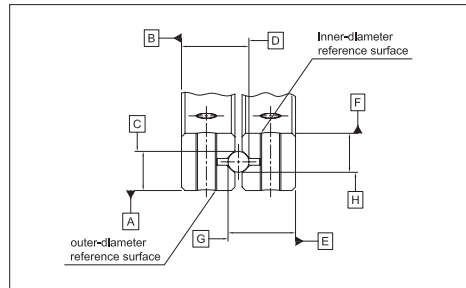

<Table. 1> Accuracy

Model no.	Accuracy
JRV 2040-50-7Z	10
JRV 2060-60-12Z	
JRV 3050-50-8Z	
JRV 3050-68-7Z	
JRV 3060-50-10Z	
JRV 3060-68-10Z	
JRV 3060-100-8Z	
JRV 3070-70-12Z	
JRV 3070-90-11Z	
JRV 3070-96-10Z	
JRV 3070-110-10Z	
JRV 3070-122-10Z	
JRV 3100-160-14Z	

■ Rated life span L

The life of a goniometer crossed roller guide is obtained using the following equations.

$$L = \frac{90}{\theta} \times \frac{f_t}{f_w} \times \frac{C}{P}^{\frac{10}{3}}$$

- L : Rated life span (106 cycles)
- θ : Rotating angle (°)
- C : Basic dynamic load rating (kN)
- P_c : Applied load (kN)
- f_t : Temperature factor refer to <Fig. 3>
- f_w : Load factor refer to <Table. 2>

<Fig. 3> Temperature factor (f_t)

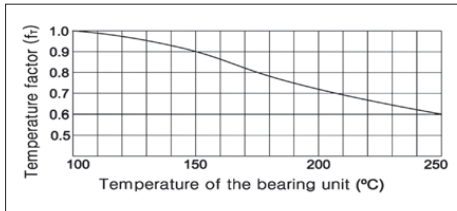

Note) In case that environment temperature is over 100°C, contact BSQ

■ f_w : Load factor

Shuffling machines is likely to be affected by vibration or impact during drive, while driving high speed, particularly, it is a lot more difficult to calculate each value precisely. Therefore, if the load applied to the curved linear motion system cannot be calculated or the impact of speed vibration is large, the load factor in the table below should be divided into the basic load rating(C) and (C₀).

<Table. 2> Load factor (f_w)

Vibration • Impact	Velocity (V)	f _w
No	More than 15m/min	1.0~1.5
Small	More than 60m/min	1.5~2.0
Large	More than 60m/min	2.0~3.5

■ Installation

■ Accuracy of Mounting Surface

To achieve sufficient performance of BSQ's goniometer crossed roller guide JRV, it is advised to finish installation surface in same or higher accuracy to that of JRV type.

<Fig. 4> Accuracy of installation surfaces

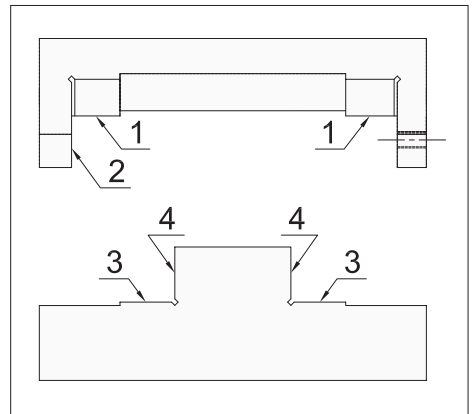

■ Installation procedure

- (1) Remove burr, flaw, and debris on curved installation surface of table and bed to keep clean from foreign material while installation work is conducted.
- (2) Stabilize rails shown as ①, ② and ③ by tightening torque as instructed. (Fig. 5 b)
- (3) Tighten rail shown as ④ temporarily. (Fig. 5 b)
- (4) Remove the end pieces from one end, insert curved roller cage slowly until it reaches middle position. (Fig. 5 c)
- (5) Replace the end pieces once fitted above.
- (6) Move the table to maximum stroke end to left and tight and adjust curved roller cage come to the center of the tail assembly.
- (7) Fit indicator to side of the table. (reference plane side) (Fig. 5 d)
- (8) Move the table to stroke end of one side and tighten adjust screw on curved roller cage lightly. (Fig. 5 e)
- (9) Move the table to stroke end of the opposite side and tighten adjust screw slightly. (Fig. 5 f)
- (10) Move the table to the center position and tighten adjust screw at center position slightly. (Fig. 5 g)
- (11) Repeat above procedures from (8) through (10) until no play is confirmed. Once no more play exist, oscillation of the indicator becomes stabilizes at minimum value, when the table is moved to left and right. Please take caution not to apply excessive preload.
- (12) Conduct final adjustment for preload. In the manner described on above procedures from (8) through (10), tighten adjust screw by torque wrench following the torque recommended in (Table. 3)
- (13) Finally, stabilize rail ④, which is fitted temporarily. Installation bolts for rail ④ should be tightened in same sequence as adjust screws.

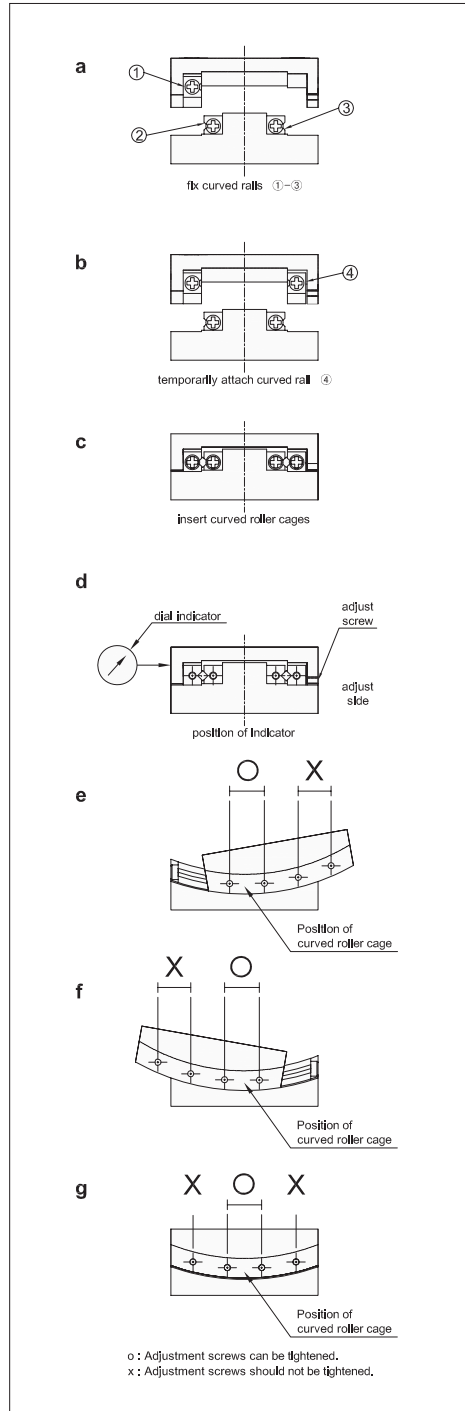

■ Rated life span L

■ Lubrication

BSQ's goniometer crossed roller guide JVR contains a lithium soap-based grease and can be used as delivered. As use continues of lubricate as required depending upon operating conditions.

■ Dust prevention

Depending upon the operating environment, dust and debris may be able to invade goniometer crossed roller guide and disrupt the ideal operating performance. Therefore it is advised to protect the gonio guide with covers or bellows if such a harsh environment exists.

■ Operating environment (temperature)

For goniometer crossed roller guide JRV, the recommended ambient working temperature is between -20°C and 100°C .

■ Adjustment

Install and adjust goniometer crossed roller guide carefully. When accuracy of installation surfaces and adjustment of preload are insufficient, cross roller gonio guide motion accuracy can be deteriorated and thus, can cause to skew movement and may reduce performance and life.

■ Cage creep

When the goniometer crossed roller guide is used in an application where high speed, vibration, or an unbalanced load is present, the cage would go out of position. To minimize cage creep, allow for extra stroke distance prevent from excess of preload.

■ Stopper

End pieces are fitted at both ends of cross roller gonio guide rail to prevent the cross roller gonio guide roller cage from existing out.

■ Careful handling

Rough handling will affect the precision performance of the gonio guide. Handle as a precision components.

■ Use as set

Goniometer crossed roller guide is supplied as a set of rail (4), roller cage (2), and stoppers (8), and should not be mixed with other sets.

■ Custom specification

BSQ accepts custom requests of goniometer crossed roller guide such as, length of rail, radius or rotation, radius stroke range, number of rollers fitted and so on. If custom goniometer crossed roller guide JRV are required, please contact BSQ for further assistance.

JRV

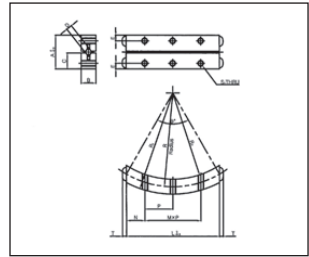
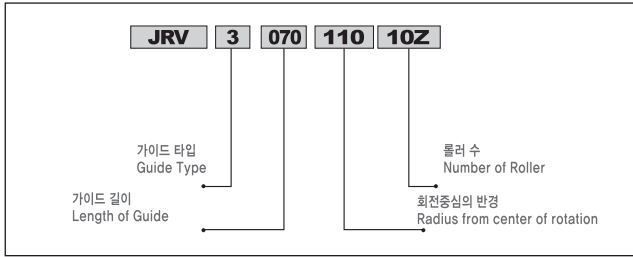
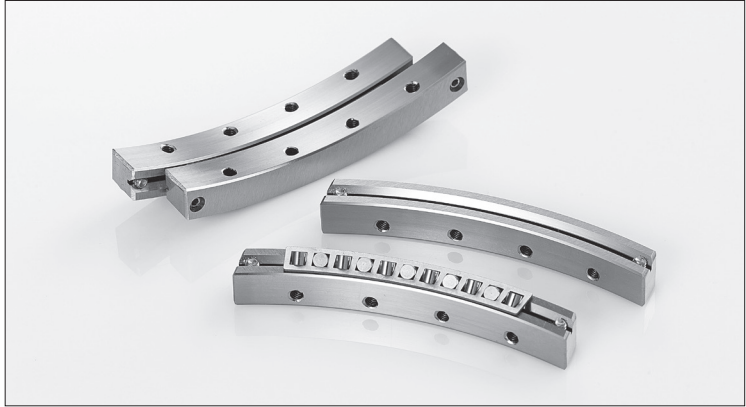

Specification Model	회전범위 Rotating Range	롤러외경 Roller Dia. D	롤러수 The Number of Rollers Z	주요 치수 Main Dimension												기본정격하중 Basic Load Rating		질량 Weight	
				L	R ₁	R	R ₂	A	B	C	M x P	N	E	S ₁	T	θ	C _N		C _{0N}
JRV 2040 - 50 7Z	±10°	2	7	40	50	53	47	15	6	7.25	2×12.5	7.5	2.5	M3	1.5	47.3°	802	813	49
JRV 2060 - 60 12Z			12	60	60	63	57				3×12.5	11.25				60.0°	1240	1530	75
JRV 3050 - 50 8Z	±10°	2	8	50	50	50	46	18	8	8.5	2×15	10	3	M3	2	60.0°	1870	2480	96
JRV 3050 - 68 7Z			7	50	68	72	64				2×15	10				43.0°	1720	2350	96
JRV 3060 - 50 10Z			10	60	50	54	46				2×15	15				74.0°	2530	3310	107
JRV 3060 - 68 10Z			10	60	68	72	64				2×15	15				52.0°	2530	3310	107
JRV 3060 - 100 8Z			8	60	100	104	96				2×15	15				35.0°	2040	2560	107
JRV 3070 - 60 12Z			12	70	70	74	66				3×15	12.5				60.0°	2900	3840	138
JRV 3070 - 90 11Z			11	70	90	94	86				3×15	12.5				45.8°	2630	3510	138
JRV 3070 - 96 10Z			10	70	96	100	92				3×15	12.5				43.0°	2420	3200	138
JRV 3070 - 110 10Z			10	70	110	114	106				3×15	12.5				37.1°	2630	3510	138
JRV 3070 - 122 10Z			10	70	122	126	118				3×15	12.5				33.0°	2420	3200	138
JRV 3100 - 160 14Z			14	100	160	164	156				3×15	12.5				33.4°	3380	4920	193